

SPiiPlusCM_{HP/BA}

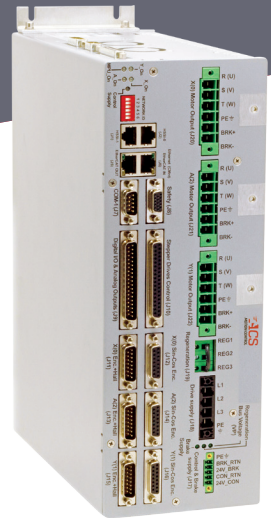

32 Axis EtherCAT® Master Control Module with Three Built-in Drives

- Up to 32 axes and thousands of I/O
- Open Architecture – Command ACS and third party EtherCAT drives and I/O
- Plug-in replacement for the series of SPiiPlusCM Control Modules
- Two versions: Economical (ba) and High Performance (hp)
- Analog I/O: 8/2
- Optional built-in 4-axis Pulse/Dir interface and Laser control
- Three built-in drives
 - › Up to 265Vac, 15A continuous and 30A peak current
 - › 4 encoders
 - › 20kHz sampling and update rate of all control loops
- Digital I/O
 - › 8/8 general purpose inputs / outputs
 - › 4 Registration Mark inputs, 2/8 PEG outputs (Pulse/States)
 - › 3 motor brake outputs 24V/1A

The SPiiPlusCM_{HP/BA} is a state of the art series of EtherCAT motion controllers with three built-in universal drives. It addresses the needs of modern machinery for both economical and for high performance, scalable and distributed control for motion centric applications. Its open architecture operates in conjunction with ACS' line of EtherCAT servo and step motor drives and I/Os modules, as well as with any certified EtherCAT module that complies with CAN over EtherCAT (CoE) protocol, providing a comprehensive and cost effective control solution for demanding machinery.

The SPiiPlusCM_{HP/BA} controls and generates the motion profile for up to 32 axes.

The SPiiPlusCM_{HP} addresses high accuracy demanding applications, while the SPiiPlusCM_{BA} econo version addresses more price sensitive applications. The SPiiPlusCM_{HP/BA} are complemented by the SPiiPlusNT suite of software tools with built-in simulator that minimizes development effort and time to market. It provides extraordinarily easy setup, fast host and embedded application development, and quick diagnostics, reducing efforts and costs. The built-in drives are offered with three current levels: 5/10A, 10/20A and 15/30A (cont./peak).

The modules are powered by a single or three-phase AC of up to 265Vac (rectified internally to generate a Vac x 1.4 motor voltage) and by a separate 24Vdc control supply that keeps all low voltage signals alive during emergency conditions.

It supports a wide range of position feedback devices: incremental digital, analog Sin-Cos, and absolute encoders.

The modules are optionally available with built-in additional 4-axis control of drives with Pulse/Dir (P/D option) and Laser control interface (LC1 option).

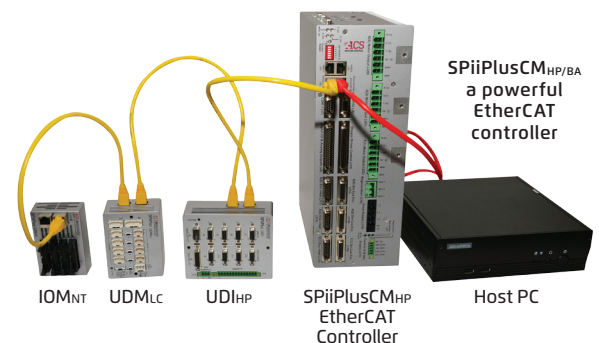

CE, UL (Pending)

EtherCAT® is registered trademark and patented technology, licensed by Beckhoff Automation GmbH, Germany

Contact us: sales@acsmotioncontrol.com | www.acsmotioncontrol.com

**In-Position
Technologies**
ACS
MOTION CONTROL

Specifications

Product (xx - BA or HP) (y - number of axes)	CMxxxA...	CMxxxB...	CMxxxC...
Number of built-in drives	1,2,3		
Motor voltage AC input [Vac]	85 - 265, single and 3 phase	130 - 265, single and 3 phase	
Control voltage input [Vdc]	24±10%		
Phase current Cont./Peak Sine amplitude [A]	5 / 10	10/20	15/30
Phase current Cont./Peak RMS [A]	3.6 / 7.1	7/14	10.6/21.2
Peak current time [sec]	1		
Max. output voltage [Vdc]	(Vac in) x1.41 x 97%		
Max. RMS input current 1-phase supply [A] 3-phase supply[A]	18 13	18	24 24
Min. load Inductance, at max. motor voltage [mH]	1		
Max. Heat dissipation per axis [W]	30	48	79
Weight [gram]	5750		
Dimensions [mm³]	324x249x120		
Standards	CE, UL (Pending)		

Example: CM_{BA}3B24E2NA1AWNANY

Field	1	2	3	4	5	6	7	8	9	10	11	12	13	14	15	16	17	
PN	CM	ba	3	B	2	4	E	2	N	A	1	A	W	N	A	N	Y	Y

Servo

A standard comprehensive set of powerful algorithms to enhance accuracy, move & settle time, smooth velocity, stability and robustness.

- Advanced PIV cascaded structure
- Loop shaping filters
- Gain Scheduling
- Gantry MIMO control
- Dual feedback / loop control
- Disturbance rejection control

Optional ServoBoost™ algorithm that provides better, more consistent servo performance, insensitive to noise and large changes in the system (HP version only).

Drives

Type: digital current control with field oriented control and space vector modulation.

Current ripple frequency: 40 kHz Current loop sampling rate: 20 kHz

Programmable Current loop bandwidth: up to 5 kHz

Commutation type: sinusoidal. Initiation with and without hall sensors

Switching method: advanced unipolar PWM

Protection: Over voltage, Phase-to-phase short circuit, Short to ground, Over current, Over temperature, motor over temperature

Current sensing: CM_{BA}: 12b ADC, CM_{HP}: 16b ADC

Power Supplies

The module is fed by three power sources.

A motor AC supply, a 24Vdc control supply and 24Vdc motor brake supply.

During emergency conditions there is no need to remove the 24Vdc control supply.

Motor Supply

Range: 85 to 265Vac, for 15/30A (cont./Peak)

current model: 130 to 265Vac

(Optional - Low Voltage 17-85Vac or 24-120Vdc)

Control Supply

24Vdc ± 10%, 4A

Motor Brake Supply

24Vdc ± 20%, 3A

Motor Type

3 and 2 phase AC synchronous, DC brush and step motors

Feedback

Incremental Digital Encoder: Four, A&B, I; Clk/Dir, I RS-422. Max. rate: 50 million encoder counts/sec., Protection: Encoder error, not connected

Sin-Cos Analog Encoder (optional): Three. 1Vptp, differential

Multiplication factor: From x4, to- CM_{BA}-x4,096, CM_{HP}-x65,536

Maximum frequency: 250kHz

Automatic compensation of Offset, Phase and Amplitude

ADC used: CM_{BA}: 12b, CM_{HP}: 16b low S/N

Maximum acceleration: 10⁸ million sine periods/sec². Protection: Encoder error, not connected.

Hall inputs: Three sets of three per axis.

Single-ended, 5V, source, opto-isolated

Input current: <7mA

Absolute encoders (optional): EnDat2.1(Digital)/2.2,

Tamagawa Smart-Abs, Panasonic, BISS-A/B/C, SSI

5V feedback supply: Total current available for feedback devices: 1A

Pulse/Direction Interface (Optional)

Four pairs.

Type: RS-422. Up to 5 million pulse/sec.

Programmable pulse width

Range: 0.08 to 80 microseconds

Laser Interface (Optional)

Pulse differential output, RS422

Fault input, Opto-isolated, 2-terminal

Enable output, Opto-isolate, 2-terminal

Pulse frequency: 9Hz to 1.181Mhz

Pulse width: 6.67ns to 111ms

Duty cycle: 0 to 100%

Ordering Options

Ordering options	Field	Example	Values
Type	1	ba	ba-economical, hp-high performance
Number of built-in drives (85Vac-265Vac)	2	3	1,2,3
Current rating of built-in drives (cont/peak)	3	B	A- 5/10A, B- 10/20A, C- 15/30A
Sin-Cos encoder interface	4	2	0,1,2,3
Digital incremental encoders	5	4	4
Absolute encoders type	6	E	N- None, E- EnDAT 2.1(digital)/2.2, S- Smart Abs, P- Panasonic, B- BISS-A/B/C, I- SSI
Number of Absolute encoders interface	7	2	0,1,2,3
STO	8	N	N - No (currently not available)
Maximum number of axes	9	A	4 (included automatically FOC), 8, A-16, B- 32
3rd party EtherCAT servo drives	10	1	0 to 16 (0,1,2,3,...,9,A,B,C,D,E,F,G)
3rd party EtherCAT Step motor Drives)	11	A	0 to 16 (0,1,2,3,...,9,A,B,C,D,E,F,G)
ECAT 3rd party IO EtherCAT nodes	12	W	W- 32 (included automatically FOC), X- 64
G-Code	13	N	N- None, G- G-code
ServoBoost™ , number of axes supported (HP version only)	14	A	N- 0, A- 4, B- 8, C- 12, D- 16, E- 20, F- 24, G- 28, H- 32
Input shaping	15	N	Y- Yes, N- No
Pulse-Dir for 4 axes or LC1 option installed	16	Y	N- No, Y- P/D, L- LC1
Low Voltage operation (17-85Vac or 24-120Vdc)	17	Y	Y- Yes, N- No

Digital I/O

Safety Inputs: Left + right limit per axis, E-stop

General Purpose Inputs: 8 Single-ended, 5Vdc (±10%) or 24Vdc (±20%), opto-isolated, sink/source, Input current: 14mA

Registration MARK inputs: Four. RS422

Motor Brake Outputs: Three. 24V, 1A, ,opto-isolated. Powered by the 24V Brake Supply

General Purpose Outputs: Eight. Single-ended, 5Vdc (±10%) or 24Vdc (±20%), opto-isolated,

sink/source, Max. output current per output: 100mA, Max. total of 800 mA for all

Position Event Generator outputs (PEG):

Two PEG_Pulse and eight PEG_State, RS422

Can be used as GP outputs

HSSI channels: Two. RS422

Analog I/O

Inputs: Six ±10V, differential, 20kHz sampling rate.

The inputs can be used as feedback to the servo loops. Resolution: CM_{BA} - 12b, CM_{HP} - 16b Joystick

inputs: two single-end, ±10V, 12b resolution

Outputs: Two, single-end, ±10V, 10b resolution

Controller and EtherCAT Master

Number of axes: Up to 32.

MPU/EtherCAT Max. Cycle Rate: 2kHz (2,4,6,8 axes), 1kHz (16,32 axes)

Communication Channels

Serial ports: one RS-232. One RS-232/422.

Up to 115,200bps

Ethernet channel: TCP/IP 10/100Mbps/sec (10/100 BaseT)

EtherCAT: Two, In & Out, 100 Mbit/sec,

CoE and FoE protocols support

MPU

User Memory: RAM: 128Mb

Non-volatile memory (Flash): 128Mb

Power up Time: 35sec. with no additional

EtherCAT nodes

Environment

Operating: 0 to +40°C. Storage : -25 to +60°C

Humidity: 5% to 90% non-condensing

For the latest updates visit our website at www.acsmotioncontrol.com