



In-Position Technologies

www.iptech1.com | (877) 478-3241 | help@iptech1.com



Precision Reduction Gear RV™

RV

E Series / C Series /
Original Series

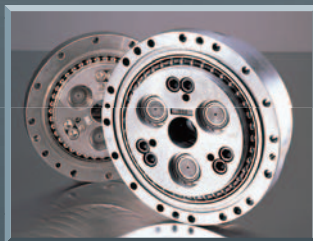
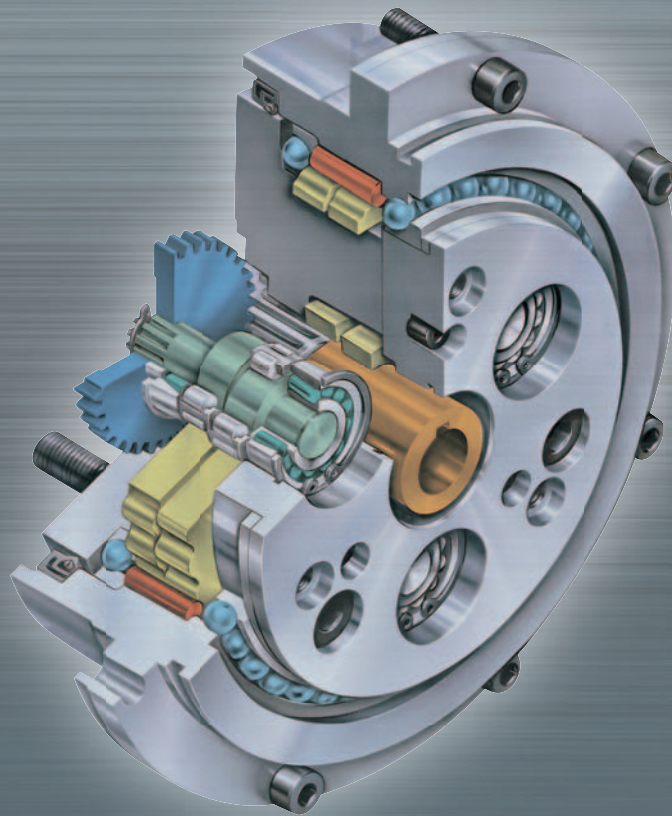

Nabtesco



Contributing to society with our 'Moving it. Stopping it.' technologies

Nabtesco manufactures products which are used in everyday life. Our high-accuracy components are essential for moving objects; they may be rarely visible, but are the foundation of everyday objects that you see moving and wonder how. Nabtesco's technologies are found throughout objects that move and stop people's lives.

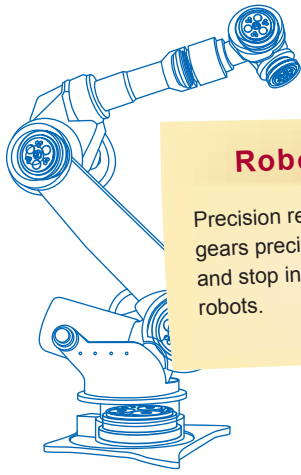

Robots

Precision reduction gears precisely move and stop industrial robots.

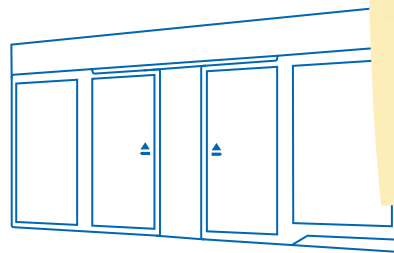

Doors

Nabtesco technology opens and closes automatic doors in buildings and platform doors at train stations.

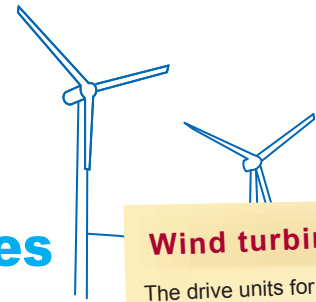

Wind turbines

The drive units for wind turbine generators control the orientation of the wind turbine and the angle of the blades.

Construction machinery

Running motors and control valves start and stop hydraulic excavators.

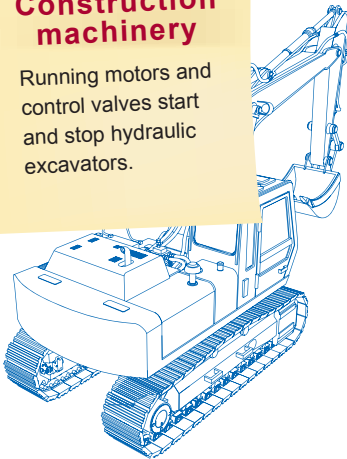

Nabtesco technologies are at work in many areas of our daily lives.

Bullet trains

Brakes and doors ensure safety and comfort for the world-famous Shinkansen bullet trains.

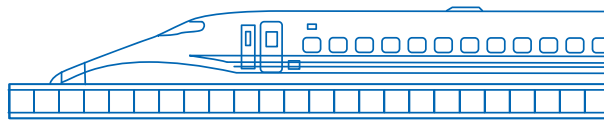

Tankers

The engine remote control systems for vessels move and stop large vessels.

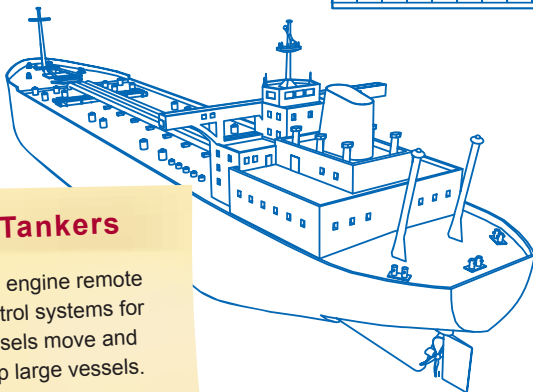

Airplanes

The flight control systems are crucial for the flight safety of aircraft.



CONTENTS

Who is Nabtesco?

The key words for Nabtesco are 'motion control'. We use our strengths in the fields of component and systems technologies to develop highly creative products. Through the Nabtesco Group as a whole, we can also utilize our advantage of expertise to maximum effect in order to further enhance these strengths.

In the air, on land and at sea, we have a large share in various fields of both international and domestic markets. Nabtesco will continue to evolve by utilizing its strengths in many fields and by exploring the possibilities of the future.



Nabtesco

April 2002 Initiation of hydraulic equipment business alliance
October 2003 Business merger

The business alliance between Teijin Seiki and NABCO on hydraulic equipment projects was the beginning of a mutual confirmation by the companies of the other's product configuration, core technologies, corporate strategies and corporate culture. This led to a common recognition that a business merger would be an extremely effective means of increasing corporate value and achieving long-term development. Based on this mutual judgment, in 2003 an equity transfer was conducted to establish Nabtesco as a pure holding company, with both firms as wholly owned subsidiaries. After a year of preparation, both companies were absorbed and amalgamated by means of a short form merger, and Nabtesco was transitioned to an operating holding company.

Precision Reduction Gear RV™	02 – 05
Application Examples	06 – 07
Principle of Speed Reduction	08 – 10
E Series	
Model Codes	11
Rating Table	12 – 13
External Dimensions	14 – 34
Installation Components	35 – 36
C Series	
Model Codes	37
Rating Table	38 – 39
External Dimensions	40 – 52
Installation Components	53 – 55
Original Series	
Model Codes	57
Rating Table	58 – 59
External Dimensions	60 – 73
Installation Components	74 – 79
Technical Information	
Considering the use of Precision Reduction Gear RV™	80
Glossary	81
Product Selection	
Product Selection Flowchart	82
Model Code Selection Examples	83 – 90
Allowable Moment Diagram	91
Technical Data	
No-load running Torque	92
Low Temperature Characteristic	93 – 95
Efficiency Table	96 – 98
Calculation of Tilt Angle and Torsion Angle	99
Design Points	
Mounting Bolts	100
Input Gears	101 – 110
Lubricant VIGOGREASE®	111 – 114
Appendix	
Inertia Moment Calculation Formula	115
Troubleshooting Checksheet	116
APPLICATION WORKSHEET	117
VIGOGREASE® Ordering Information	118
Warranty	Back inside cover

PRECISION REACHES A NEW LEVEL

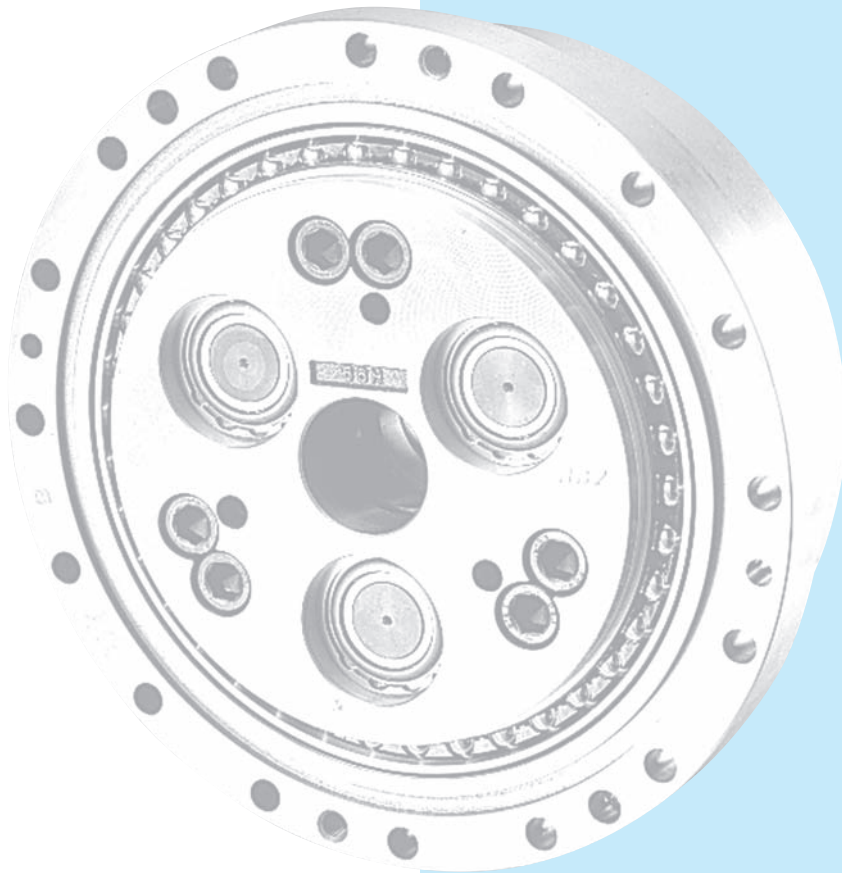

RV®

The RV E, C, and Original Series are family of planocentric reduction gear mechanisms designed for precise motion control. The mechanisms incorporate a large number of simultaneously engaged gear teeth, and have compact, lightweight and highly rigid construction that is strong against overloading.

Furthermore, minimal backlash, rotary vibration and inertia assure rapid acceleration, smooth motion and extremely accurate positioning.

The Precision Reduction Gear RV is ideally suited for precision mechanical control in factory robots, machine tools, and assembly and conveying equipment where precise positioning, stiffness and shock-load capability are demanded.

Features and construction of E series

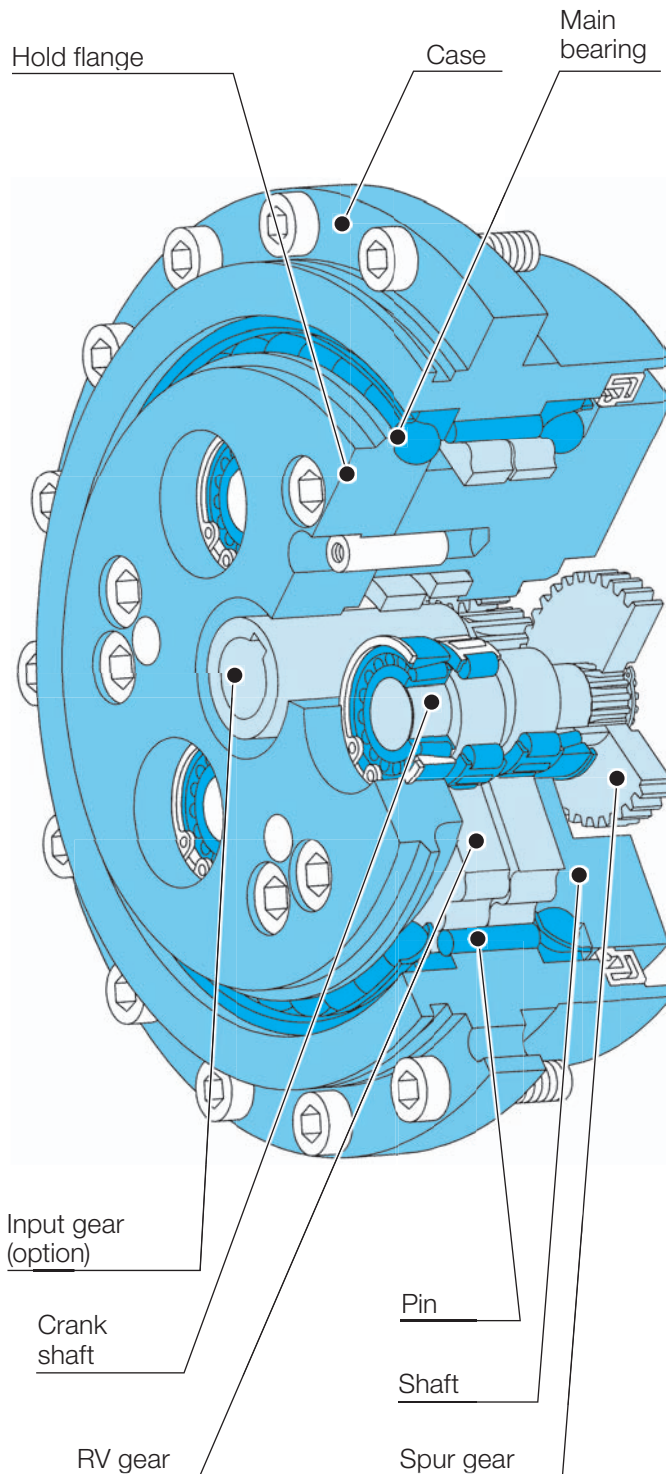

Integrated angular ball bearings

Benefits:

- Increases reliability
- Reduces overall cost

Attributed to:

- Built-in angular ball bearing construction improves the ability to support external loads, increases moment rigidity and maximum allowable moment.
- Reduces the number of components required.
- Simplifies installation.

2-stage reduction

Benefits:

- Reduces vibration
- Reduces inertia (GD^2)

Attributed to:

- Low speed rotation of the RV gear reduces vibration.
- Reduced size of the motor coupling part (input gear) lowers inertia.

All main elements are supported on both sides

Benefits:

- Higher torsional stiffness
- Less vibration
- High shock load capability (5 times rated torque)

Detail:

- Crankshafts are supported on both sides of the reduction gear as shown below.

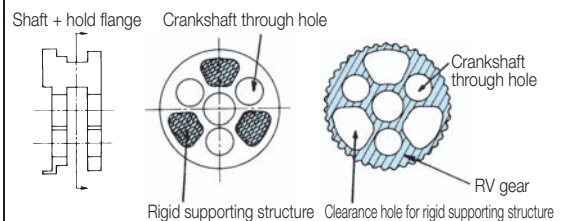

Rolling contact elements

Benefits:

- Excellent starting efficiency
- Low wear and longer life
- Low backlash (1 arc. min.)

Attributed to:

- Use of roller bearings throughout.

Pin & gear structure

Benefits:

- Very low backlash (1 arc. min.)
- Higher shock load capability (5 times rated torque)

Attributed to:

- Synchroneshing of many RV gear teeth and pins.

Precision Reduction Gear RV™

Features and construction of C series

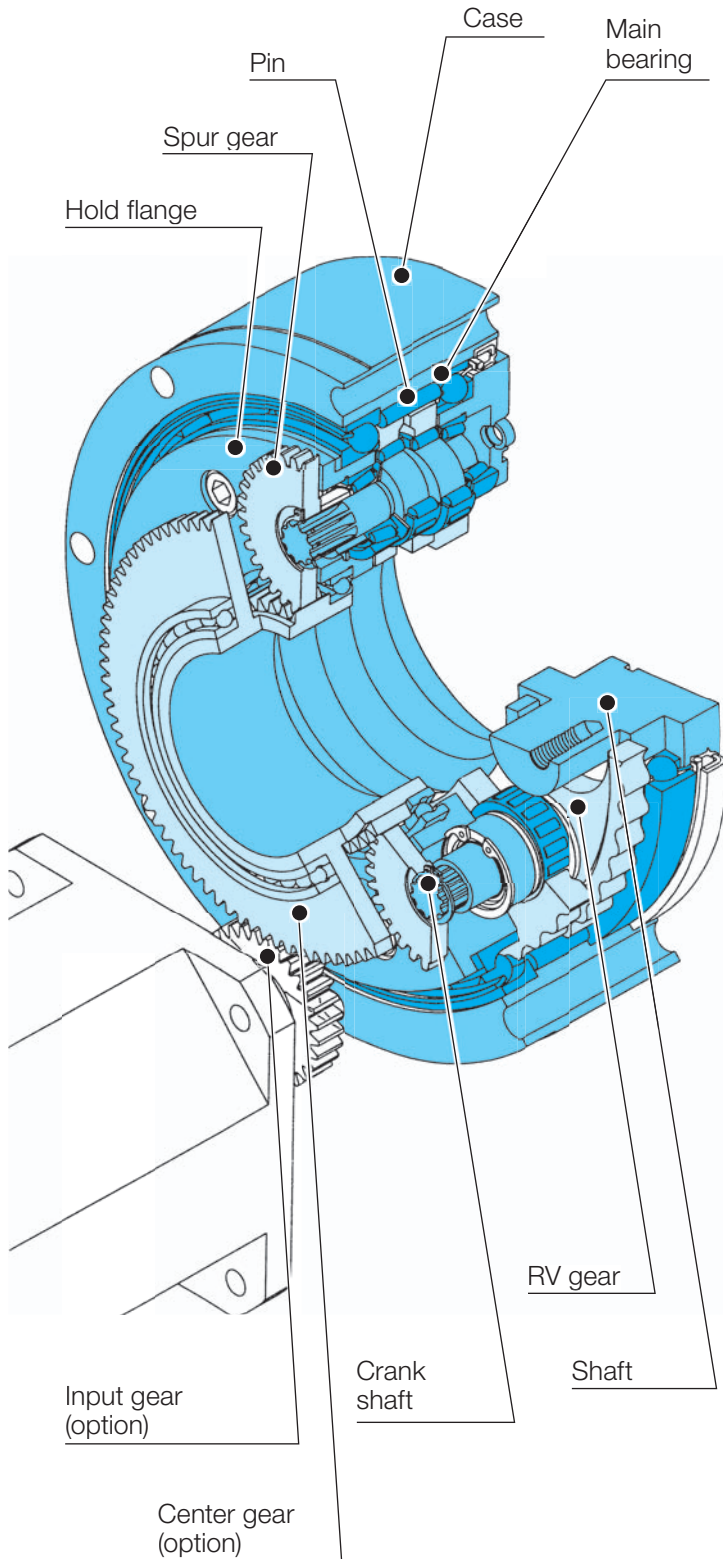

Hollow shaft structure

- Cables and other lines can pass through the reduction gear
- Allows space saving design

Integrated angular ball bearings

Benefits:

- Increases reliability
- Reduces overall cost

Attributed to:

- Built-in angular ball bearing construction improves the ability to support external loads and increases moment rigidity and maximum allowable moment. As a result, this model can be used for the rotary axis.
- Reduces the number of components required.
- Simplifies installation.

2-stage reduction

Benefits:

- Reduces vibration
- Reduces inertia (GD^2)

Attributed to:

- Low speed rotation of the RV gear reduces vibration.
- Reduced size of the motor coupling part (input gear) lowers inertia.

All main elements are supported from both sides

Benefits:

- Higher torsional stiffness
- Less vibration
- High shock load capability (5 times rated torque)

Detail:

- Crankshafts are supported on both sides of the reduction gear as shown below.

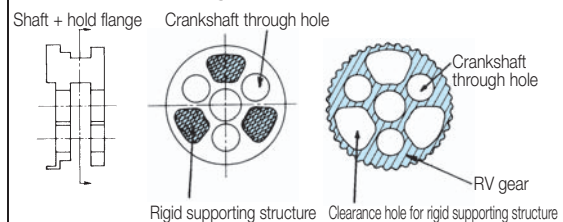

Rolling contact elements

Benefits:

- Excellent starting efficiency
- Low wear and longer life
- Low backlash (1 arc. min.)

Attributed to:

- Use of roller bearings throughout.

Pin & gear structure

Benefits:

- Very low backlash (1 arc. min.)
- Higher shock load capability (5 times rated torque)

Attributed to:

- Synchroneshing of many RV gear teeth and pins.

Features and construction of Original series

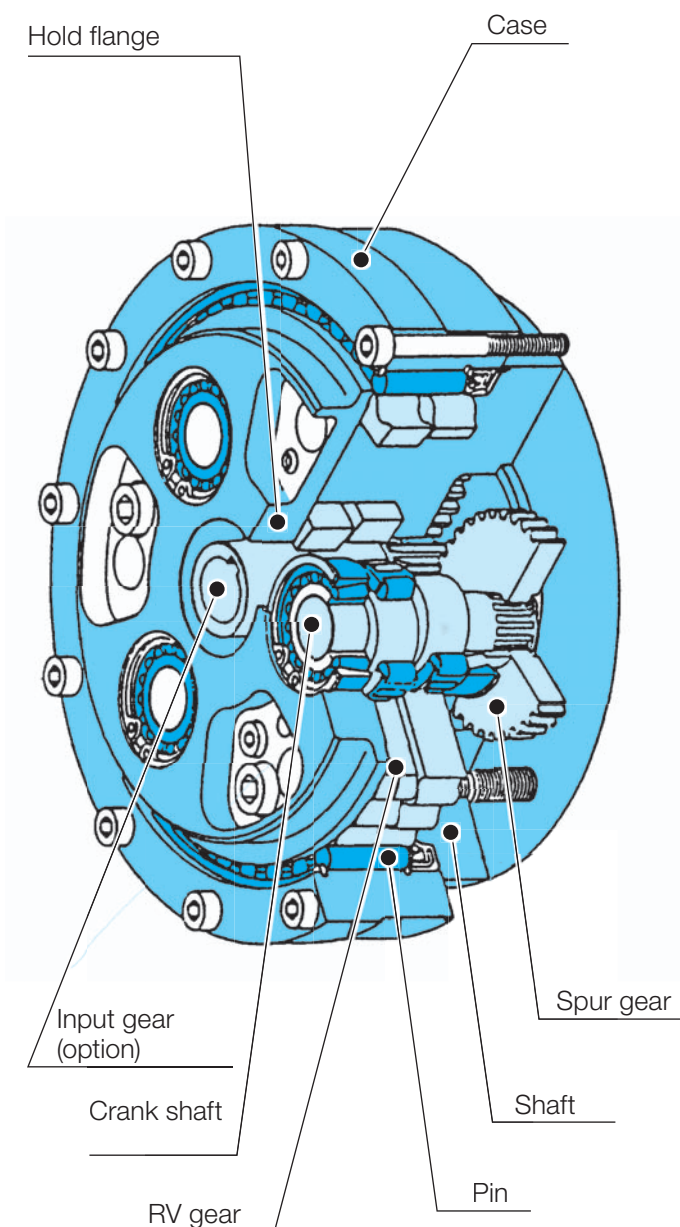

2-stage reduction

Benefits:

- Reduces vibration
- Reduces inertia (GD^2)

Attributed to:

- Low speed rotation of the RV gear reduces vibration.
- Reduced size of the motor coupling part (input gear) lowers inertia.

All main elements are supported on both sides

Benefits:

- Higher torsional stiffness
- Less vibration
- High shock load capability

Detail:

- Crankshafts are supported on both sides of the reduction gear as shown below.

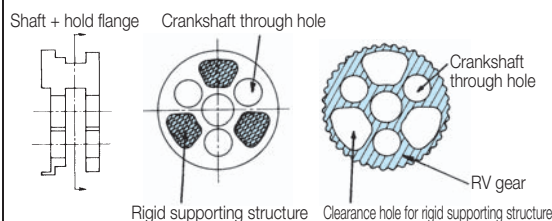

Rolling contact elements

Benefits:

- Excellent starting efficiency
- Low wear and longer life
- Low backlash (1 arc. min.)

Attributed to:

- Use of roller bearings throughout.

Pin & gear structure

Benefits:

- Very low backlash (1 arc. min.)
- Higher shock load capability (5 times rated torque)

Attributed to:

- Synchromeshing of many RV gear teeth and pins.

External support structure for main bearing

- Separate installation of the main bearing supports a larger moment.
- Installation on the output shaft supports a reduced diameter.

Application Examples

C series

Robot swing axis

- Allows space-saving design
- Main bearing is not required on robot side.

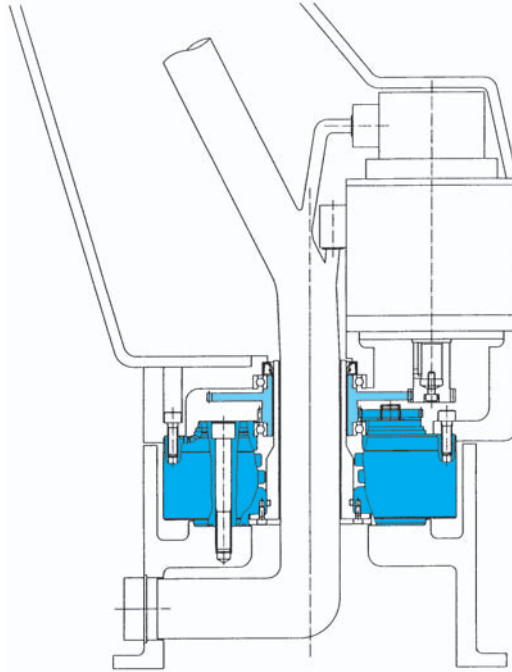

Robot arm

- As cables can be passed through the arm, environmental resistance increases.
- Wider operating angle.

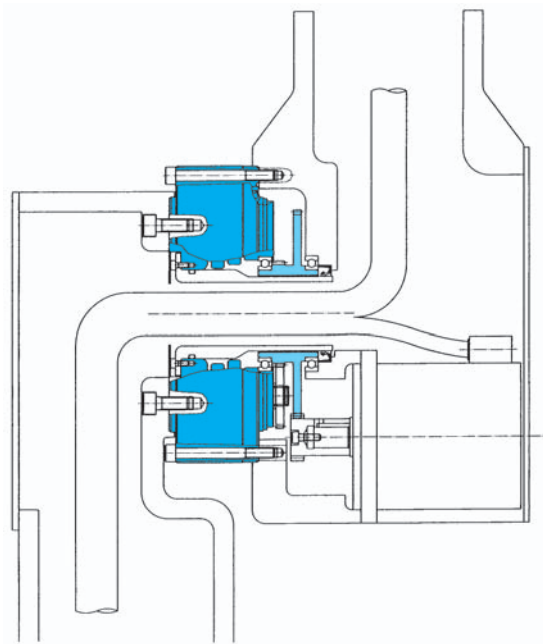

Indexing table

- The table can be made into a hollow shaft structure.

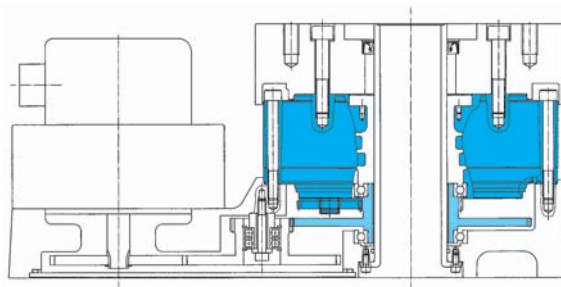

E series

Robot arm

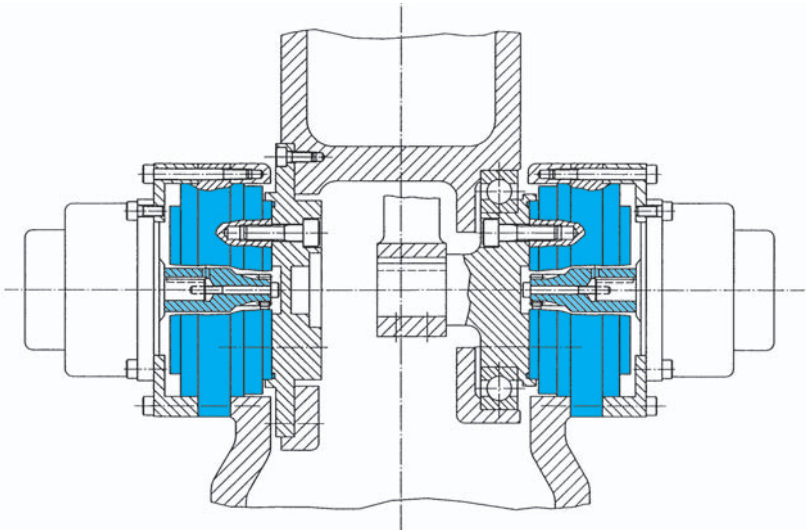

Robot wrist axis

As shown in the figure(right), the input gear can also be supported within the reduction gear mechanism. Please contact Nabtesco for more details.

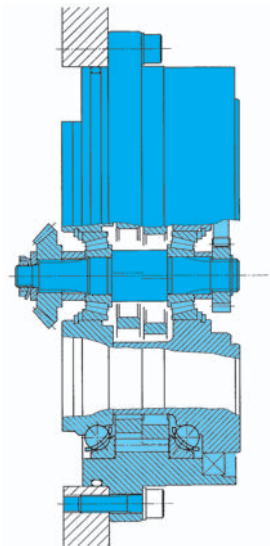

Original series

Robot swing axis

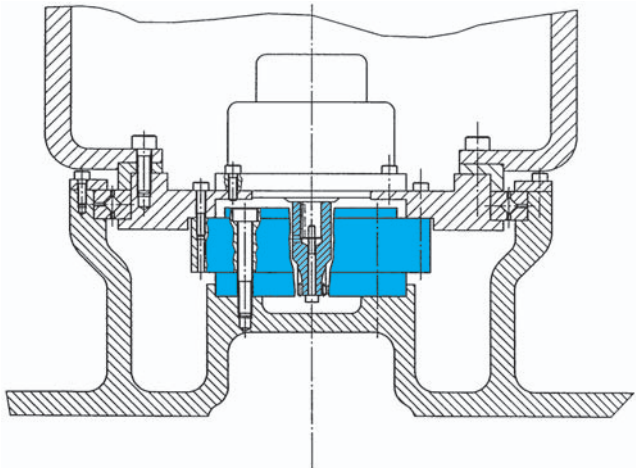

Principle of Speed Reduction

1st stage ...Spur gear reduction

- An input gear engages with and rotates spur gears that are coupled to crankshafts. Several overall gear ratios can be provided by selecting various first stage ratios.

2nd stage ...Epicyclic gear reduction

- Crankshafts driven by the spur gears cause an eccentric motion of two epicyclic gears called RV gears that are offset 180 degrees from one another to provide a balanced load.
- The eccentric motion of the RV gears causes engagement of the cycloidal shaped gear teeth with cylindrically shaped pins located around the inside edge of the case.
- In the course of one revolution of the crankshafts the teeth of the RV gear move the distance of one pin in the opposite direction of the rotating cranks. The motion of the RV gear is such that the teeth remain in close contact with the pins and multiple teeth share the load simultaneously.
- The output can be either the shaft or the case. If the case is fixed, the shaft is the output. If the shaft is fixed, the case is the output.

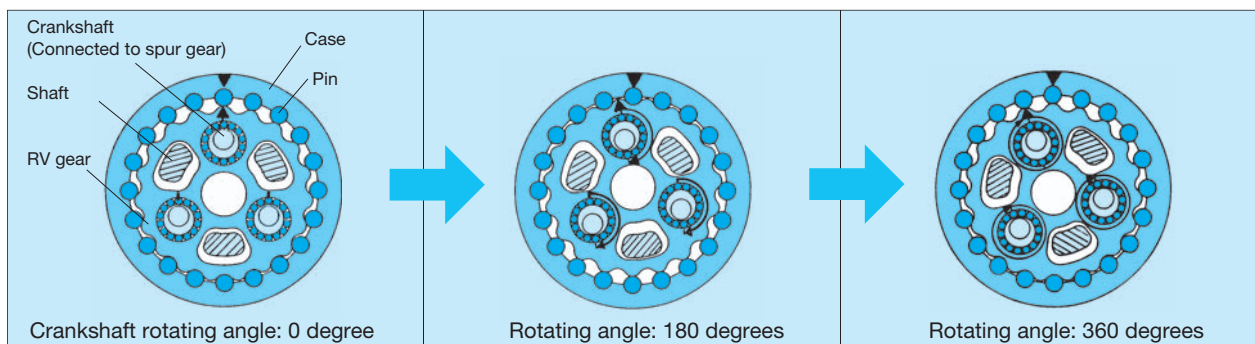

Rotary direction and speed ratio

Both the E series and Original series may be used in various ways. The following figures show six combinations of the rotary direction and speed ratio. Use the following figure to select a mechanism most suitable for your application.

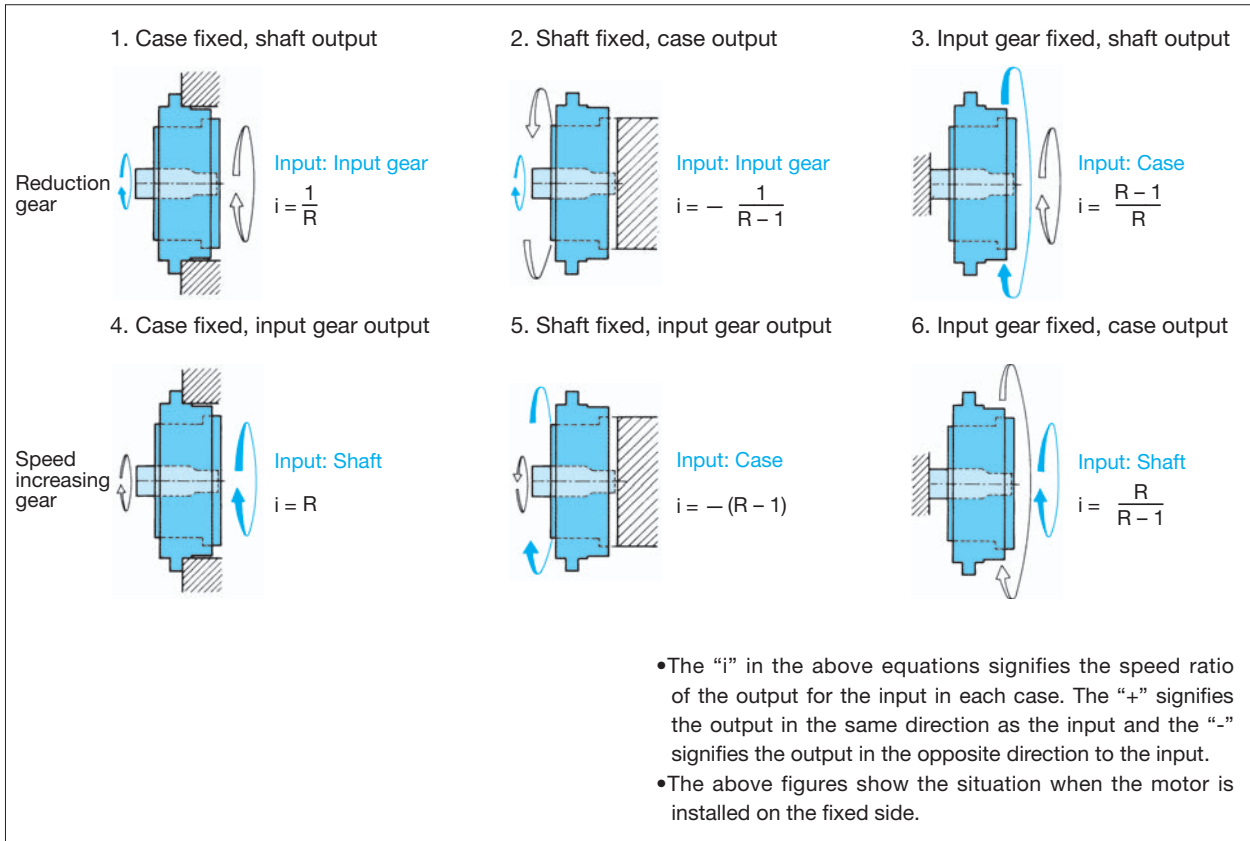

Speed ratio

The overall reduction ratio *i* (of the First and Second reduction stages) will differ depending on the use, and can be calculated using the speed ratio values displayed in the table below.

With the shaft as output; $R = 1 + \frac{Z_2}{Z_1} \cdot Z_4$

$i = \frac{1}{R}$

R : Speed ratio
*Z*₁ : Number of teeth on input gear
*Z*₂ : Number of teeth on spur gear
*Z*₃ : Number of teeth on RV gear
*Z*₄ : Number of pins
i : Reduction ratio

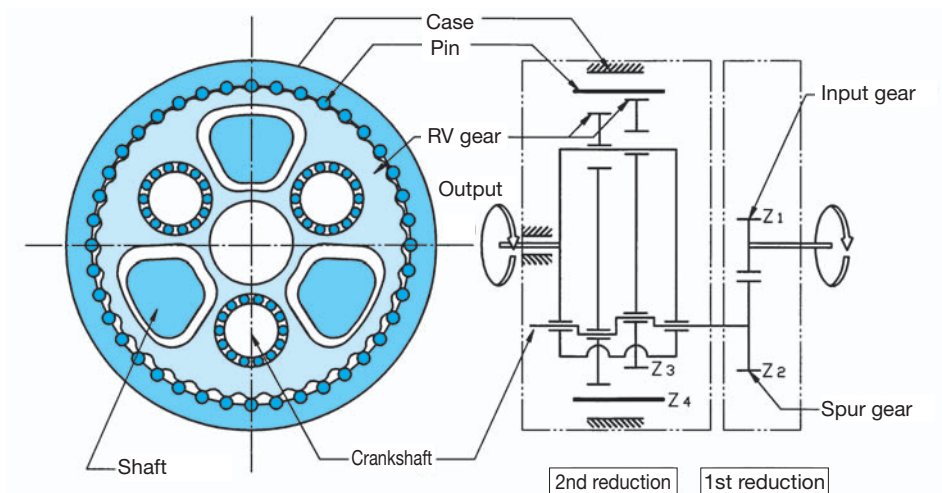

Principle of Speed Reduction

Rotary direction and speed ratio

The rotary direction and speed ratio of the C series are shown below.

<p>1. Case fixed, shaft output</p> <p>Reduction gear Input: Input gear $i = \frac{1}{R_1}$</p>	<p>2. Shaft fixed, case output</p> <p>Input: Input gear $i = \frac{1}{R_1-1}$</p>	<p>3. Input gear fixed, shaft output</p> <p>Input: Case $i = \frac{R_1-1}{R_1}$</p>
<p>4. Case fixed, input gear output</p> <p>Speed increasing gear Input: Shaft $i = R_1$</p>	<p>5. Shaft fixed, input gear output</p> <p>Input: Case $i = R_1-1$</p>	<p>6. Input gear fixed, case output</p> <p>Input: Shaft $i = \frac{R_1}{R_1-1}$</p>

Installation example (motor installed on case side of reduction gear)

<p>1. Case is fixed, shaft output</p> <p>$i = -\frac{1}{R_1}$</p>	<p>2. Shaft fixed, case output</p> <p>$i = \frac{1}{R_1}$</p>
--	--

- The "i" in the above equations signifies the speed ratio of the output for the input in each case. The "+" signifies the output in the same direction as the input and the "-" signifies the output in the opposite direction to the input.
- The above figures show the situation when the motor is installed on the fixed side.

Mechanism block drawing

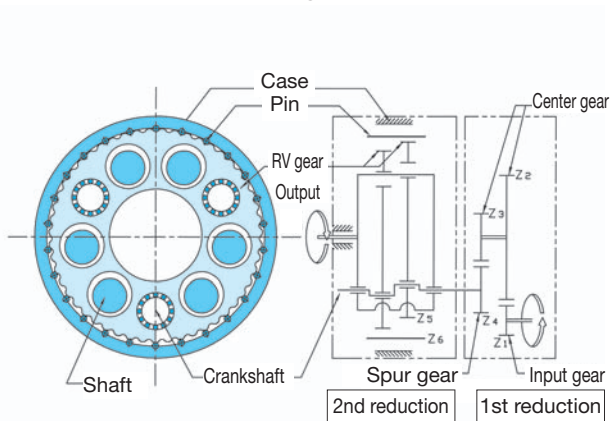

Speed ratio

The overall reduction ratio i (of the First and Second reduction stages) will differ depending on the use, and can be calculated using the speed ratio values displayed in the table below.

With the shaft as output;

$$R = R_1 \times \frac{Z_2}{Z_1}$$

$$i = -\frac{1}{R}$$

$$(R_1 = 1 + \frac{Z_4}{Z_3} \cdot Z_6)$$

- R : Overall speed ratio
- R_1 : Speed ratio of a discrete reduction gear
- Z_1 : Number of teeth on input gear
- Z_2 : Number of teeth on large center gear
- Z_3 : Number of teeth on small center gear
- Z_4 : Number of teeth on spur gear
- Z_5 : Number of teeth on RV gear
- Z_6 : Number of pins
- i : Reduction ratio

Note: The speed ratio values and rotation directions shown above indicate when the motor (motor fixing component) is installed on the case side of the reduction gear.



Precision Reduction Gear RV™ Eseries

Model Codes

Explanation of codes

•When placing an order or making an inquiry, please use the following codes to specify the appropriate model.

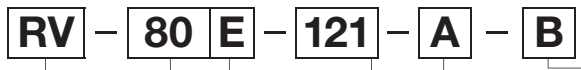

Model code	Frame number	Series code	Ratio code	Input gear code Input spline code	Output shaft clamp code
RV	6	E: Main bearing built-in type	31, 43, 53.5, 59, 79, 103	A: Standard gear A B: Standard gear B Z: No gear	B: Bolt-clamping output shaft type P: Pin/bolt clamping output shaft type
	20		57, 81, 105, 121, 141, 161		
	40		57, 81, 105, 121, 153		
	80		57, 81, 101, 121, 153		
	110		81, 111, 161, 175		
	160		81, 101, 129, 145, 171		
	320		81, 101, 118.5, 129, 141, 171, 185		
	450		81, 101, 118.5, 129, 154.8, 171, 192.4		

Rating Table

Output speed (rpm)				5	10	15	20	25	30	40	50	60
Model	Ratio code	R Speed ratio		Output torque (Nm) / input capacity (kW)								
		Shaft rotation	Case rotation									
RV-6E	31	31	30	101 / 0.07	81 / 0.11	72 / 0.15	66 / 0.19	62 / 0.22	58 / 0.25	54 / 0.30	50 / 0.35	47 / 0.40
	43	43	42									
	53.5	53.5	52.5									
	59	59	58									
	79	79	78									
103	103	102										
RV-20E	57	57	56	231 / 0.16	188 / 0.26	167 / 0.35	153 / 0.43	143 / 0.50	135 / 0.57	124 / 0.70	115 / 0.81	110 / 0.92
	81	81	80									
	105	105	104									
	121	121	120									
	141	141	140									
161	161	160										
RV-40E	57	57	56	572 / 0.40	465 / 0.65	412 / 0.86	377 / 1.05	353 / 1.23	334 / 1.40	307 / 1.71	287 / 2.00	271 / 2.27
	81	81	80									
	105	105	104									
	121	121	120									
	153	153	152									
RV-80E	57	57	56	1,088 / 0.76	885 / 1.24	784 / 1.64	719 / 2.01	672 / 2.35	637 / 2.67	584 / 3.26	546 / 3.81	517 / 4.33
	81	81	80									
	101	101	100									
	121	121	120									
	153	"(153)	"(152)									
RV-110E	81	81	80	1,499 / 1.05	1,215 / 1.70	1,078 / 2.26	990 / 2.76	925 / 3.23	875 / 3.67	804 / 4.49		
	111	111	110									
	161	161	160									
	175	1227/7	1220/7									
RV-160E	81	81	80	2,176 / 1.52	1,774 / 2.48	1,568 / 3.28	1,441 / 4.02	1,343 / 4.69	1,274 / 5.34			
	101	101	100									
	129	129	128									
	145	145	144									
171	171	170										
RV-320E	81	81	80	4,361 / 3.04	3,538 / 4.94	3,136 / 6.57	2,881 / 8.05	2,695 / 9.41	2,548 / 10.7			
	101	101	100									
	118.5	118.5	117.5									
	129	129	128									
	141	141	140									
	171	171	170									
185	185	184										
RV-450E	81	81	80	6,135 / 4.28	4,978 / 6.95	4,410 / 9.24	4,047 / 11.3	3,783 / 13.2				
	101	101	100									
	118.5	118.5	117.5									
	129	129	128									
	154.8	2013/13	2000/13									
	171	171	170									
192	1347/7	1340/7										

Note: 1. The allowable output speed will differ depending upon the duty ratio, load, and ambient temperature. Contact us regarding use above the allowable output speed N_{s1}.

2. The input capacity (kW) is calculated according to the following calculation formula:

$$\text{Input capacity (kW)} = \frac{2\pi \cdot N \cdot T}{60 \cdot \frac{\eta}{100} \cdot 10^3}$$

N: Output speed (rpm)
T: Output torque (Nm)
η = 75: Reduction gear efficiency (%)

Note: The input capacity is a reference value.

3. When the reduction gear is used at low temperatures, there will be a larger no-load running torque. Note this characteristic when selecting a motor.
(Refer to "Low temperature characteristic" on page 93)

T ₀ Rated torque (Note 7)	N ₀ Rated output Speed	K Rated service life	T _{S1} Allowable acceleration/ deceleration torque	T _{S2} Momentary maximum allowable torque	N _{S0} Maximum allowable output speed (Note 1)	Backlash	Lost motion MAX.	Angular transmission error MAX.	Startup efficiency (Typical value)	M ₀₁ Allowable moment (Note 4)	M ₀₂ Momentary allowable moment (Max.)	W _r Allowable radial load (Note 10)	Reduced value of the inertia moment for the input shaft (Note 5)	Weight
(Nm)	(rpm)	(h)	(Nm)	(Nm)	(r/min)	(arc.min.)	(arc.min.)	(arc.sec.)	(%)	(Nm)	(Nm)	(N)	(kgm ²)	(kg)
58	30	6,000	117	294	100	1.5	1.5	80	70	196	392	2,139	2.63×10 ⁻⁶	2.5
													2.00×10 ⁻⁶	
													1.53×10 ⁻⁶	
													1.39×10 ⁻⁶	
													1.09×10 ⁻⁶	
0.74×10 ⁻⁶														
167	15	6,000	412	833	75	1.0	1.0	70	75	882	1,764	7,784	9.66×10 ⁻⁶	4.7
													6.07×10 ⁻⁶	
													4.32×10 ⁻⁶	
													3.56×10 ⁻⁶	
													2.88×10 ⁻⁶	
2.39×10 ⁻⁶														
412	15	6,000	1,029	2,058	70	1.0	1.0	60	85	1,666	3,332	11,593	3.25×10 ⁻⁵	9.3
													2.20×10 ⁻⁵	
													1.63×10 ⁻⁵	
													1.37×10 ⁻⁵	
1.01×10 ⁻⁵														
784	15	6,000	1,960	Bolt joint 3,920	70	1.0	1.0	50	85	Bolt joint 2,156	Bolt joint 4,312	Bolt joint 12,987	8.16×10 ⁻⁵	Bolt joint 13.1
				Pin/bolt joint 3,185						Pin/bolt joint 1,735	Pin/bolt joint 2,156	Pin/bolt joint 10,451	6.00×10 ⁻⁵	Pin/bolt joint 12.7
													4.82×10 ⁻⁵	
													3.96×10 ⁻⁵	
												2.98×10 ⁻⁵		
1,078	15	6,000	2,695	5,390	50	1.0	1.0	50	85	2,940	5,880	16,647	9.88×10 ⁻⁵	17.4
													6.96×10 ⁻⁵	
													4.36×10 ⁻⁵	
													3.89×10 ⁻⁵	
1,568	15	6,000	3,920	Bolt joint 7,840	45	1.0	1.0	50	85	3,920	Bolt joint 7,840	18,587	1.77×10 ⁻⁴	26.4
				Pin/bolt joint 6,615							Pin/bolt joint 6,762		1.40×10 ⁻⁴	
													0.87×10 ⁻⁴	
													0.74×10 ⁻⁴	
3,136	15	6,000	7,840	Bolt joint 15,680	35	1.0	1.0	50	80	Bolt joint 7,056	Bolt joint 14,112	Bolt joint 28,066	4.83×10 ⁻⁴	44.3
				Pin/bolt joint 12,250						Pin/bolt joint 6,174	Pin/bolt joint 10,976	Pin/bolt joint 24,558	3.79×10 ⁻⁴	
													3.15×10 ⁻⁴	
													2.84×10 ⁻⁴	
												1.97×10 ⁻⁴		
												1.77×10 ⁻⁴		
4,410	15	6,000	11,025	Bolt joint 22,050	25	1.0	1.0	50	85	8,820	Bolt joint 17,640	30,133	8.75×10 ⁻⁴	66.4
				Pin/bolt joint 18,620							Pin/bolt joint 13,524		6.91×10 ⁻⁴	
													5.75×10 ⁻⁴	
													5.20×10 ⁻⁴	
													4.12×10 ⁻⁴	
												3.61×10 ⁻⁴		
												3.07×10 ⁻⁴		

Note: 4. The allowable moment will differ depending on the thrust load. Check the allowable moment diagram (p. 91).

5. The inertia moment value is for the reduction gear. It does not include the inertia moment for the input gear.

6. For the moment rigidity and torsional rigidity, refer to the calculation of tilt angle and the torsion angle (p. 99).

7. The rated torque is the value that produces the rated service life based on operation at the rated output speed; it does not indicate the maximum load. Refer to the "Glossary" (p.81) and the "Product selection flowchart" (p.82).

8. Contact us regarding speed ratios other than those listed above.

9. The specifications above are based on Nabtesco evaluation methods; this product should only be used after confirming that it is appropriate for the operating conditions of your system.

10. When radial load b is applied within dimension b, use the reduction gear within the allowable radial load.

11. *1 The R=153 for the RV-80E is only for the bolt-clamping output shaft type (page 20, 21).

Design Points

Installation Components

Design of the motor mounting flange

In order to avoid contact with reduction gear components, refer to the sizes indicated in the “External Dimensions” drawings when designing the motor mounting flange.

Note: The size and number of bolts for the motor mounting flange should be determined with the torque and moment taken into consideration, and should be positioned in line with the reduction gear’s case mounting holes. After installing the reduction gear, we recommend installing an add/drain grease fitting to enable grease replacement. An installation example is shown below. Use the specified tightening torque to uniformly tighten the hexagon socket head cap screws (with corresponding conical spring washers).

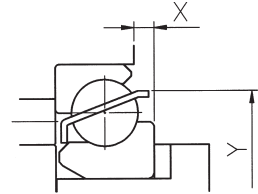

	X	Y
RV-6E	MAX1.9	MAX ϕ 85
RV-320E	MAX3.2	MAX ϕ 222.2
RV-450E	MAX5.5	MAX ϕ 285

With other models, the retainer does not stick out from the casing.

To obtain maximum performance from the E series, it is important to optimally design the assembly, installation, lubrication, and sealing. Be sure to read the following precautions before designing the above. As angular ball bearings are used as the main bearings, design the mating component dimensions according to the table on the right to make sure that the bearing retainer does not come in contact with the motor mounting flange.

Assembly accuracy

Design the motor mounting flange to the following accuracy. Poor assembly accuracy causes vibration and noise.

Unit: mm

Model	Tolerance for concentricity		Concentricity tolerance	
	a	Type	a	
RV-6E	MAX0.03	RV-110E	MAX0.03	
RV-20E	MAX0.03	RV-160E	MAX0.05	
RV-40E	MAX0.03	RV-320E	MAX0.05	
RV-80E	MAX0.03	RV-450E	MAX0.05	

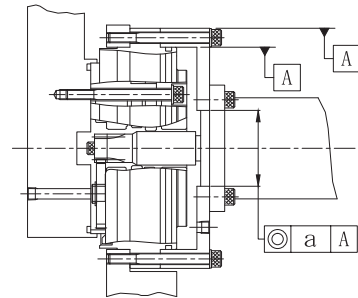

Installation procedure

- Typical installation examples for reduction gears to be mounted on the mating components are shown below. Be sure to apply the specified amount of the specified grease during assembly. (See page 111-112)
- Refer to the O-ring seals shown to make a seal design for the mounting side.
- If O-ring (II) cannot be used due to the structure, apply the appropriate liquid sealant from the table on the right.
- If a seal cannot be formed by applying liquid sealants due to the structure, use O-ring (I) and (III) on page 36.

Recommended liquid sealant

Manufacturer	Characteristics and applications
ThreeBond 1211 (ThreeBond Co.)	<ul style="list-style-type: none"> • Silicone-based, solventless type • Semi-dry gasket
HermeSeal SS-60F (Nihon Hermetics Co.)	<ul style="list-style-type: none"> • One-part, non-solvent elastic sealant • Metal contact side (flange surface) seal • Any product basically equivalent to ThreeBond 1211
Loctite 515 (Henkel)	<ul style="list-style-type: none"> • Anaerobic flange sealant • Metal contact side (flange surface) seal

Notes 1. Do not use these sealants for copper material or copper alloy material.
2. If these sealants need to be used under special conditions such as concentrated alkali, pressurized steam, etc., please contact Nabtesco.

• Bolt clamping output shaft type

Note: The sizes of bolts for tightening the output shaft are not all the same. Make sure that each bolt is tightened with the specified torque after assembling.

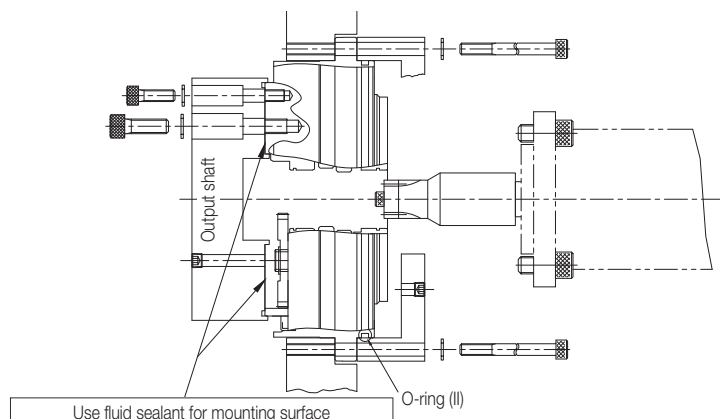

O-ring (II)

	Applicable O-ring
RV-6E	S100
RV-20E	S120
RV-40E	AS568-258
RV-80E	AS568-263
RV-110E	G190
RV-160E	G220
RV-320E	G270
RV-450E	G300

Design Points

Installation Components

•Pin/bolt clamping output shaft type

Note: The prepared pinhole and the output shaft need to be reamed jointly with a reamer before knocking in the taper pin.
The reduction gear needs to be appropriately masked during reaming to prevent chips from entering inside.

Installation of RV-20E, 40E

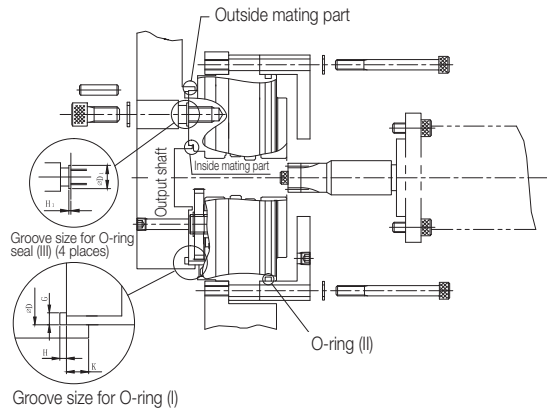

Installation of RV-160E, 320E, 450E

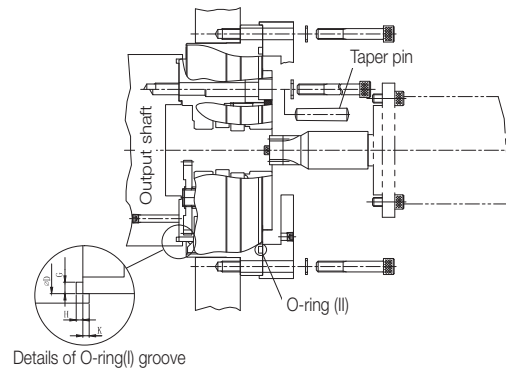

Installation example for RV-80E

A different method is used on RV-80E to knock in the taper pin, so follow the next procedure for assembling.

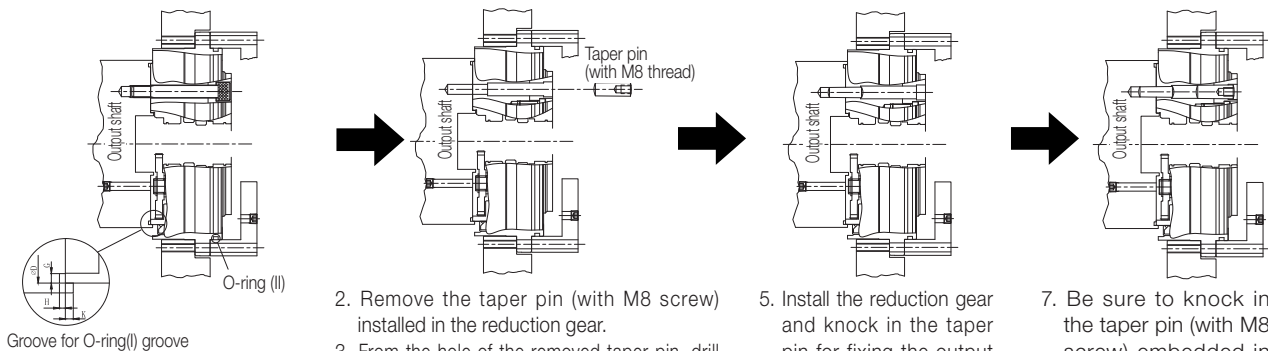

1. Loosely tighten the hexagon socket head cap screw to temporarily secure the reduction gear shaft to the output shaft.
2. Remove the taper pin (with M8 screw) installed in the reduction gear.
3. From the hole of the removed taper pin, drill a hole for the taper pin (10 mm. dia.) in the output shaft. (At this time, masking is needed to prevent chips from entering the reduction gear.)
4. After reaming, remove the bolt to remove the reduction gear, then remove any chips and burrs.
5. Install the reduction gear and knock in the taper pin for fixing the output shaft.
6. Tighten the hexagon socket head cap screw securely to fix the reduction gear to the output shaft.
7. Be sure to knock in the taper pin (with M8 screw) embedded in the reduction gear. Use a taper pin with screw.

Dimensions for O-ring (I) seal

(Unit: mm)

		For RV-20E(A)	For RV-20E(B)	For RV-40E	For RV-80E	For RV-110E	For RV-160E	For RV-320E	For RV-450E	
Dimensions	O-ring	ID No.	AS568-045	S100	S132	AS568-163	AS568-167	AS568-265	AS568-271	AS568-275
		Wire dia.	ø 1.78 ±0.07	ø 2.0 ±0.1	ø 2.0 ±0.1	ø 2.62 ±0.07	ø 2.62 ±0.07	ø 3.53 ±0.1	ø 3.53 ±0.1	ø 3.53 ±0.1
		I. D.	ø 101.32 ±0.38	ø 99.5 ±0.4	ø 131.5 ±0.6	ø 152.07 ±0.58	ø 177.47 ±0.58	ø 196.44 ±0.76	ø 234.54 ±0.76	ø 266.29 ±0.76
	Groove dimensions	Outside dia.: D	ø 105	ø 105	ø 135	ø 160	ø 182	ø 204	ø 243	ø 273
		Depth: H	1.27 ±0.05	1.5 $\begin{smallmatrix} 0 \\ -0.1 \end{smallmatrix}$	1.5 $\begin{smallmatrix} 0 \\ -0.1 \end{smallmatrix}$	2.06 ±0.05	2.06 ±0.05	2.82 ±0.05	2.82 ±0.05	2.82 ±0.05
	Width: G	2.39 $\begin{smallmatrix} +0.25 \\ 0 \end{smallmatrix}$	2.7 $\begin{smallmatrix} +0.25 \\ 0 \end{smallmatrix}$	2.7 $\begin{smallmatrix} +0.25 \\ 0 \end{smallmatrix}$	3.58 $\begin{smallmatrix} +0.25 \\ 0 \end{smallmatrix}$	3.58 $\begin{smallmatrix} +0.25 \\ 0 \end{smallmatrix}$	4.78 $\begin{smallmatrix} +0.25 \\ 0 \end{smallmatrix}$	4.78 $\begin{smallmatrix} +0.25 \\ 0 \end{smallmatrix}$	4.78 $\begin{smallmatrix} +0.25 \\ 0 \end{smallmatrix}$	
	Height: K (For reference)	3	3	3	3	3	4	4	4	

O-ring (II) seal dimensions

(Unit: mm)

	For RV-20E	For RV-40E	For RV-80E	For RV-160E	For RV-320E	For RV-450E
ID No.	S120	AS568-258	AS568-263	G220	G270	G300

Dimensions for O-ring (III) seal

(Unit: mm)

		For RV-20E	For RV-40E	
Dimensions	O-ring	ID No.	S12.5	S14
		Wire dia.	ø 1.5 ±0.1	ø 1.5 ±0.1
		I. D.	ø 12	ø 13.5
	Groove dimensions	Outside dia.: D ₁	ø 14.8 ±0.1	ø 16.3 ±0.1
Depth: H ₁		1 $\begin{smallmatrix} 0 \\ -0.1 \end{smallmatrix}$	1 $\begin{smallmatrix} 0 \\ -0.1 \end{smallmatrix}$	

- Notes
1. Use O-ring seal of either type (A) or type (B).
 2. The S type ID number is the manufacturer's own standard.



Precision Reduction Gear RV™ Cseries

Model Codes

Explanation of codes

•When placing an order or making an inquiry, please use the following codes to specify the appropriate model.

RV - **100** **C** - **36.75** - **A** - **B**

Model code	Frame number	Series code	Ratio code	Center gear code	Output shaft clamp code
RV	10	C: Hollow shaft type	27	A: Standard gear A B: Standard gear B Z: No gear	B: Bolt-clamping output shaft type T: Through-bolt clamping output shaft type
	27		36.57		
	50		32.54		
	100		36.75		
	200		34.86		
	320		35.61		
	500		37.34		

Rating Table

Output speed (rpm)				5	10	15	20	25	30	40	50	60
Model	Ratio code	R Speed ratio		Output torque (Nm) / input capacity (kW)								
		Shaft rotation	Case rotation									
RV-10C	27	27	26	136 / 0.09	111 / 0.16	98 / 0.21	90 / 0.25	84 / 0.29	80 / 0.34	73 / 0.41	68 / 0.47	65 / 0.54
RV-27C	36.57	1,390/38	1352/38	368 / 0.26	299 / 0.42	265 / 0.55	243 / 0.68	227 / 0.79	215 / 0.90	197 / 1.10	184 / 1.29	174 / 1.46
RV-50C	32.54	1,985/61	1924/61	681 / 0.48	554 / 0.77	490 / 1.03	450 / 1.26	420 / 1.47	398 / 1.67	366 / 2.04	341 / 2.38	
RV-100C	36.75	36.75	35.75	1,362 / 0.95	1,107 / 1.55	980 / 2.05	899 / 2.51	841 / 2.94	796 / 3.33	730 / 4.08		
RV-200C	34.86	1,499/43	1456/43	2,724 / 1.90	2,215 / 3.09	1,960 / 4.11	1,803 / 5.04	1,686 / 5.88	1,597 / 6.69			
RV-320C	35.61	2,778/78	2700/78	4,361 / 3.04	3,538 / 4.94	3,136 / 6.57	2,881 / 8.05	2,690 / 9.41				
RV-500C	37.34	3,099/83	3016/83	6,811 / 4.75	5,537 / 7.73	4,900 / 10.26	4,498 / 12.56					

Note: 1. The allowable output speed will differ depending upon the duty ratio, load, and ambient temperature. Contact us regarding use above the allowable output speed N_{s1} .

2. The input capacity (kW) is calculated according to the following calculation formula:

$$\text{Input capacity (kW)} = \frac{2\pi \cdot N \cdot T}{60 \cdot \frac{\eta}{100} \cdot 10^3}$$

N : Output speed (rpm)
 T : Output torque (Nm)
 η : Reduction gear efficiency (%)

Note: The input capacity is a reference value.

3. When the reduction gear is used at low temperatures, there will be a larger no-load running torque. Note this characteristic when selecting a motor. (Refer to "Low temperature characteristic" on page 94.)

T ₀ Rated torque (Note 7)	N ₀ Rated output Speed	K Rated service life	T _{S1} Allowable acceleration/ deceleration torque	T _{S2} Momentary maximum allowable torque	N _{S0} Allowable Output Speed (Note 1)	Backlash	Lost motion MAX.	Angular transmission error MAX.	Startup efficiency (Typical value)	M _{O1} Allowable moment (Note 4)	M _{O2} Momentary allowable moment (Max.)	W _r Allowable radial load (Note 9)	Reduced value of the inertia moment for the input shaft (Note 5)	I (= $\frac{GD^2}{4}$) Inertia of center gear	Weight
(Nm)	(rpm)	(h)	(Nm)	(Nm)	(r/min)	(arc.min.)	(arc.min.)	(arc.sec.)	(%)	(Nm)	(Nm)	(N)	(kgm ²)	(kgm ²)	(kg)
98	15	6,000	245	490	80	1.0	1.0	70	75	686	1,372	5,755	1.38×10 ⁻⁶	0.678×10 ⁻³	4.6
264.6	15	6,000	662	1,323	60	1.0	1.0	70	80	980	1,960	6,520	0.550×10 ⁻⁴	0.563×10 ⁻³	8.5
490	15	6,000	1,225	Bolt joint 2,450 Through-bolt joint 1,960	50	1.0	1.0	60	75	1,764	3,528	9,428	1.82×10 ⁻⁴	0.363×10 ⁻²	14.6
980	15	6,000	2,450	Bolt joint 4,900 Through-bolt joint 3,430	40	1.0	1.0	50	80	2,450	4,900	11,801	0.475×10 ⁻³	0.953×10 ⁻²	19.5
1,960	15	6,000	4,900	Bolt joint 9,800 Through-bolt joint 7,350	30	1.0	1.0	50	80	8,820	17,640	31,455	1.39×10 ⁻³	1.94×10 ⁻²	55.6
3,136	15	6,000	7,840	15,680	25	1.0	1.0	50	85	20,580	39,200	57,087	0.518×10 ⁻²	0.405×10 ⁻¹	79.5
4,900	15	6,000	12,250	24,500	20	1.0	1.0	50	80	34,300	78,400	82,970	0.996×10 ⁻²	1.014×10 ⁻¹	154

Note: 4. The allowable moment will differ depending on the thrust load. Check the allowable moment diagram (p. 91).

5. The $\frac{GD^2}{4}$ value is a value for a discrete reduction gear, and the $\frac{GD^2}{4}$ for center and input gears is not included. Therefore, refer to the following equation regarding the $\frac{GD^2}{4}$ converted to motor shaft.

$$\frac{GD^2}{4} \text{ of reduction gear unit} + \frac{GD^2}{4} \text{ of center gear} \\ \text{(Number of teeth on large center gear / Number of teeth on input gear)}^2 + \frac{GD^2}{4} \text{ of input gear}$$

6. For the moment rigidity and torsional rigidity, refer to the calculation of tilt angle and the torsion angle (p. 99).

7. The rated torque is the value that produces the rated service life based on operation at the rated output speed; it does not indicate the maximum load. Refer to the "Glossary" (p.81) and the "Product selection flowchart" (p.82).

8. The specifications above are based on Nabtesco evaluation methods; this product should only be used after confirming that it is appropriate for the operating conditions of your system.

9. When a radial load is to be applied to a size within size b, use a value within the allowable radial load.

Design Points

Installation Components

Design of the motor mounting flange

In order to avoid contact with reduction gear components, refer to the sizes indicated in the “External Dimensions” drawings when designing the motor mounting flange.

Note: The size and number of bolts for the motor mounting flange should be determined with the torque and moment taken into consideration, and should be positioned in line with the reduction gear’s case mounting holes.
 After installing the reduction gear, we recommend installing an add/drain grease fitting to enable grease replacement. An installation example is shown below.
 Use the specified tightening torque to uniformly tighten the hexagon socket head cap screws (with corresponding conical spring washers).

To obtain maximum performance from the C series, it is important to optimally design the assembly, installation, lubrication, and sealing. Be sure to read the following precautions before designing the above.

As angular ball bearings are used as the main bearings, design the mating component dimensions according to the dimensions shown in the “External Dimensions” drawings to make sure that the bearing retainer does not come in contact with the motor mounting flange.

Note: Two types of C series are available: bolt clamping output shaft type (refer to pages 40 to 46 for “External Dimensions” drawings, and through bolt clamping output shaft type (refer to pages 47 to 52 for “External Dimensions” drawings excluding RV-500C). Please be sure to specify when ordering.

Assembly accuracy

Design the mounting side components of the C series according to the following. Poor assembly accuracy causes vibration and particularly noise or backlash.

• **Assembly accuracy of RV-10C, 27C, 50C, 100C, 200C, 320C, and 500C**

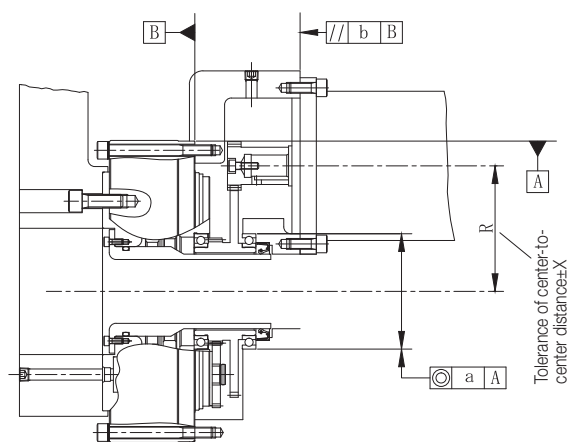

R indicates distance from center of reduction gear to center of motor.

(Unit: mm)

Model	Tolerance of center to-center distance X	Concentricity tolerance a	Tolerance of parallelism b
RV-10C	±0.03	MAX0.03	MAX0.03
RV-27C			
RV-50C			
RV-100C			
RV-200C			
RV-320C			
RV-500C			

Design Points

Installation Components

Installation procedure

- Typical installation examples for reduction gears to be mounted on the mating components are shown below. Be sure to apply the specified amount of the specified grease during assembly. (See page 113 to 114.)
- Seals are required for the mounting surfaces of the center tube and reduction gear. Refer to the O-ring seals shown to make a seal design of the mounting side.
- If O-ring (II) cannot be used due to the structure, apply the appropriate liquid sealant from the table on the right.
- If a seal cannot be formed by applying liquid sealants due to the structure, use O-ring (III) and (IV) on page 55.

Recommended liquid sealant

Manufacturer	Characteristics and applications
ThreeBond 1211 (ThreeBond Co.)	<ul style="list-style-type: none"> • Silicone-based, solventless type • Semi-dry gasket
HermeSeal SS-60F (Nihon Hermetics Co.)	<ul style="list-style-type: none"> • One-part, non-solvent elastic sealant • Metal contact side (flange surface) seal • Any product basically equivalent to ThreeBond 1211
Loctite 515 (Henkel)	<ul style="list-style-type: none"> • Anaerobic flange sealant • Metal contact side (flange surface) seal

Notes 1. Do not use these sealants for copper material or copper alloy material.
2. If these sealants need to be used under special conditions such as concentrated alkali, pressurized steam, etc., please contact Nabtesco.

•Assembly example of center tube

The center tube is used to protect the cable which runs through the hollow section and to seal grease filled in the reduction gear. The following figure shows the assembly of the center tube as a reference example.

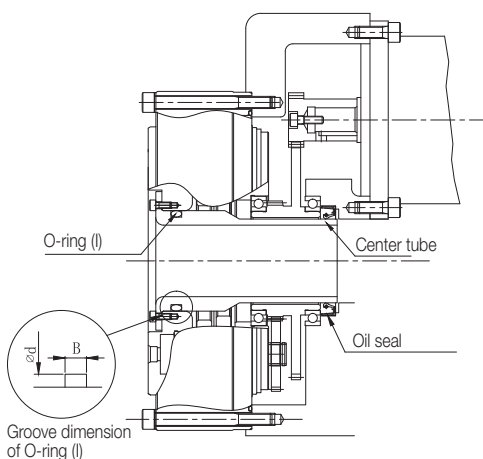

Dimensions of O-ring (I) seal (for reference)

		RV-10C	RV-27C	RV-50C
Dimensions	O-ring			
	ID number	CO 0625	CO 0634	CO 0643
	Wire dia.	ø 2.4 ±0.07	←	ø 3.5 ±0.1
Groove dimensions	I. D.	ø 29.7	ø 42.2	ø 59.6
	I. D.: d	ø 30.2 $^{0}_{-0.08}$	ø 43.2 $^{0}_{-0.08}$	ø 60.3 $^{0}_{-0.10}$
	Width: B	3.2 $^{+0.25}_{0}$	←	4.7 $^{+0.25}_{0}$

(Unit: mm)

		RV-100C	RV-200C	RV-320C	RV-500C
Dimensions	O-ring				
	ID number	S70	G95	G135	G145
	Wire dia.	ø 2.0 ±0.1	ø 3.1 ±0.1	←	←
Groove dimensions	I. D.	ø 69.5	ø 94.4	ø 134.4	ø 144.4
	I. D.: d	ø 70.0 $^{0}_{-0.05}$	ø 95.0 $^{0}_{-0.10}$	ø 135.0 $^{0}_{-0.08}$	ø 145.0 $^{0}_{-0.10}$
	Width: B	2.7 $^{+0.25}_{0}$	4.1 $^{+0.25}_{0}$	←	←

•Assembly example with the output shaft bolt clamping type (RV-10C, 27C, 50C, 100C, 200C, 320C, 500C)

If center tube, oil seal and O-ring (I) are used together, the seal on the mounting surface of output shaft side is not required.

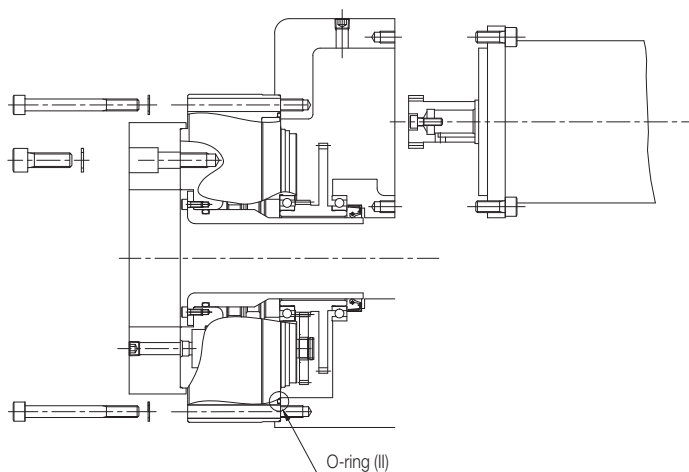

O-ring (II)

	Applicable O-ring
RV-10C	AS568-048
RV-27C	AS568-163
RV-50C	AS568-169
RV-100C	AS568-173
RV-200C	AS568-277
RV-320C	AS568-281
RV-500C	G460

The O-ring (II) can be applied to both bolt clamping and through-bolt clamping output shaft types.

•Assembly example of through-bolt clamping output shaft type
(RV-27C, 50C, 100C and 200C)

The O-ring groove is provided at the end face of output shaft of the reduction gear. Use O-rings as shown below.

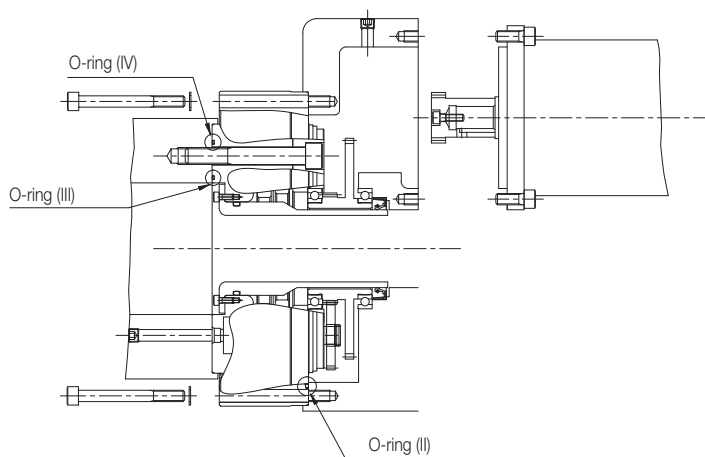

	Applicable O-ring (III)	Applicable O-ring (IV)
RV-27C	S75	S120
RV-50C	S100	S150
RV-100C	G115	AS568-165
RV-200C	S150	AS568-271

•Assembly example of through-bolt clamping output shaft type
(RV-10C and 320C)

Provide the O-ring groove on the counterpart component. Dimensions of O-rings are shown below for reference.

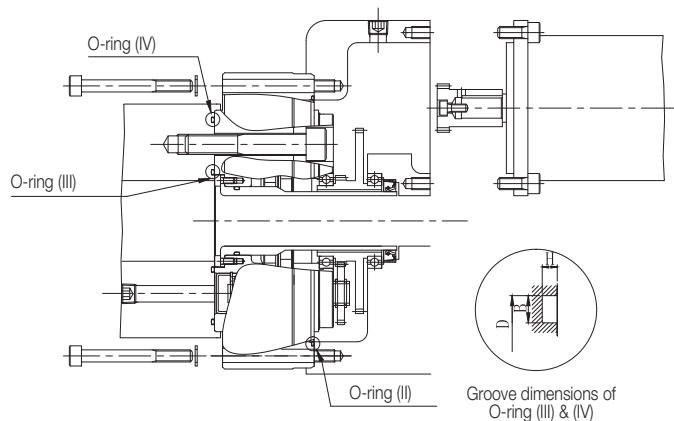

O-ring(III) seal dimensions (for reference) (Unit: mm)

		RV-10C	RV-320C
Dimensions	O-ring	AS568-032	G210
	Groove size		
	Wire dia.	$\varnothing 1.78 \pm 0.07$	$\varnothing 5.7 \pm 0.13$
	I. D.	$\varnothing 47.35 \pm 0.38$	$\varnothing 209.3$
	O. D.: D	$\varnothing 51.0 \begin{smallmatrix} +0.05 \\ 0 \end{smallmatrix}$	$\varnothing 220.0 \begin{smallmatrix} +0.1 \\ 0 \end{smallmatrix}$
	Depth: H	1.27 ± 0.05	5.5 ± 0.05
	Width: B	$2.39 \begin{smallmatrix} +0.25 \\ 0 \end{smallmatrix}$	$7.5 \begin{smallmatrix} +0.25 \\ 0 \end{smallmatrix}$

O-ring(IV) seal dimensions (for reference) (Unit: mm)

		RV-10C	RV-320C
Dimensions	O-ring	S100	G290
	Groove size		
	Wire dia.	$\varnothing 2.0 \pm 0.1$	$\varnothing 5.7 \pm 0.13$
	I. D.	$\varnothing 99.5 \pm 0.4$	$\varnothing 289.3$
	O. D.: D	$\varnothing 103.0 \begin{smallmatrix} +0.05 \\ 0 \end{smallmatrix}$	$\varnothing 300.0 \begin{smallmatrix} +0.1 \\ 0 \end{smallmatrix}$
	Depth: H	$1.5 \begin{smallmatrix} 0 \\ -0.1 \end{smallmatrix}$	5.5 ± 0.05
	Width: B	$2.7 \begin{smallmatrix} +0.25 \\ 0 \end{smallmatrix}$	$7.5 \begin{smallmatrix} +0.25 \\ 0 \end{smallmatrix}$

Note) The S type ID number is the manufacturer's own standard.

Precision Reduction Gear RV™ *Original* series

Model Codes

Explanation of codes

•When placing an order or making an inquiry, please use the following codes to specify the appropriate model.

RV - **60** - **121** - **A** - **T**

Model code	Frame number	Series code	Ratio code	Input gear code Input spline code	Output shaft clamp code
RV	15	No code: Standard type (no main bearing)	57, 81, 105, 121, 141	A: Standard gear A B: Standard gear B Z: No gear	B: Bolt-clamping output shaft type T: Through-bolt clamping output shaft type
	30		57, 81, 105, 121, 153		
	60		57, 81, 101, 121, 153		
	160		81, 101, 129, 145, 171		
	320		81, 101, 118.5, 129, 141, 171, 185		
	450		81, 101, 118.5, 129, 154.8, 171, 192.4		
	550		123, 141, 163.5, 192.4		

Rating Table

Output speed (rpm)				5	10	15	20	25	30	40	50	60
Model	Ratio code	R Speed ratio		Output torque (Nm) / input capacity (kW)								
		Shaft rotation	Case rotation									
RV-15	57	57	56	191 / 0.13	155 / 0.22	137 / 0.29	125 / 0.35	118 / 0.41	112 / 0.49	102 / 0.57	96 / 0.67	91 / 0.76
	81	81	80									
	105	105	104									
	121	121	120									
	141	141	140									
RV-30	57	57	56	464 / 0.32	376 / 0.53	333 / 0.70	306 / 0.85	286 / 1.00	270 / 1.13	248 / 1.39	232 / 1.62	
	81	81	80									
	105	105	104									
	121	121	120									
	153	153	152									
RV-60	57	57	56	886 / 0.62	719 / 1.00	637 / 1.33	584 / 1.63	547 / 1.91	517 / 2.17	474 / 2.65		
	81	81	80									
	101	101	100									
	121	121	120									
	153	153	152									
RV-160	81	81	80	2,176 / 1.52	1,774 / 2.48	1,568 / 3.28	1,441 / 4.02	1,343 / 4.69	1,274 / 5.34			
	101	101	100									
	129	129	128									
	145	145	144									
	171	171	170									
RV-320	81	81	80	4,361 / 3.04	3,538 / 4.94	3,136 / 6.57	2,881 / 8.05	2,695 / 9.41	2,548 / 10.7			
	101	101	100									
	118.5	118.5	117.5									
	129	129	128									
	141	141	140									
	171	171	170									
RV-450	81	81	80	6,135 / 4.28	4,978 / 6.95	4,410 / 9.24	4,047 / 11.3	3,783 / 13.2				
	101	101	100									
	118.5	118.5	117.5									
	129	129	128									
	154.8	2013/13	2000/13									
	171	171	170									
RV-550	123	123	122	7,497 / 5.23	6,086 / 8.50	5,390 / 11.29	4,949 / 13.82					
	141	141	140									
	163.5	163.5	162.5									
	192.4	1347/7	1340/7									

Note: 1. The allowable output speed will differ depending upon the duty ratio, load, and ambient temperature. Contact us regarding use above the allowable output speed Ns1.

2. The input capacity (kW) is calculated according to the following calculation formula:

$$\text{Input capacity (kW)} = \frac{2\pi \cdot N \cdot T}{60 \cdot \frac{\eta}{100} \cdot 10^3}$$

N: Output speed (rpm)
T: Output torque (Nm)
η = 75: Reduction gear efficiency (%)

Note: The input capacity is a reference value.

3. When the reduction gear is used at low temperatures, there will be a larger no-load running torque. Note this characteristic when selecting a motor. (Refer to "Low temperature characteristic" on page 95.)

T ₀ Rated torque (Note 7)	N ₀ Rated output Speed	K Rated service life	T _{S1} Allowable acceleration/ deceleration torque	T _{S2} Momentary maximum allowable torque	N _{S0} Maximum allowable output speed (Note 1)	Backlash	Lost motion MAX.	Angular transmission error MAX.	Startup efficiency (Typical value)	I (= $\frac{60^2}{4}$) Reduced value of the inertia moment for the input shaft (Note 4)	Weight
(Nm)	(rpm)	(h)	(Nm)	(Nm)	(r/min)	(arc.min.)	(arc.min.)	(arc.sec.)	(%)	(kgm ²)	(kg)
137	15	6,000	274	686	60	1.0	1.0	70	75	0.075×10 ⁻⁴	3.6
										0.0488×10 ⁻⁴	
										0.0355×10 ⁻⁴	
										0.0295×10 ⁻⁴	
333	15	6,000	833	1,666	50	1.0	1.0	60	85	0.2323×10 ⁻⁴	6.2
										0.168×10 ⁻⁴	
										0.128×10 ⁻⁴	
										0.109×10 ⁻⁴	
637	15	6,000	1,592	3,185	40	1.0	1.0	50	85	0.7312×10 ⁻⁴	9.7
										0.513×10 ⁻⁴	
										0.404×10 ⁻⁴	
										0.328×10 ⁻⁴	
1,568	15	6,000	3,920	6,615	45	1.0	1.0	50	85	1.963×10 ⁻⁴	19.5
										1.505×10 ⁻⁴	
										1.105×10 ⁻⁴	
										0.903×10 ⁻⁴	
3,136	15	6,000	7,840	12,250	35	1.0	1.0	50	80	0.523×10 ⁻³	34
										0.400×10 ⁻³	
										0.328×10 ⁻³	
										0.295×10 ⁻³	
4,410	15	6,000	11,025	18,620	25	1.0	1.0	50	85	0.263×10 ⁻³	47
										2.005×10 ⁻⁴	
										1.793×10 ⁻⁴	
										0.893×10 ⁻³	
5,390	15	6,000	13,475	26,950	20	1.0	1.0	50	75	0.695×10 ⁻³	72
										0.575×10 ⁻³	
										0.518×10 ⁻³	
										0.408×10 ⁻³	
										0.358×10 ⁻³	
										0.303×10 ⁻³	
										1.178×10 ⁻³	
										0.994×10 ⁻³	
										0.820×10 ⁻³	
										0.655×10 ⁻³	

Note: 4. The inertia moment value is for the reduction gear. It does not include the inertia moment for the input gear.

5. For the torsional rigidity, refer to the calculation of tilt angle and the torsion angle (p. 99).

6. The rated torque is the value that produces the rated service life based on operation at the rated output speed; it does not indicate the maximum load. Refer to the "Glossary" (p.81) and the "Product selection flowchart" (p.82).

7. Contact us regarding speed ratios other than those listed above.

8. The specifications above are based on Nabtesco evaluation methods; this product should only be used after confirming that it is appropriate for the operating conditions of your system.

Design Points

Installation Components

Design of the motor mounting flange

In order to avoid contact with reduction gear components, refer to the sizes indicated in the “External Dimensions” drawings when designing the motor mounting flange.

Note: The size and number of bolts for the motor mounting flange should be determined with the torque and moment taken into consideration, and should be positioned in line with the reduction gear’s case mounting holes.

After installing the reduction gear, we recommend installing an add/drain grease fitting to enable grease replacement. An installation example is shown below.

Use the specified tightening torque to uniformly tighten the hexagon socket head cap screws (with corresponding conical spring washers).

Since the Original series is designed to be an integral part of the equipment, make sure that external thrust or radial loads are not applied to it. When aluminum is used in the structure housing the reduction gear, the clamping force for fixing the bolts may be restricted, depending on the conditions, thus resulting in problems with clamping strength. Study and consider this point thoroughly when designing under such circumstances. In order to achieve maximum performance of the Original series, assembly accuracy, lubrication and sealing are especially important. Read the following carefully before designing.

Assembly accuracy

Design the assembly side of the reduction gear to the following accuracy. (The following figure shows the reduction gear used for shaft revolution. Design it to the same accuracy when using it for case revolution.) Poor accuracy on the assembly side causes vibration or uneven torque in particular.

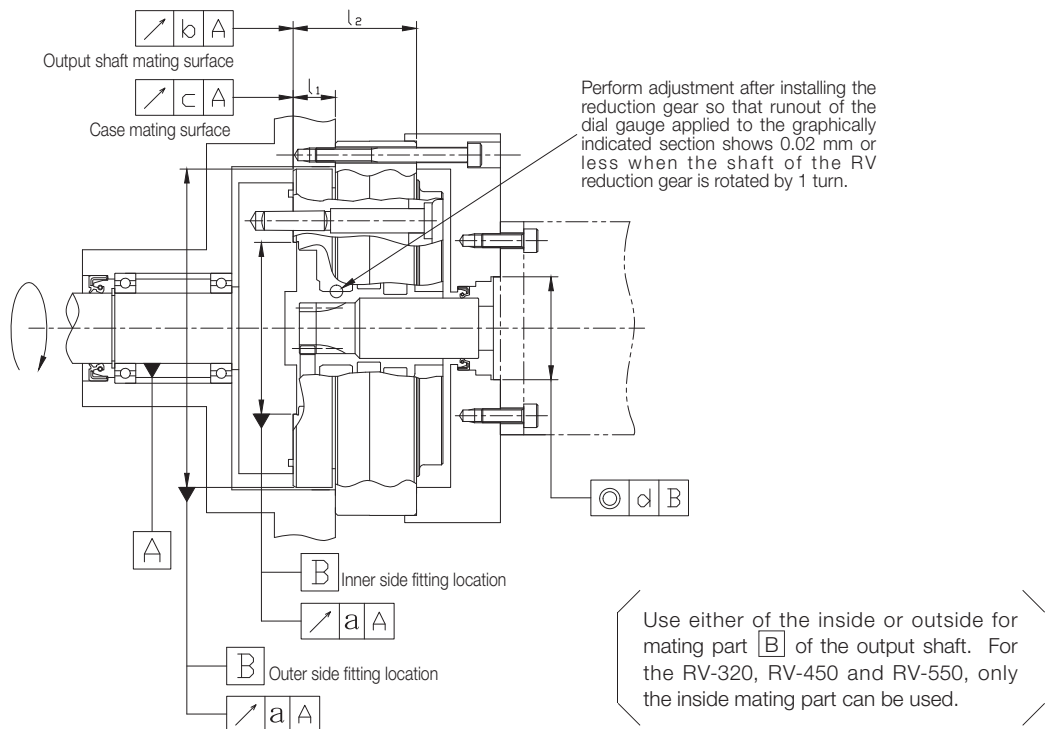

Model	Accuracy	Circumferential deflection tolerance Max. a	Circumferential deflection tolerance Max. b	Circumferential deflection tolerance Max. c	Tolerance for concentricity Max. d	Size accuracy for assembly	
						l_1	l_2
RV-15		0.02	0.02	0.02	0.05	16±0.5	48 ±0.5
RV-30		0.02	0.02	0.02	0.05	22±0.5	56 ±0.5
RV-60		0.05	0.03	0.03	0.05	19±0.5	61 ±0.5
RV-160		0.05	0.03	0.03	0.05	27±1.0	79 ±1.0
RV-320		0.05	0.03	0.05	0.05	33±1.0	96 ±1.0
RV-450		0.05	0.03	0.05	0.05	35±1.0	107.5±1.0
RV-550		0.05	0.03	0.05	0.05	41±1.0	123 ±1.0

Installation

•Reduction gear mounting holes

	Case	Shaft
I	Through-hole and pin hole	Through-hole and pin hole (Through-hole for RV-15 and RV-30)
II	Threaded hole and pin hole	

- Notes
1. Select method I or II so as to meet your requirements.
 2. When using pins additionally, refer to Transmission Torque (page 100) and "External Dimensions" (page 60 to 73).

•Fitting of reduction gear

Through-holes

Shaft side : Provide an internal or external mating part.
Case side : Do not provide a mating part on the case side except when it is used as a motor mounting flange.

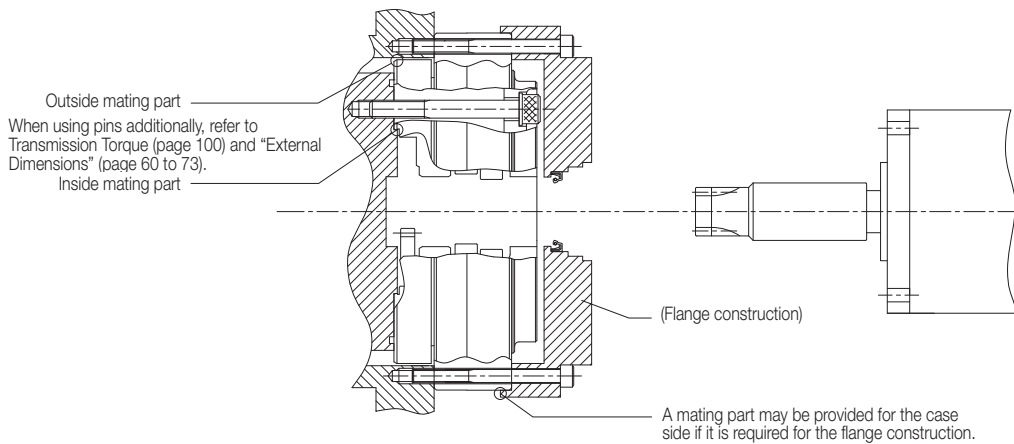

Tapped holes

Shaft side : Provide an internal or external mating part.
Case side : Do not provide a mating part on the case side

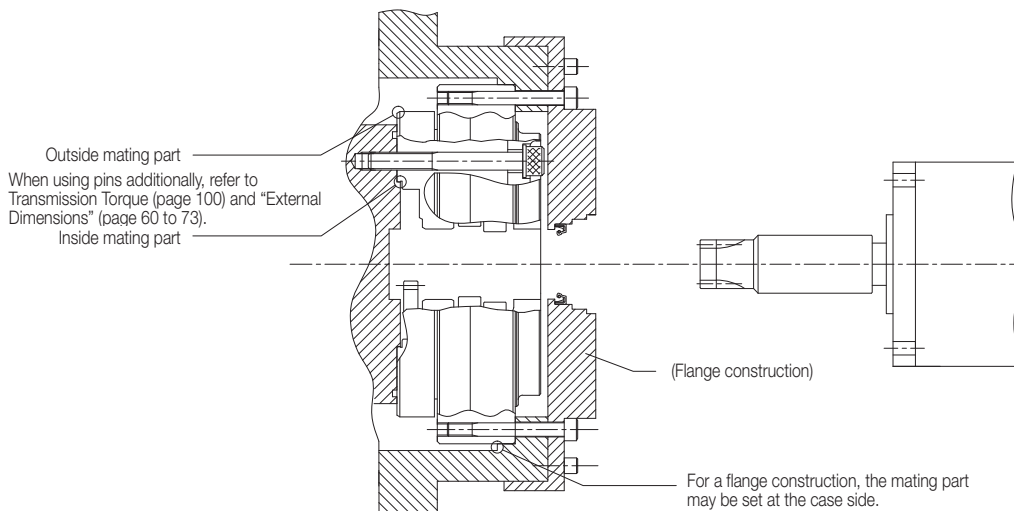

Note : In the reduction gear, there is a slight difference in the concentricity between the shaft side and the case side. If a mating part is provided for both the shaft and case sides, the shaft may rotate eccentrically to the case, causing vibration. Do not provide a mating part on the case side. To assemble the reduction gear, first fasten the shaft side, with the case set freely, then fasten the case from the rear.

Design Points

Installation Components

Installation procedure

- Typical installation examples for reduction gears to be mounted on the mating components are shown below. Be sure to apply the specified amount of the specified grease during assembly. (See page 111 to 112)
- Refer to the O-ring seals shown to make a seal design of the mounting side. Refer to the O-ring seal installation illustrated.
- If an O-ring cannot be used due to the structure, use the Gasket sealant from the table on the right.
- Use either the outside or inside mating part for the shaft.
- If an O-ring cannot be used due to the structure, use the liquid sealants from the table on the right.

Recommended gasket sealant

Manufacturer	Characteristics and applications
ThreeBond 1211 (ThreeBond Co.)	<ul style="list-style-type: none"> • Silicone-based, solventless type • Semi-dry gasket
HermeSeal SS-60F (Nihon Hermetics Co.)	<ul style="list-style-type: none"> • One-part, non-solvent elastic sealant • Metal contact side (flange surface) seal • Any product basically equivalent to ThreeBond 1211
Loctite 515 (Henkel)	<ul style="list-style-type: none"> • Anaerobic flange sealant • Metal contact side (flange surface) seal

- Notes
1. Do not use these sealants for copper material or copper alloy material.
 2. If these sealants need to be used under special conditions such as concentrated alkali, pressurized steam, etc., please consult Nabtesco.

Installation of RV-15, RV-30

•With two crankshafts

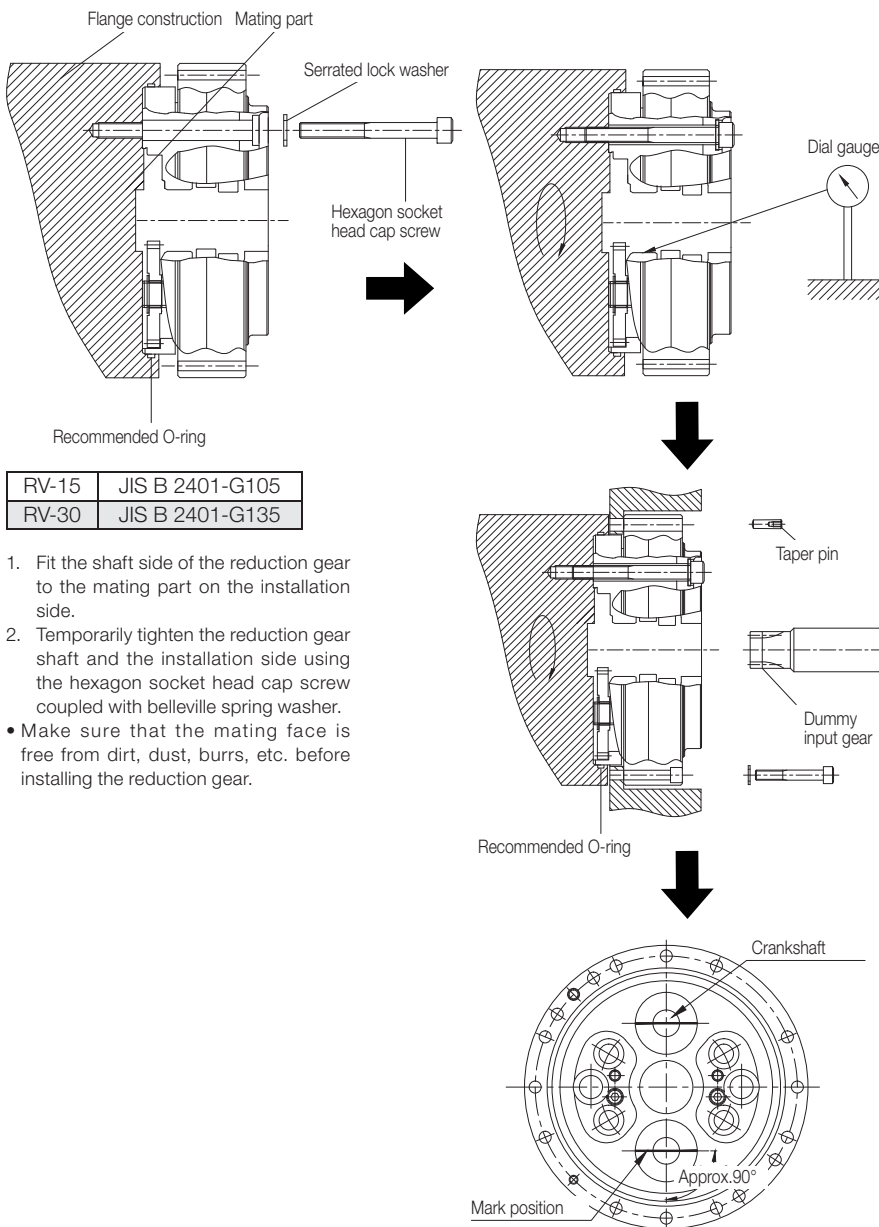

RV-15	JIS B 2401-G105
RV-30	JIS B 2401-G135

1. Fit the shaft side of the reduction gear to the mating part on the installation side.
 2. Temporarily tighten the reduction gear shaft and the installation side using the hexagon socket head cap screw coupled with belleville spring washer.
- Make sure that the mating face is free from dirt, dust, burrs, etc. before installing the reduction gear.

3. Check the reduction gear for assembly accuracy using a dial gauge.

- Turn the reduction gear once on the installation side (output shaft side), and check the dial gauge for run-out. In the case of precision control in which vibration is strictly limited, ensure that the run-out on the gauge is 20 μm or less.
 - When employing case revolution, turn the reduction gear on the dial gauge side for measurement.
4. Tighten the hexagon socket head cap screw to the specified torque.
- Recheck the dial gauge for run-out.

5. Turn the output shaft until the set hole of the case matches the set hole of the body. Temporarily tighten the case using the hexagon socket head cap screw with the belleville spring washer.

- The case may be turned with the input gear or dummy input gear.
6. Make sure that the reduction gear is turned by a moderate torque while adjusting the position of the temporary tightening bolt. Finally, tighten the hexagon socket head cap screw to the specified torque.

- Never tighten the hexagon socket head cap screw before adjusting the reduction gear. Otherwise, the gap between the shaft and case may become uneven, thus causing an uneven torque.
- If a single spur gear of the reduction gear is turned by hand, the spur gear encounters great resistance at two points because of a positional relation of crankshaft phase with RV gear phase. However, this causes no problem.

7. Turn the reduction gear until the mark on the crankshaft comes to the position illustrated.

8. When using the additional pin, ream the pin hole with a tapered reamer and drive the pin.

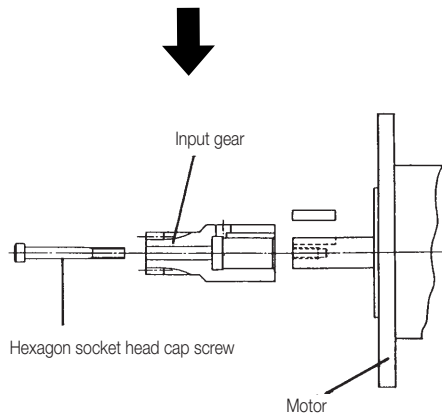

9. Assemble the input gear with the motor shaft.
 - The left figure shows that the motor output shaft is straight and female threaded. For other specifications, refer to "Design of the motor mounting area" (page 104 to 106).
10. Supply a lubricant (grease).
 - For the quantity of lubricant, refer to "Lubricant" (page 111 to 112).

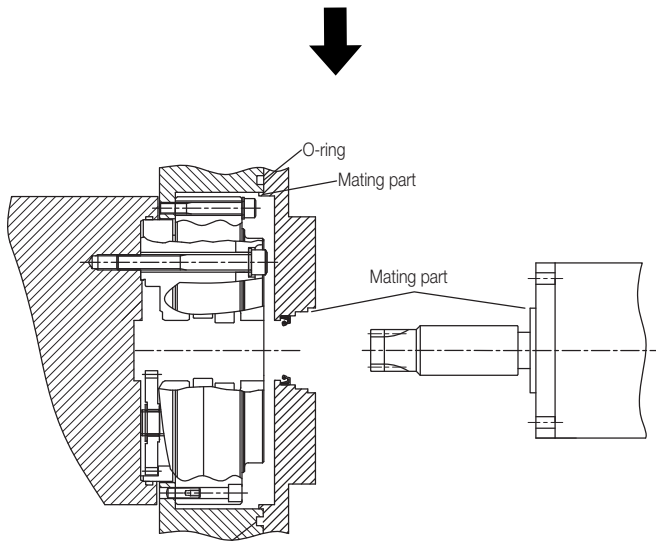

O-ring groove: For details, refer to "External Dimensions" on pages 60 to 73.

11. Insert the motor shaft into the reduction gear, with the motor shaft axis in alignment with the center axis of the reduction gear.
 - When inserting the motor shaft, check to make certain that the motor flange face comes into close contact with the mating face of the reduction gear, with no inclination. Do not tighten the motor mounting bolt without checking the close contact.
 - If the motor flange face is inclined, the input gear may be out of position (refer to 4. "Precautions for assembling the input gear" in "Precautions for Installing the Precision Reduction Gear RV™" included with the reduction gear). Match the mark of the crankshaft with the mark of the motor shaft once again, and insert the motor shaft.
 - Crankshaft markings are for proper assembly of the input gear. If the input gear is installed in the wrong place, damage to the servomotor shafts, input gears and spur gears may result.

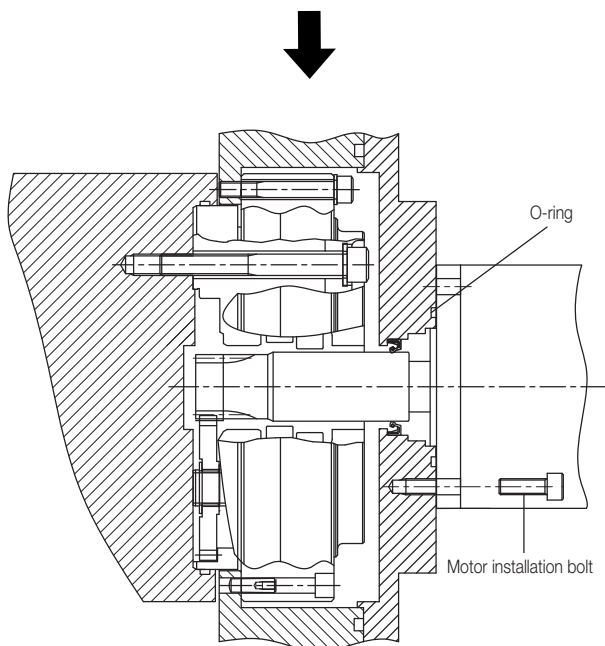

12. Fasten the motor to the case using the motor flange mounting bolts.

Design Points

Installation Components

Installation of RV-60 to RV-550

•With three crankshafts

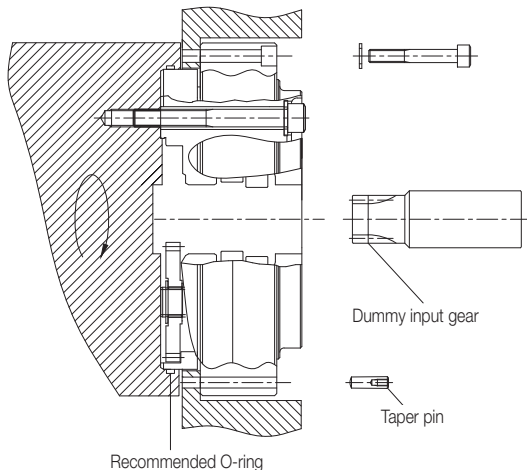
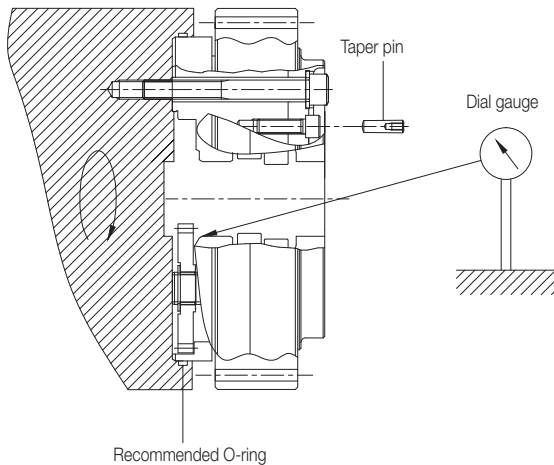
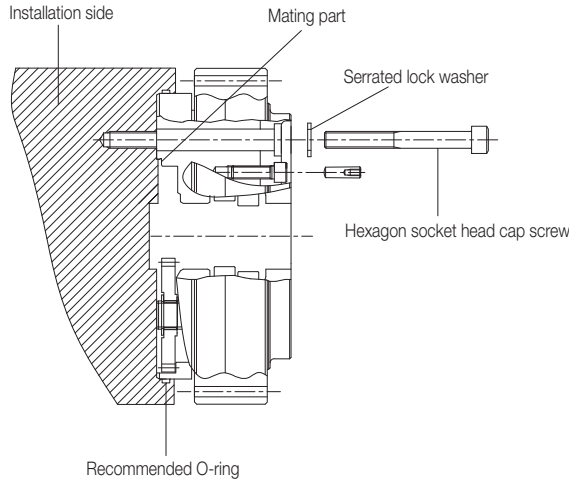

1. Align the shaft side of the reduction gear with the mating part of the mounting side before assembly.
2. Temporarily tighten the shaft part of the reduction gear with the mated body using the hexagon socket head cap screw with the belleville spring washer.
- Make sure that the mating face is free from dirt, burrs, etc. before installing the RV reduction gear.

RV-60	AS568-163
RV-160	AS568-265
RV-320	AS568-271
RV-450	AS568-275

3. Check the reduction gear for assembly accuracy using a dial gauge.
 - Turn the reduction gear once on the installation side (output shaft side), and read the dial gauge for run-out. In the case of precision control in which vibration is strictly limited, ensure that the run-out on the gauge is 20 μ m or less.
 - When employing case revolution, turn the dial gauge side for measurement.
4. Finally, tighten the hexagon socket head cap screw to the specified torque.
 - Recheck the dial gauge for run-out.
5. When using the additional pin, ream the pin hole with a tapered reamer before driving the pin.

6. Turn the output shaft until the set hole of the case matches the set hole of the mated body. Temporarily tighten the case using the hexagon socket head cap screw fitted with belleville spring washer.
 - The case may be turned with the input gear or dummy input gear.
7. Make sure that the reduction gear is turned by a moderate torque while adjusting the temporary tightening bolt. Finally tighten the hexagon socket head cap screw to the specified torque.
 - Never tighten the hexagon socket head cap screw before adjusting the reduction gear. Otherwise, the gap between the shaft and case may become uneven, thus causing an uneven torque.

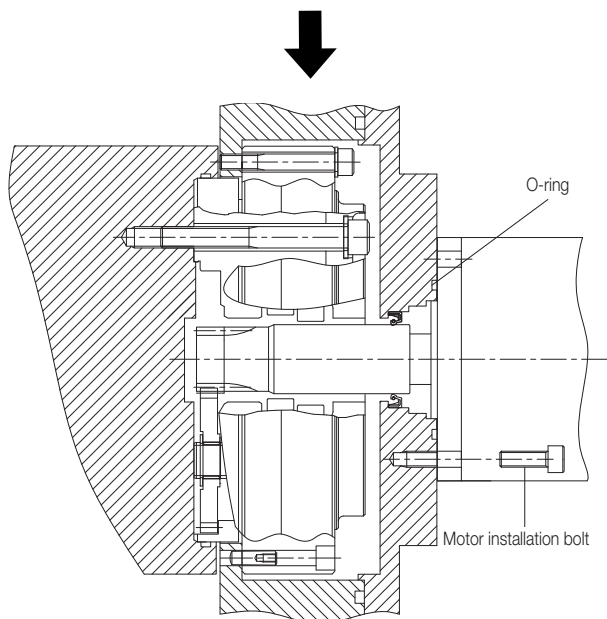
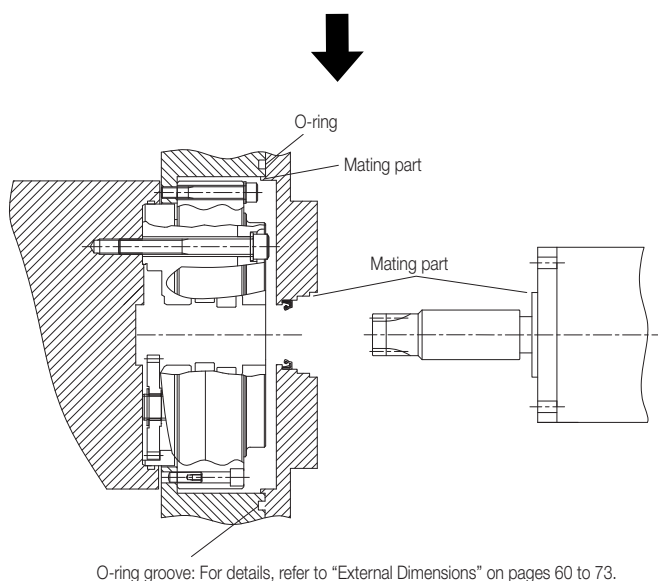
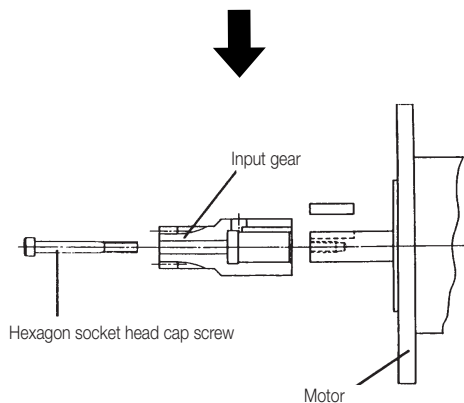

8. When using the additional pin, ream the pin hole with a tapered reamer then drive the pin.
9. Assemble the input gear in the motor shaft.
 - The left figure shows that the motor output shaft is straight and female threaded. For other specifications, see the installation example (section 6.5). Refer to "Design of the motor mounting area" (page 104 to 106).

10. Supply a lubricant (grease).
 - For the quantity of lubricant, refer to "Lubricant" (page 111 to 112).
11. Insert the motor shaft into the reduction gear, with the motor shaft axis in alignment with the center axis of the reduction gear.
 - When inserting the motor shaft, check to make certain that the motor flange face comes into close contact with the mating face of the reduction gear, with no inclination.
 - If the input gear is not in alignment with the spur gear, turn the motor shaft a little in the circumferential direction to insert it.

RV-60	AS568-165
RV-160	With no O-ring groove
RV-320	AS568-178
RV-450	AS568-276
RV-550	*No. 3.5-312

* O-rings for RV-550 are of a special specification. Contact us regarding purchase of these O-rings.

12. Fasten the motor to the case using the motor installation bolts.

Considering the use of Precision Reduction Gear RV™

This product features high precision and high rigidity, however, it is necessary to strictly comply with various restrictions and make appropriate to maximize the product's features. Please read this technical document thoroughly and select and adopt an appropriate model based on the actual operating environment, method, and conditions at your facility.

Export

- When this product is exported from Japan, it may be subject to the export regulations provided in the "Foreign Exchange Order and Export Trade Control Order". Be sure to take sufficient precautions and perform the required export procedures in advance if the final operating party is related to the military or the product is to be used in the manufacture of weapons, etc.

Application

- If failure or malfunction of the product may directly endanger human life or if it is used in units which may injure the human body (atomic energy facilities, space equipment, transportation equipment, medical equipment, safety units, etc.), examination of individual situations is required. Contact our agent or nearest business office in such a case.

Safety measures

- Although this product has been manufactured under strict quality control, a mistake in operation or misuse can result in breakdown or damage, or an accident resulting in injury or death. Be sure to take all appropriate safety measures, such as the installation of independent safeguards.

Product specifications indicated in this catalog

- The specifications indicated in this catalog are based on Nabtesco evaluation methods. This product should only be used after confirming that it is appropriate for the operating conditions of your system.

Operating environment

Use the reduction gear under the following environment:

- Location where the ambient temperature is between -10°C to 40°C.
- Location where the humidity is less than 85% and no condensation occurs.
- Location where the altitude is less than 1000 m.
- Well-ventilated location

Do not install the reduction gear at the following locations.

- Location where a lot of dust is collected.
- Outdoors that can be directly affected by wind and rain
- Location near the environment that contains combustible, explosive, or corrosive gases and flammable materials.
- Location that is heated due to heat transfer and radiation from peripherals and direct sun.
- Location where the performance of the motor can be affected by magnetic fields or vibration.

Note 1: If the required operating environment cannot be established/met, contact us in advance.

2: When using the reduction gear under special conditions (clean room, equipment for food, concentrated alkali, high-pressure steam, etc.), contact our agent or nearest business office in advance.

Maintenance

- The standard replacement time for lubricant is 20,000 hours. However, when operation involves a reduction gear surface temperature above 40°C, the state of degradation of the lubricant should be checked in advance of that and the grease replaced earlier as necessary.

Reduction gear temperature

- When the reduction gear is used under high load and at a high duty ratio, it may overheat and the surface temperature may exceed the allowable temperature. Be aware of conditions so that the surface temperature of the reduction gear does not exceed 60°C while it is in operation. There is a possibility of damage (to the product) if the surface temperature exceeds 60°C.

Reduction gear output rotation angle

- When the range of the rotation angle is small (10° degrees or less), the service life of the reduction gear may be reduced due to poor lubrication or the internal parts being subject to a concentrated load.

Note: Contact us in case the rotation angle is 10° degrees or less.

Note: 12 degrees only for the RV-6E.

Manuals

- Safety information and detail product instructions are indicated in the operation manual. The operation manual can be downloaded from the following website.

<http://precision.nabtesco.com/>

Glossary

Rating service life

The lifetime resulting from the operation with the rated torque and the rated output speed is referred to as the "rated service life".

Allowable acceleration/deceleration torque

When the machine starts or stops, the load torque to be applied to the reduction gear is larger than the constant-speed load torque due to the effect of the inertia torque of the rotating part. In such a situation, the allowable torque during acceleration/deceleration is referred to as "allowable acceleration/deceleration torque".

Note: Be careful that the load torque, which is applied at startup and stop, does not exceed the allowable acceleration/deceleration torque.

Momentary maximum allowable torque

A large torque may be applied to the reduction gear due to execution of emergency stop or by an external shock. In such a situation, the allowable value of the momentary applied torque is referred to as "momentary maximum allowable torque".

Note: Be careful that the momentary excessive torque does not exceed the momentary maximum allowable torque.

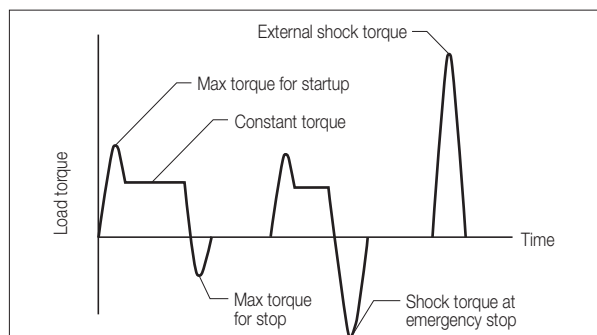

Allowable output speed

The allowable value for the reduction gear's output speed during operation without a load is referred to as the "allowable output speed".

Notes: Depending on the conditions of use (duty ratio, load, ambient temperature), the reduction gear temperature may exceed 60°C even when the speed is under the allowable output speed. In such a case, either take cooling measures or use the reduction gear at a speed that keeps the surface temperature at 60°C or lower.

Duty ratio

The duty ratio is defined as the ratio of the sum total time of acceleration, constant, and deceleration to the cycle time of the reduction gear.

Torsional rigidity, lost motion, backlash

When a torque is applied to the output shaft while the input shaft is fixed, torsion is generated according to the torque value. The torsion can be shown in the hysteresis curves.

The value of b/a is referred to as "torsional rigidity".

The torsion angle at the mid point of the hysteresis curve width within $\pm 3\%$ of the rated torque is referred to as "lost motion".

The torsion angle when the torque indicated by the hysteresis curve is equal to zero is referred to as "backlash".

<Hysteresis curve>

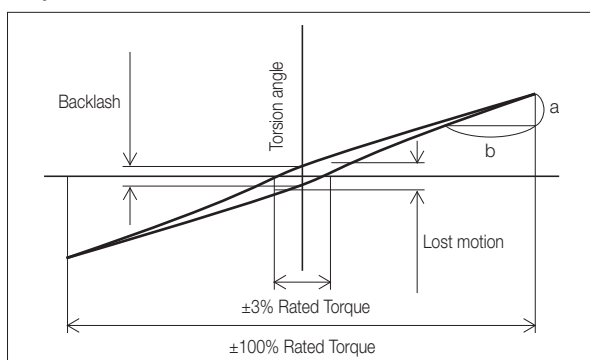

Startup Efficiency

The efficiency of the moment when the reduction gear starts up is referred to as "startup efficiency".

No-load running torque (input shaft)

The torque for the input shaft that is required to run the reduction gear without load is referred to as "no-load running torque".

Allowable Moment and Maximum Thrust Load

The external load moment may be applied to the reduction gear during normal operation. The allowable values of the external moment and the external axial load at this time are each referred to as "allowable moment" and "maximum thrust load".

Angular transmission error

The angular transmission error is defined as the difference between the theoretical output angle of rotation (when there are input instructions for an arbitrary rotation angle) and the actual output angle of rotation.

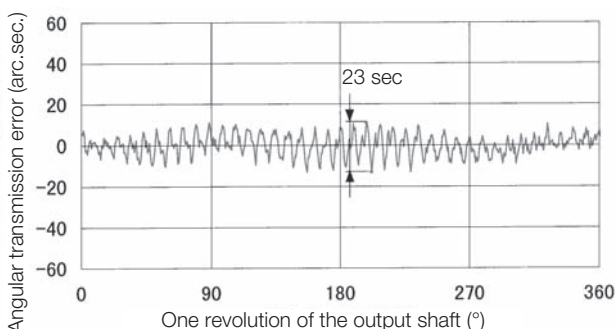

Product Selection Flowchart

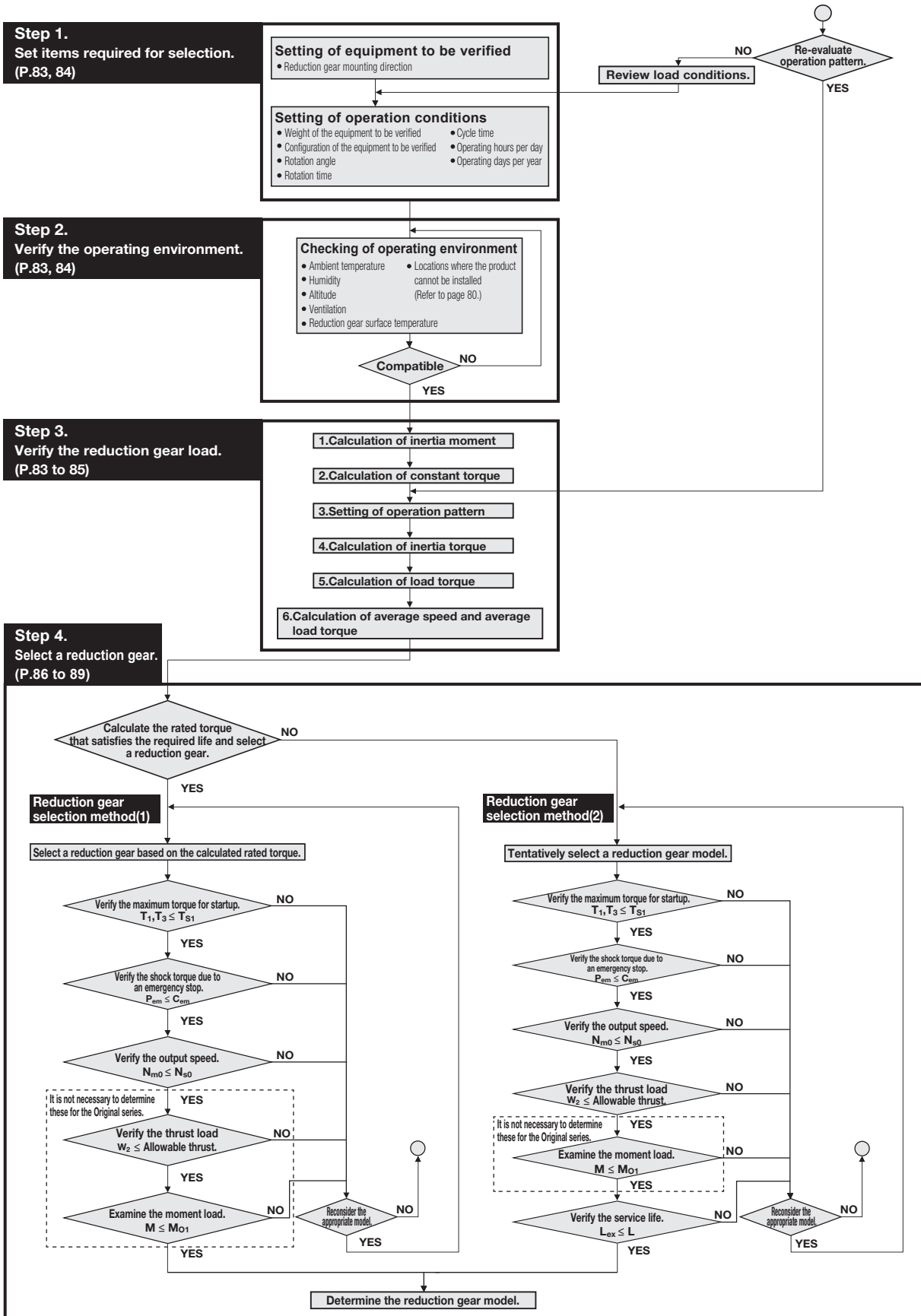

A limitation is imposed on the motor torque value according to the momentary maximum allowable torque of the selected reduction gear. (Refer to page 90)

With horizontal rotational transfer

Step 1. Set the items required for selection.

Setting item	Setting
Reduction gear mounting direction	Vertical shaft installation
Equipment weight to be considered	
W _A ——— Disk weight (kg)	180
W _B ——— Work weight (kg)	20×4 pieces
Equipment configuration to be considered	
D ₁ ——— Disk: D dimension (mm)	1,200
a ——— Work piece: a dimension (mm)	100
b ——— Work piece: b dimension (mm)	300
D ₂ ——— Work piece: P.C.D. (mm)	1,000
Operation conditions	
θ ——— Rotation angle (°)*1	180
[t ₁ +t ₂ +t ₃] ——— Rotation time (s)	2.5
[t ₄] ——— Cycle time (s)	20
Q ₁ ——— Equipment operation hours per day (hours/day)	12
Q ₂ ——— Equipment operation days per year (days/year)	365

*1. When the range of the rotation angle is small (10 degrees or less), the rating life of the reduction gear may be reduced due to poor lubrication or the internal parts being subject to a concentrated load.

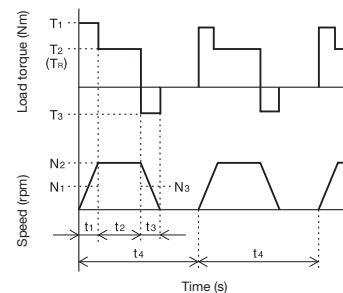
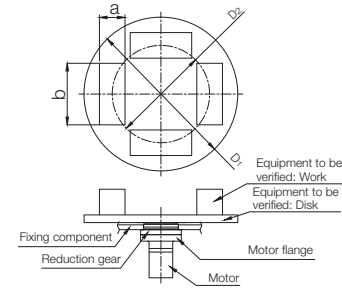

Step 2. Verify the operating environment.

Checkpoint	Standard value
S ₀ ——— Ambient temperature (°C)	-10 to +40
S ₁ ——— Reduction gear surface temperature (°C)	60 or less

Note: Refer to "Operating environment" on p.80 for values other than those listed above.

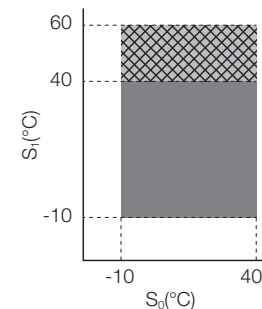

Step 3-1. Examine the reduction gear load

Setting item	Calculation formula	Selection examples
(1) Calculate the inertia moment based the calculation formula on page 52.		
I _R Load inertia moment (kgm ²)	$I_{R1} = \frac{W_A \times \left(\frac{D_1}{2 \times 1,000}\right)^2}{2}$ $I_{R2} = \left[\frac{W_B}{12} \left\{ \left(\frac{a}{1,000}\right)^2 + \left(\frac{b}{1,000}\right)^2 \right\} + W_B \times \left(\frac{D_2}{2 \times 1,000}\right)^2 \right] \times n$ <p>I_{R1} = Disk inertia moment I_{R2} = Work inertia I_R = I_{R1} + I_{R2} n = Number of work pieces</p>	$I_{R1} = \frac{180 \times \left(\frac{1,200}{2 \times 1,000}\right)^2}{2}$ $= 32.4 \text{ (kgm}^2\text{)}$ $I_{R2} = \left[\frac{20}{12} \left\{ \left(\frac{100}{1,000}\right)^2 + \left(\frac{300}{1,000}\right)^2 \right\} + 20 \times \left(\frac{1,000}{2 \times 1,000}\right)^2 \right] \times 4$ $= 20.7 \text{ (kgm}^2\text{)}$ $I_R = 32.4 + 20.7$ $= 53.1 \text{ (kgm}^2\text{)}$
(2) Examine the constant torque.		
T _R Constant torque (Nm)	$T_R = (W_A + W_B) \times 9.8 \times \frac{D_{in}}{2 \times 1,000} \times \mu$ <p>μ = Friction factor Note: Use 0.015 for this example as the load is applied to the bearing of the RD2 precision reduction gear. D_{in} = Rolling diameter: Use the pilot diameter which is almost equivalent to the rolling diameter in this selection calculation. Note: If the reduction gear model is not determined, select the following pilot diameter: Maximum pilot diameter E series = 328 (mm) C series = 520 (mm) Original series = 370 (mm)</p>	$T_R = (180 + 20 \times 4) \times 9.8 \times \frac{328}{2 \times 1,000} \times 0.015$ $= 6.3 \text{ (Nm)}$

Step 3-2: Proceed to p. 85.

Product Selection

Model Code Selection Examples

With vertical rotational transfer

Step 1. Set the items required for selection.

Setting item	Setting
Reduction gear mounting direction	Horizontal shaft installation
Equipment weight to be considered	
W_C — Mounted work weight (kg)	490
Equipment configuration to be considered	
a — a dimension (mm)	500
b — b dimension (mm)	500
R — R dimension (mm)	320
Operation conditions	
θ — Rotation angle (°)*1	90
$[t_1+t_2+t_3]$ — Rotation time (s)	1.5
$[t_4]$ — Cycle time (s)	20
Q_1 — Equipment operation hours per day (hours/day)	24
Q_2 — Equipment operation days per year (days/year)	365

*1. When the range of the rotation angle is small (10 degrees or less), the rating life of the reduction gear may be reduced due to poor lubrication or the internal parts being subject to a concentrated load.

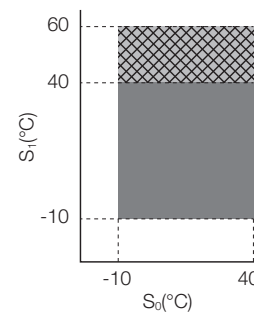
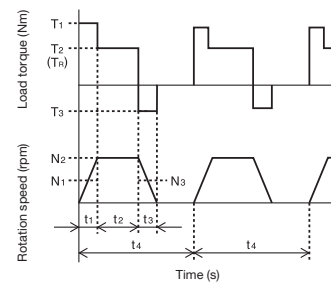
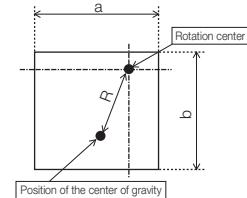
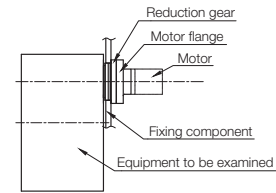

Step 2. Verify the operating environment.

Checkpoint	Standard value
S_0 — Ambient temperature (°C)	-10 to +40
S_1 — Reduction gear surface temperature (°C)	60 or less

Note: Refer to "Operating environment" on p. 80 for values other than those listed above.

Step 3-1. Examine the reduction gear load

Setting item	Calculation formula	Selection examples
(1) Calculate the inertia moment.		
I_R Load inertia moment (kgm ²)	$I_R = \frac{W_C}{12} \times \left[\left(\frac{a}{1,000} \right)^2 + \left(\frac{b}{1,000} \right)^2 \right] + W_C \times \left(\frac{R}{1,000} \right)^2$	$I_R = \frac{490}{12} \times \left[\left(\frac{500}{1,000} \right)^2 + \left(\frac{500}{1,000} \right)^2 \right] + 490 \times \left(\frac{320}{1,000} \right)^2 = 70.6 \text{ (kgm}^2\text{)}$
(2) Examine the constant torque.		
T_R Constant torque (Nm)	$T_R = W_C \times 9.8 \times \frac{R}{1,000}$	$T_R = 490 \times 9.8 \times \frac{320}{1,000} = 1,537 \text{ (Nm)}$

Step 3-2: Proceed to p. 85.

(Refer to "With horizontal rotational transfer" for selection examples.)

Step 3-2. Set items required for selection

Setting item	Calculation formula	Selection examples (With horizontal rotational transfer)
(3) Set the acceleration/deceleration time, constant-speed operation time, and output speed.		
t ₁ — Acceleration time (s)	<ul style="list-style-type: none"> The operation pattern does not need to be verified if it is already set. If the operation pattern has not been determined, use the following formula to calculate the reference operation pattern. $t_1 = t_3 = \text{Rotation} [t_1 + t_2 + t_3] - \frac{\theta}{\left(\frac{N_2}{60} \times 360\right)}$ $t_2 = \text{Rotation} [t_1 + t_2 + t_3] - (t_1 + t_3)$ <p>Note: 1. Assume that t₁ and t₃ are the same. Note: 2. N₂ = 15 rpm if the reduction gear output speed (N₂) is not known. Note: 3. If t₁ and t₃ is less than 0, increase the output speed or extend the rotation time.</p>	Examine the operation pattern using N ₂ = 15 rpm as the reduction gear output speed is unknown. $t_1 = t_3 = 2.5 - \frac{180}{\left(\frac{15}{60} \times 360\right)} = 0.5(\text{s})$ $t_2 = 2.5 - (0.5 + 0.5) = 1.5(\text{s})$ <p>∴ t₁ = t₃ = 0.5(s) t₂ = 1.5(s) N₂ = 15 (rpm)</p>
t ₂ — Constant-speed operation time (s)		
t ₃ — Deceleration time (s)		
N ₂ — Constant speed (rpm)		
N ₁ — Average speed for startup (rpm)	$N_1 = \frac{N_2}{2}$	$N_1 = \frac{15}{2} = 7.5(\text{rpm})$
N ₃ — Average speed for stop (rpm)	$N_3 = \frac{N_2}{2}$	$N_3 = \frac{15}{2} = 7.5(\text{rpm})$
(4) Calculate the inertia torque for acceleration/deceleration.		
T _A — Inertia torque for acceleration (Nm)	$T_A = \left\{ \frac{I_R \times (N_2 - 0)}{t_1} \right\} \times \frac{2\pi}{60}$	$T_A = \left\{ \frac{53.1 \times (15 - 0)}{0.5} \right\} \times \frac{2\pi}{60}$ = 166.8 (Nm)
T _D — Inertia torque for deceleration (Nm)	$T_D = \left\{ \frac{I_R \times (0 - N_2)}{t_3} \right\} \times \frac{2\pi}{60}$	$T_D = \left\{ \frac{53.1 \times (0 - 15)}{0.5} \right\} \times \frac{2\pi}{60}$ = -166.8 (Nm)
(5) Calculate the load torque for acceleration/deceleration.		
T ₁ — Maximum torque for startup (Nm)	$T_1 = T_A + T_R $ T _R : Constant torque With horizontal rotational transfer Refer to page 83 With vertical rotational transfer Refer to page 84	$T_1 = 166.8 + 6.3 $ = 173.1 (Nm)
T ₂ — Constant maximum torque (Nm)	$T_2 = T_R $	$T_2 = 6.3(\text{Nm})$
T ₃ — Maximum torque for stop (Nm)	$T_3 = T_A + T_R $ T _R : Constant torque With horizontal rotational transfer Refer to page 83 With vertical rotational transfer Refer to page 84	$T_3 = -166.8 + 6.3 $ = 160.5 (Nm)
(6)-1 Calculate the average speed.		
N _m — Average speed (rpm)	$N_m = \frac{t_1 \times N_1 + t_2 \times N_2 + t_3 \times N_3}{t_1 + t_2 + t_3}$	$N_m = \frac{0.5 \times 7.5 + 1.5 \times 15 + 0.5 \times 7.5}{0.5 + 1.5 + 0.5}$ = 12 (rpm)
(6)-2 Calculate the average load torque.		
T _m — Average load torque (Nm)	$T_m = \sqrt[10]{\frac{t_1 \times N_1 \times t_1^{\frac{10}{3}} + t_2 \times N_2 \times t_2^{\frac{10}{3}} + t_3 \times N_3 \times t_3^{\frac{10}{3}}}{t_1 \times N_1 + t_2 \times N_2 + t_3 \times N_3}}$	$T_m = \sqrt[10]{\frac{0.5 \times 7.5 \times 173.1^{\frac{10}{3}} + 1.5 \times 15 \times 6.5^{\frac{10}{3}} + 0.5 \times 7.5 \times 160.5^{\frac{10}{3}}}{0.5 \times 7.5 + 1.5 \times 15 + 0.5 \times 7.5}}$ = 110.2 (Nm)

Go to page 86 if the reduction gear model is verified based on the required life.
Go to page 88 if the service life is verified based on the reduction gear model.

Model Code Selection Examples

Step 4. Select a reduction gear

Reduction gear selection method (1) Calculate the required torque based on the load conditions and required life and select a reduction gear.

Setting/verification item	Calculation formula	Selection examples (With horizontal rotational transfer)
(1) Calculate the rated torque for the reduction gear that satisfies the required life.		
L_{ex} Required life (year)	Based on the operation conditions	5 years
Q_{1cy} Number of cycles per day (times)	$Q_{1cy} = \frac{Q_1 \times 60 \times 60}{t_4}$	$Q_{1cy} = \frac{12 \times 60 \times 60}{20}$ = 2,160 (times)
Q_3 Operating hours of reduction gear per day (h)	$Q_3 = \frac{Q_{1cy} \times (t_1 + t_2 + t_3)}{60 \times 60}$	$Q_3 = \frac{2,160 \times (0.5 + 1.5 + 0.5)}{60 \times 60}$ = 1.5 (h)
Q_4 Operating hours of reduction gear per year (h)	$Q_4 = Q_3 \times Q_2$	$Q_4 = 1.5 \times 365$ = 548 (h)
L_{hour} Reduction gear service life (h)	$L_{hour} = Q_4 \times L_{ex}$	$L_{hour} = 548 \times 5$ = 2,740 (h)
$T_{0'}$ Reduction gear rated torque that satisfies the required life (Nm)	$T_{0'} = T_m \times \left(\frac{10}{3}\right) \sqrt{\frac{L_{hour}}{K} \times \frac{N_m}{N_0}}$ K : Reduction gear rated life (h) N_0 : Reduction gear rated output speed (rpm)	$T_{0'} = 110.2 \times \left(\frac{10}{3}\right) \sqrt{\frac{2,740 \times 12}{6,000 \times 15}}$ = 81.5 (Nm)
(2) Tentatively select a reduction gear model based on the calculated rated torque.		
Tentative selection of the reduction gear	Select a reduction gear for which the rated torque of the reduction gear [T_0] ¹ is equal to or greater than the rated torque of the reduction gear that satisfies the required life [$T_{0'}$]. *1 [T_0]: E series: Page 12 to 13 C series: Page 38 to 39 Original series: Page 58 to 59 Refer to the individual rating tables.	RV-20E that meets the following condition is tentatively selected: [T_0] 167 (Nm) ≥ [$T_{0'}$] 81.5 (Nm)
(3) Verify the maximum torque for startup and stop.		
Verification of maximum torque for startup and stop	Check the following conditions: The allowable acceleration/deceleration torque [T_{s1}] ¹ is equal to or greater than the maximum starting torque [T_1] ² and maximum stopping torque [T_3] ² . If the tentatively selected reduction gear is outside of the specifications, change the reduction gear model. *1 [T_{s1}]: E series: Page 12 to 13 C series: Page 38 to 39 Original series: Page 58 to 59 Refer to the individual rating tables. *2 [T_1] and [T_3]: Refer to page 85	[T_{s1}] 412 (Nm) ≥ [T_1] 173.1 (Nm) [T_3] 160.5 (Nm) According to the above conditions, the tentatively selected model should be no problem.
(4) Verify the output speed.		
N_{m0} Average speed per cycle (rpm)	$N_{m0} = \frac{t_1 \times N_1 + t_2 \times N_2 + t_3 \times N_3}{t_4}$	$N_{m0} = \frac{0.5 \times 7.5 + 1.5 \times 15 + 0.5 \times 7.5}{20}$ = 1.5 (rpm)
Verification of output speed	Check the following condition: The allowable output speed [N_{s0}] ¹ is equal to or greater than the average speed per cycle [N_{m0}]. If the tentatively selected reduction gear is outside of the specifications, change the reduction gear model. Contact us regarding use of the model at a speed outside the allowable output speed [N_{s0}] ¹ . Note: The value of [N_{s0}] is the speed at which the case temperature is balanced at 60°C for 30 minutes. *1 [N_{s0}] and [N_{s1}]: E series: Page 12 to 13 C series: Page 38 to 39 Original series: Page 58 to 59 Refer to the individual rating tables.	[N_{s0}] 75 (rpm) ≥ [N_{m0}] 1.5 (rpm) According to the above condition, the tentatively selected model should be no problem.

Reduction gear selection method (1) Calculate the required torque based on the load conditions and required life and select a reduction gear.

Setting/verification item	Calculation formula	Selection examples (With horizontal rotational transfer)																													
(5) Verify the shock torque at the time of an emergency stop.																															
P_{em} ——— Expected number of emergency stop times (times)	Based on the operation conditions.	For example, an emergency stop occurs once a month. [P_{em}] = 1 × 12 × required life (year) [L_{ex}] = 12 × 5 = 60 (times)																													
T_{em} ——— Shock torque due to an emergency stop (Nm)		For example, [T_{em}] = 500 (Nm)																													
N_{em} ——— Speed at the time of an emergency stop (rpm)		For example, [N_{em}] = 15 (rpm)																													
t_{em} ——— Deceleration time at the time of an emergency stop (s)		For example, [t_{em}] = 0.05 (s)																													
Z_4 ——— Number of pins for reduction gear		<table border="1"> <thead> <tr> <th>Model</th> <th>Number of pins (Z)</th> <th>Model</th> <th>Number of pins (Z)</th> <th>Model</th> <th>Number of pins (Z)</th> </tr> </thead> <tbody> <tr> <td>RV-6E</td> <td rowspan="8">40</td> <td>RV-10C</td> <td rowspan="4">52</td> <td>RV-15</td> <td rowspan="8">40</td> </tr> <tr> <td>RV-20E</td> <td>RV-27C</td> <td>RV-30</td> </tr> <tr> <td>RV-40E</td> <td>RV-50C</td> <td>RV-60</td> </tr> <tr> <td>RV-110E</td> <td>RV-100C</td> <td>RV-160</td> </tr> <tr> <td>RV-160E</td> <td>RV-200C</td> <td>RV-320</td> </tr> <tr> <td>RV-320E</td> <td>RV-320C</td> <td>RV-450</td> </tr> <tr> <td>RV-450E</td> <td>RV-500C</td> <td>RV-550</td> </tr> </tbody> </table>	Model	Number of pins (Z)	Model	Number of pins (Z)	Model	Number of pins (Z)	RV-6E	40	RV-10C	52	RV-15	40	RV-20E	RV-27C	RV-30	RV-40E	RV-50C	RV-60	RV-110E	RV-100C	RV-160	RV-160E	RV-200C	RV-320	RV-320E	RV-320C	RV-450	RV-450E	RV-500C
Model	Number of pins (Z)	Model	Number of pins (Z)	Model	Number of pins (Z)																										
RV-6E	40	RV-10C	52	RV-15	40																										
RV-20E		RV-27C		RV-30																											
RV-40E		RV-50C		RV-60																											
RV-110E		RV-100C		RV-160																											
RV-160E		RV-200C	RV-320																												
RV-320E		RV-320C	RV-450																												
RV-450E		RV-500C	RV-550																												
C_{em} ——— Allowable number of shock torque application times		$C_{em} = \frac{775 \times \left(\frac{T_{s2}}{T_{em}} \right)^{\frac{10}{3}}}{Z_4 \times \frac{N_{em}}{60} \times t_{em}}$ <p>Note [T_{s2}]: Momentary maximum allowable torque E series: Page 12 to 13 C series: Page 38 to 39 Original series: Page 58 to 59 Refer to the individual rating tables.</p>	$C_{em} = \frac{775 \times \left(\frac{833}{500} \right)^{\frac{10}{3}}}{40 \times \frac{15}{60} \times 0.05} = 8,497 \text{ (times)}$																												
Verification of shock torque due to an emergency stop	Check the following condition: The allowable shock torque application count [C_{em}] is equal to or greater than the expected emergency stop count [P_{em}] If the tentatively selected reduction gear is outside of the specifications, change the reduction gear model.	[C_{em}] 8,497 ≥ [P_{em}] 60 According to the above condition, the tentatively selected model should be no problem.																													
(6) Verify the thrust load and moment load. (It is not necessary to determine these for the Original series.)																															
W_1 ——— R adial load (N)		0 (N)																													
l ——— Distance to the point of radial load application (mm)		0 (mm)																													
W_2 ——— Thrust load (N)		In this example, $W_2 = W_A + W_B = (180 + 20 \times 4) \times 9.8 = 2,548 \text{ (N)}$ Note W_A, W_B : Refer to page 83.																													
l_2 ——— Distance to the point of thrust load application (mm)		0 (mm) (As the workpiece center is located on the rotation axis)																													
M ——— Moment load (Nm)		RV-20E As dimension $a = 20.1 \text{ (mm)}$ and dimension $b = 113.3 \text{ (mm)}$: $M = \frac{0 \times (0 + 113.3 - 20.1) + 2,548 \times 0}{1,000} = 0 \text{ (Nm)}$																													
Verify the thrust load and moment load	Check that the thrust load and moment load are within the range in the allowable moment diagram on page 91. When radial load W_1 is applied within dimension b , use the reduction gear within the allowable radial load. W_r : Allowable radial load: E series: Page 12 to 13, C series: Page 38 to 39, Original series: Page 58 to 59 Refer to the individual rating tables. If the tentatively selected reduction gear is outside of the specifications, change the reduction gear model.	For this example, Thrust load [W_2] = 2,548 (N) Moment load [M] = 0 (N) As the above values are within the range in the allowable moment diagram, the tentatively selected model should be no problem.																													
Select the reduction gear model that satisfies all the conditions of the above verification items. The actual reduction ratio is determined based on the motor speed, input torque, and inertia moment. Check with the motor manufacturer.	Based on the above verification result, RV-20E is selected.																														

Model Code Selection Examples

Reduction gear selection method (2): Tentatively select a reduction gear model and evaluate the service life.

Setting/verification item	Calculation formula	Selection examples (With horizontal rotational transfer)																														
(1) Tentatively select a desired reduction gear model.																																
Tentative selection of a reduction gear	Tentatively select a desired reduction gear model.	For example, tentatively select RV-20E.																														
(2) Verify the maximum torque for startup and stop.																																
Verification of maximum torque for startup and stop	<p>Check the following conditions: The allowable acceleration/deceleration torque $[T_{s1}]^1$ is equal to or greater than the maximum starting torque $[T_1]^2$ and maximum stopping torque $[T_3]^2$</p> <p>If the tentatively selected reduction gear is outside of the specifications, change the reduction gear model.</p> <p>*1 $[T_{s1}]$: E series: Page 12 to 13, C series: Page 38 to 39, Original series: Page 58 to 59 Refer to the individual rating tables. *2 $[T_1]$ and $[T_3]$: Refer to page 85</p>	<p>$[T_{s1}]$ 412 (Nm) $\geq [T_1]$ 173.1 (Nm) $[T_3]$ 160.5 (Nm)</p> <p>According to the above conditions, the tentatively selected model should be no problem.</p>																														
(3) Verify the output speed.																																
N_{m0} — Average speed per cycle (rpm)	$N_{m0} = \frac{t_1 \times N_1 + t_2 \times N_2 + t_3 \times N_3}{t_4}$	$N_{m0} = \frac{0.5 \times 7.5 + 1.5 \times 15 + 0.5 \times 7.5}{20} = 1.5 \text{ (rpm)}$																														
Verification of output speed	<p>Check the following condition: The allowable output speed $[N_{s1}]^1$ is equal to or greater than the average speed per cycle $[N_{m0}]$</p> <p>If the tentatively selected reduction gear is outside of the specifications, change the reduction gear model. Contact us regarding use of the model at a speed outside the allowable output speed $[N_{s1}]^1$.</p> <p>Note: The value of $[N_{s0}]$ is the speed at which the case temperature is balanced at 60°C for 30 minutes.</p> <p>*1 $[N_{s0}]$ and $[N_{s1}]$: E series: Page 12 to 13, C series: Page 38 to 39, Original series: Page 58 to 59 Refer to the individual rating tables.</p>	<p>$[N_{s0}]$ 75 (rpm) $\geq [N_{m0}]$ 1.5 (rpm)</p> <p>According to the above condition, the tentatively selected model should be no problem.</p>																														
(4) Verify the shock torque at the time of an emergency stop.																																
P_{em} — Expected number of emergency stop times (times)	Based on the operation conditions.	For example, an emergency stop occurs once a month. $[P_{em}] = 1 \times 12 \times \text{required life (year)} [L_{ex}] = 12 \times 5 = 60 \text{ (times)}$																														
T_{em} — Shock torque due to an emergency stop (Nm)		For example, $[T_{em}] = 500 \text{ (Nm)}$																														
N_{em} — Speed at the time of an emergency stop (rpm)		For example, $[N_{em}] = 15 \text{ (rpm)}$																														
t_{em} — Deceleration time at the time of an emergency stop (s)		For example, $[t_{em}] = 0.05 \text{ (s)}$																														
Z_4 — Number of pins for reduction gear		<table border="1"> <thead> <tr> <th>Model</th> <th>Number of pins (Z)</th> <th>Model</th> <th>Number of pins (Z)</th> <th>Model</th> <th>Number of pins (Z)</th> </tr> </thead> <tbody> <tr> <td>RV-6E</td> <td rowspan="8">40</td> <td>RV-10C</td> <td rowspan="4">52</td> <td>RV-15</td> <td rowspan="8">40</td> </tr> <tr> <td>RV-20E</td> <td>RV-27C</td> <td>RV-30</td> </tr> <tr> <td>RV-40E</td> <td>RV-50C</td> <td>RV-60</td> </tr> <tr> <td>RV-110E</td> <td>RV-100C</td> <td>RV-160</td> </tr> <tr> <td>RV-160E</td> <td>RV-200C</td> <td>RV-320</td> </tr> <tr> <td>RV-320E</td> <td>RV-320C</td> <td>RV-450</td> </tr> <tr> <td>RV-450E</td> <td>RV-500C</td> <td>RV-550</td> </tr> </tbody> </table>	Model	Number of pins (Z)	Model	Number of pins (Z)	Model	Number of pins (Z)	RV-6E	40	RV-10C	52	RV-15	40	RV-20E	RV-27C	RV-30	RV-40E	RV-50C	RV-60	RV-110E	RV-100C	RV-160	RV-160E	RV-200C	RV-320	RV-320E	RV-320C	RV-450	RV-450E	RV-500C	RV-550
Model	Number of pins (Z)	Model	Number of pins (Z)	Model	Number of pins (Z)																											
RV-6E	40	RV-10C	52	RV-15	40																											
RV-20E		RV-27C		RV-30																												
RV-40E		RV-50C		RV-60																												
RV-110E		RV-100C		RV-160																												
RV-160E		RV-200C	RV-320																													
RV-320E		RV-320C	RV-450																													
RV-450E		RV-500C	RV-550																													
C_{em} — Allowable number of shock torque application times		$C_{em} = \frac{775 \times \left(\frac{T_{S2}}{T_{em}}\right)^{\frac{10}{3}}}{Z_4 \times \frac{N_{em} \times t_{em}}{60}}$ <p>Note $[T_{S2}]$: Momentary maximum allowable torque, E series: Page 12 to 13, C series: Page 38 to 39, Original series: Page 58 to 59 Refer to the individual rating tables.</p>	$C_{em} = \frac{775 \times \left(\frac{833}{500}\right)^{\frac{10}{3}}}{40 \times \frac{15}{60} \times 0.05} = 8,497 \text{ (times)}$																													
Verification of shock torque due to an emergency stop	<p>Check the following condition: The allowable shock torque application count $[C_{em}]$ is equal to or greater than the expected emergency stop count $[P_{em}]$</p> <p>If the tentatively selected reduction gear is outside of the specifications, change the reduction gear model.</p>	<p>$[C_{em}]$ 8,497 $\geq [P_{em}]$ 60</p> <p>According to the above condition, the tentatively selected model should be no problem.</p>																														

Reduction gear selection method (2): Tentatively select a reduction gear model and evaluate the service life.

Setting/verification item	Calculation formula	Selection examples (With horizontal rotational transfer)
(5) Verify the thrust load and moment load. (It is not necessary to determine these for the Original series.)		
W_1 ——— Radial load (N) ℓ ——— Distance to the point of radial load application (mm) W_2 ——— Thrust load (N) ℓ_2 ——— Distance to the point of thrust load application (mm) M ——— Moment load (Nm)	$M = \frac{W_1 \times (\ell + b - a) + W_2 \times \ell_2}{1,000}$ <p>a, b: Refer to the calculation of the tilt angle on page 99.</p>	0 (N) 0 (mm) In this selection example, $W_2 = (180 + 20 \times 4) \times 9.8$ $= 2,548 \text{ (N)}$ Note 1. W_a, W_b : Refer to page 83. 0 (mm) (As the workpiece center is located on the rotation axis) RV-20E As dimension $a = 20.1 \text{ (mm)}$ and dimension $b = 113.3 \text{ (mm)}$: $M = \frac{0 \times (0 + 113.3 - 20.1) + 2,548 \times 0}{1,000}$ $= 0 \text{ (Nm)}$
Verify the thrust load and moment load	Check that the thrust load and moment load are within the range in the allowable moment diagram on page 91. Wr: Allowable radial load: E series: Page 12 to 13, C series: Page 38 to 39, Original series: Page 58 to 59 Refer to the individual rating tables. If the tentatively selected reduction gear is outside of the specifications, change the reduction gear model.	For this example, Thrust load $[W_2] = 2,548 \text{ (N)}$ Moment load $[M] = 0 \text{ (N)}$ As the above values are within the range in the allowable moment diagram, the tentatively selected model should be no problem.
(6) Verify the reduction gear service life.		
L_h ——— Life (h)	$L_h = 6,000 \times \frac{N_0}{N_m} \times \left(\frac{T_0}{T_m}\right)^{\frac{10}{3}}$	$L_h = 6,000 \times \frac{15}{12} \times \left(\frac{167}{110.2}\right)^{\frac{10}{3}}$ $= 29,981 \text{ (h)}$
Q_{1cy} ——— Number of cycles per day (times)	$Q_{1cy} = \frac{Q_1 \times 60 \times 60}{t_4}$	$Q_{1cy} = \frac{12 \times 60 \times 60}{20} = 2,160 \text{ (times)}$
Q_3 ——— Operating hours per day (h)	$Q_3 = \frac{Q_{1cy} \times (t_1 + t_2 + t_3)}{60 \times 60}$	$Q_3 = \frac{2,160 \times (0.5 + 1.5 + 0.5)}{60 \times 60} = 1.5 \text{ (h)}$
Q_4 ——— Operating hours per year (h)	$Q_4 = Q_3 \times Q_2$	$Q_4 = 1.5 \times 365 = 548 \text{ (h)}$
L_{year} ——— Reduction gear service life (year)	$L_{year} = \frac{L_h}{Q_4}$	$L_{year} = \frac{29,981}{548} = 54.7 \text{ (year)}$
L_{ex} ——— Required life (year)	Based on the operation conditions	5 years
Verification of the service life	Check the following condition: $[L_{ex}]$ is equal to or less than $[L_{year}]$ If the tentatively selected reduction gear is outside of the specifications, change the reduction gear model.	$[L_{ex}] 5 \text{ (year)} \leq [L_{year}] 54.7 \text{ (year)}$ According to the above condition, the tentatively selected model should be no problem.
Select the reduction gear model that satisfies all the conditions of the above verification items. The actual reduction ratio is determined based on the motor speed, input torque, and inertia moment. Check with the motor manufacturer.		Based on the above verification result, RV-20E is selected.

Limitation on the motor torque

A limitation is imposed on the motor torque value so that the shock torque applied to the reduction gear does not exceed the momentary maximum allowable torque.

Setting/verification item	Calculation formula	Selection examples (With horizontal rotational transfer)
T_{M1} Motor momentary maximum torque (Nm)	Determine based on the motor specifications.	For example, $T_{M1} = 10$ (Nm)
T_{M1OUT} Maximum torque generated at the output shaft for the reduction gear (Nm) (When an external shock is applied at the time of an emergency stop or motor stop)	$T_{M1out} = T_{M1} \times R \times \frac{100}{\eta}$ R: Speed ratio η : Startup efficiency (%) ,E series: Page 12 to 13, C series: Page 38 to 39, Original series: Page 58 to 59 Refer to the individual rating tables.	For example, calculate the maximum torque generated at the output shaft for the reduction gear based on the specifications when RV-20E-161 was selected. $T_{M1out} = 10 \times 161 \times \frac{100}{75}$ $= 2,147(\text{Nm})$
T_{M2OUT} Maximum torque generated at the output shaft for the reduction gear (Nm) (When a shock is applied to the output shaft due to hitting by an obstacle)	$T_{M2out} = T_{M1} \times R \times \frac{\eta}{100}$	$T_{M2out} = 10 \times 161 \times \frac{75}{100}$ $= 1,208(\text{Nm})$
Limitation on motor torque value	Check the following condition: The momentary maximum allowable torque $[T_{S2}]^1$ is equal to or greater than the maximum torque generated at the output shaft for the reduction gear $[T_{M1OUT}]$ and $[T_{M2OUT}]$ If the above condition is not satisfied, a limitation is imposed on the maximum torque value of the motor. ^{*1} $[T_{S2}]$: E series: Page 12 to 13, C series: Page 38 to 39, Original series: Page 58 to 59 Refer to the individual rating tables.	$[T_{S2}] 833 (\text{Nm}) \leq [T_{M1OUT}] 2,147 (\text{Nm})$ and $[T_{S2}] 833 (\text{Nm}) \leq [T_{M2OUT}] 1,208 (\text{Nm})$ According to the above condition, the torque limit is set for the motor.

Allowable Moment Diagram

E series

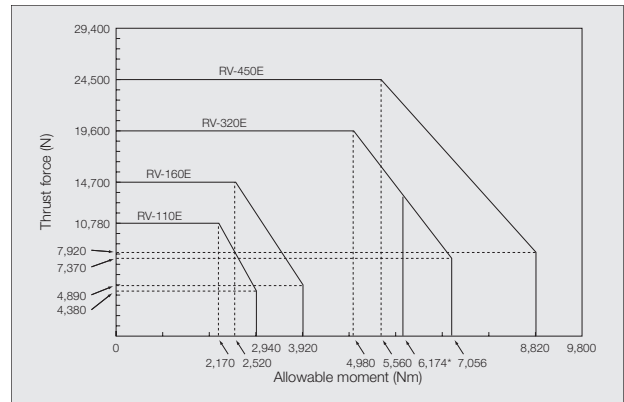
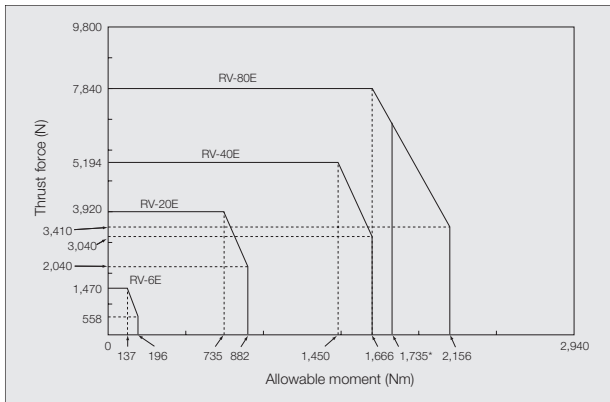

* Value is for the pin/bolt-clamping output-shaft type.

C series

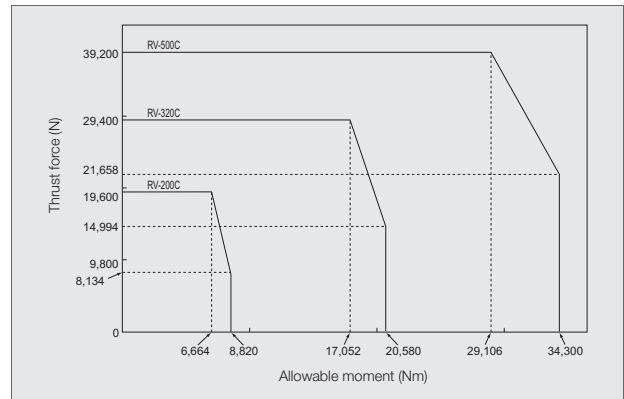
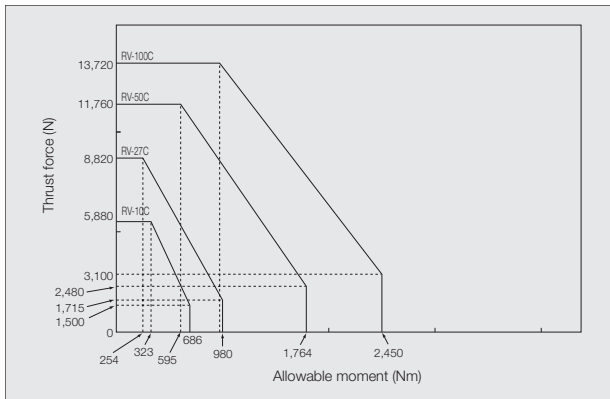

Backdriving torque

The backdriving torque refers to a torque required for starting the output shaft. If the input shaft (input gear) is released while a torque equal to or more than the backdriving torque is kept applied to the output shaft, the input shaft (input gear) starts running at an augmented speed. Special care should be given to the backdriving torque required to start the reduction gear.

E series

Model	Backdriving torque Nm
RV-6E	10
RV-20E	42
RV-40E	47
RV-80E	70
RV-110E	80
RV-160E	110
RV-320E	220
RV-450E	270

C series

Model	Backdriving torque Nm
RV-10C	10
RV-27C	52
RV-50C	95
RV-100C	120
RV-200C	150
RV-320C	220
RV-500C	300

Test conditions
Lubricant: grease (Molywhite RE00)

Original series

Model	Backdriving torque Nm
RV-15	21
RV-30	38
RV-60	69
RV-160	110
RV-320	210
RV-450	260
RV-550	330

Technical Data

No-load Running Torque

Use the following formula to calculate the no-load running torque converted to the motor shaft.

$$\text{No-load running torque converted to the motor shaft (Nm)} = \frac{\text{Torque converted into the output shaft (Nm)}}{R} \quad (R: \text{speed ratio value})$$

[Measurement conditions]
Case temperature: 30 (°C)
Lubricant: Grease
(Molywhite RE00)

Note: The values in the following graphs are for the reduction gear alone, and indicate the average values after the break-in period.

E series

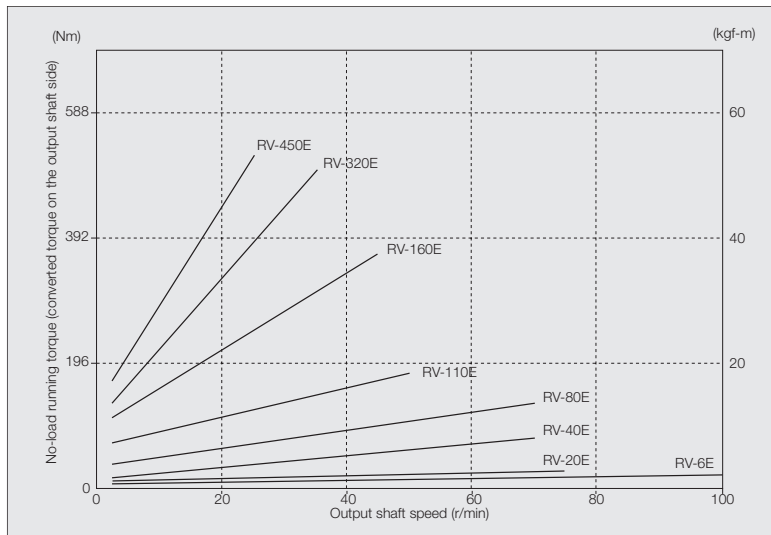

C series

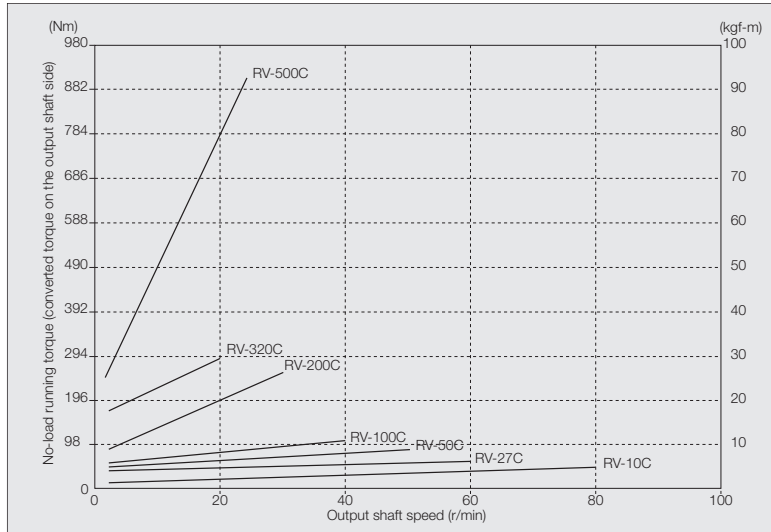

Original series

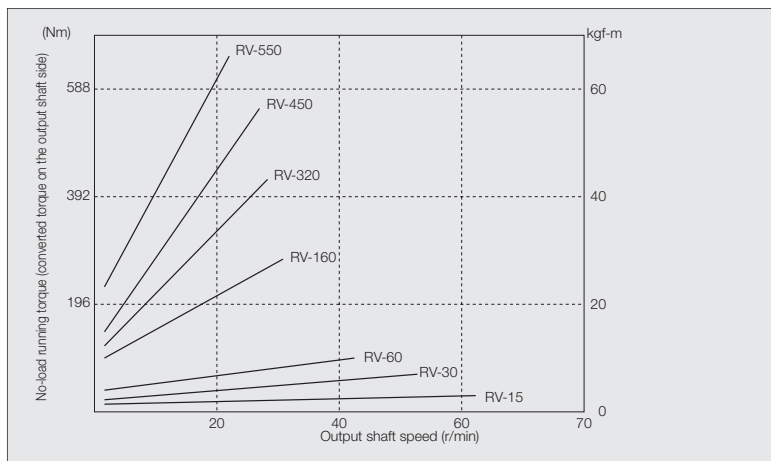

Low Temperature Characteristic

When the reduction gear is used at a low temperature, viscosity of lubricant increases and causes a larger no-load running torque. The no-load running torque at low temperature is shown below.

Use the following formula to calculate the no-load running torque converted to the motor shaft.

$$\text{No-load running torque converted to the motor shaft (Nm)} = \frac{\text{Torque converted into the output shaft (Nm)}}{R} \quad (R: \text{speed ratio value})$$

[Measurement conditions]
 Input speed: 2,000 rpm
 (E series, Original series)
 Output speed: 15 rpm (C series)
 Lubricant: Grease
 (Molywhite RE00)

E series

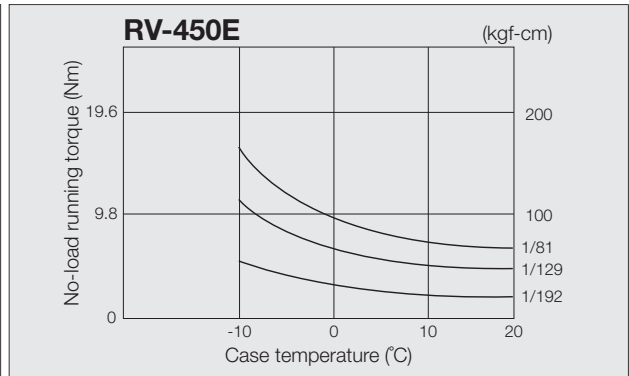
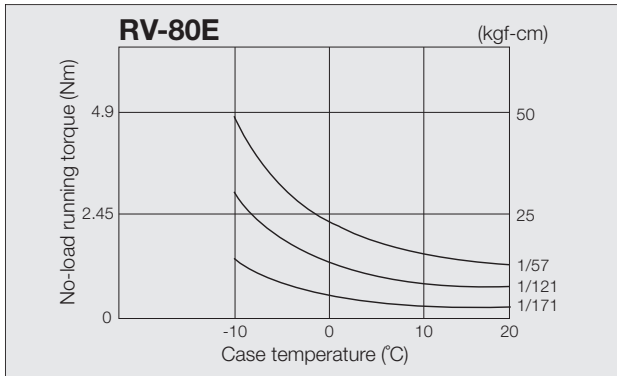
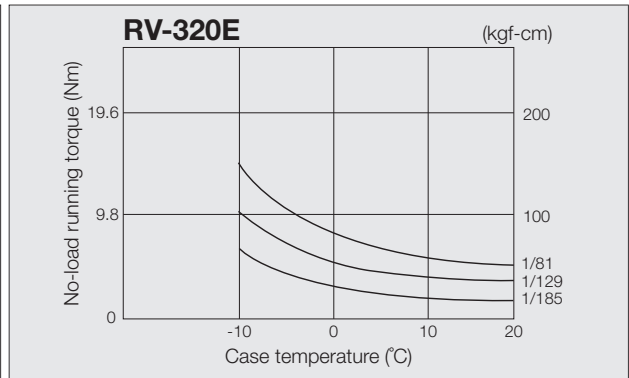
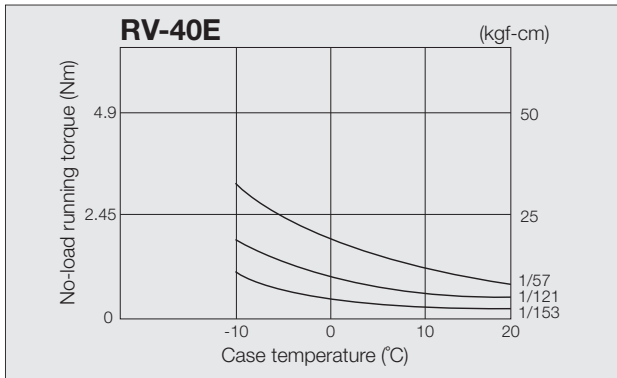
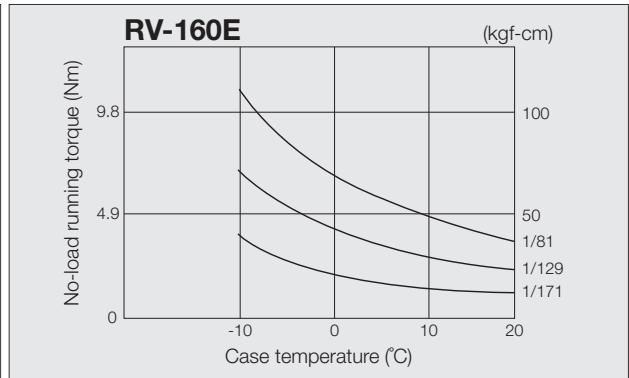
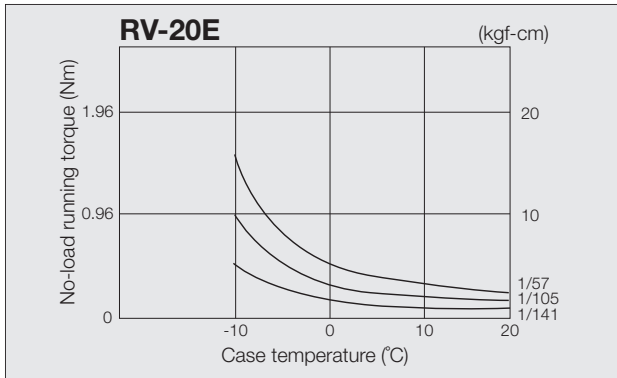
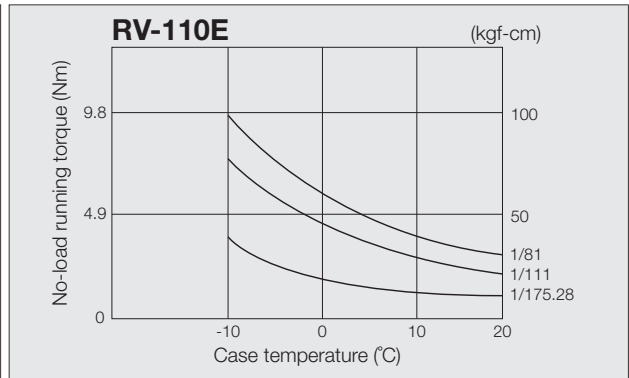
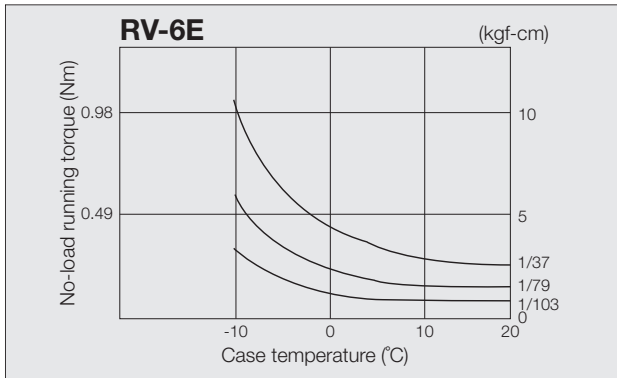

Technical Data

Low Temperature Characteristic

C series*

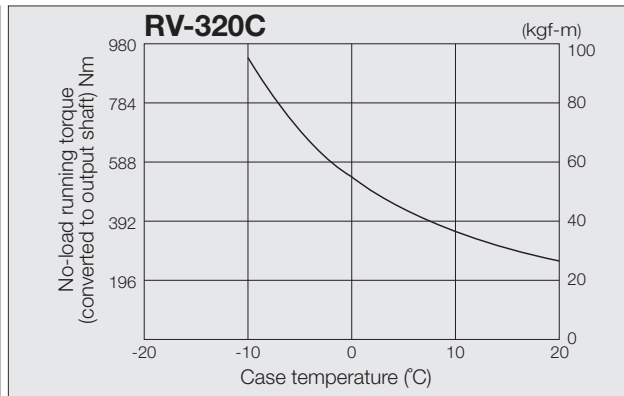
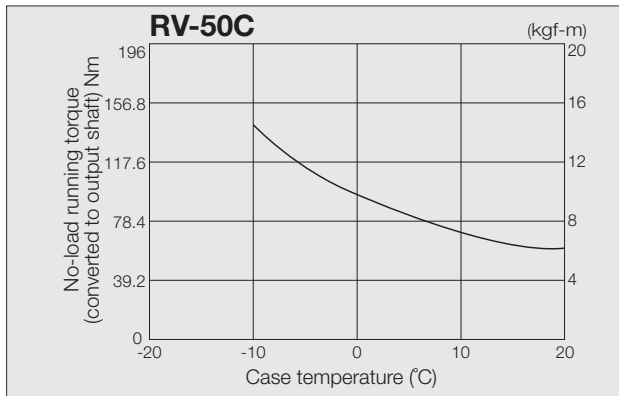
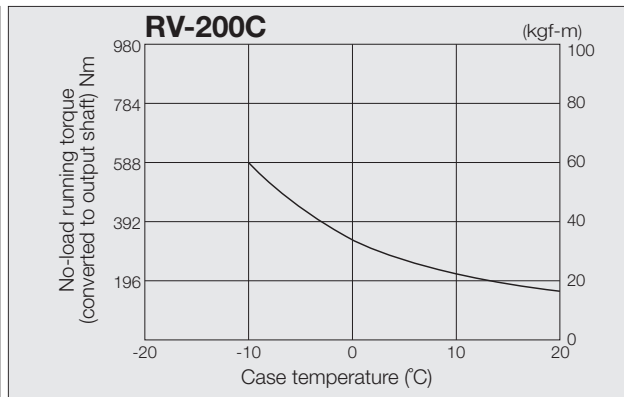
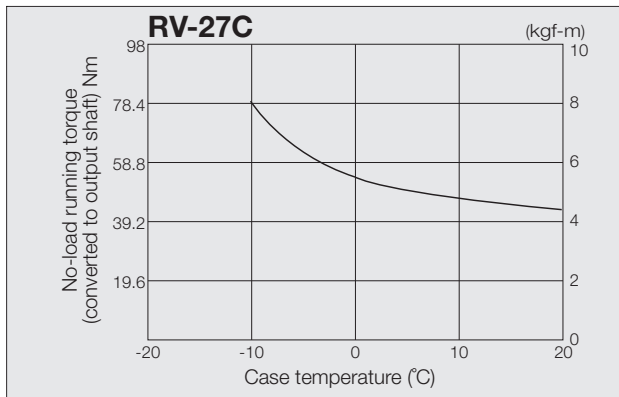
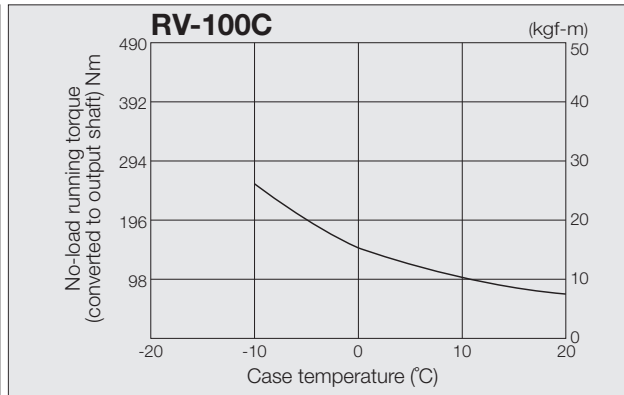
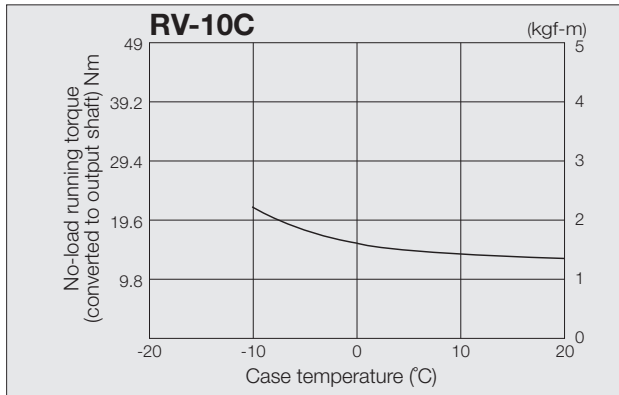

* Values do not include losses for the center gear.

Original series

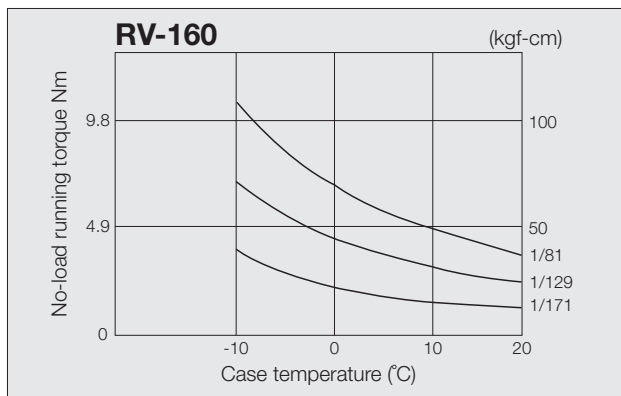
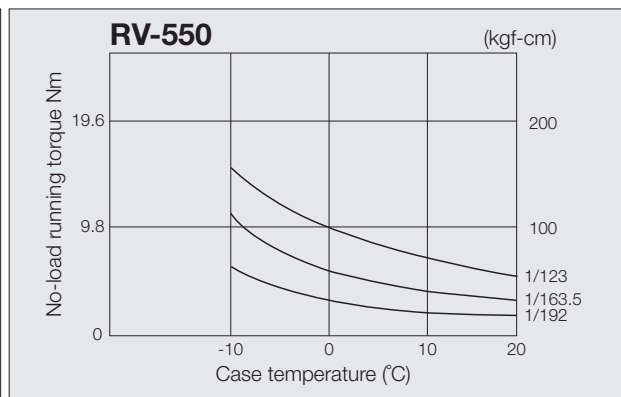
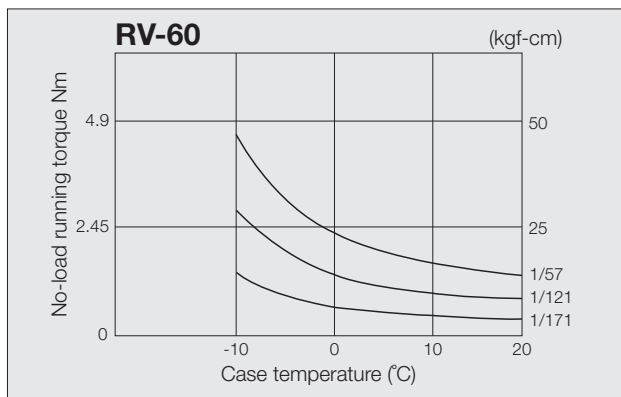
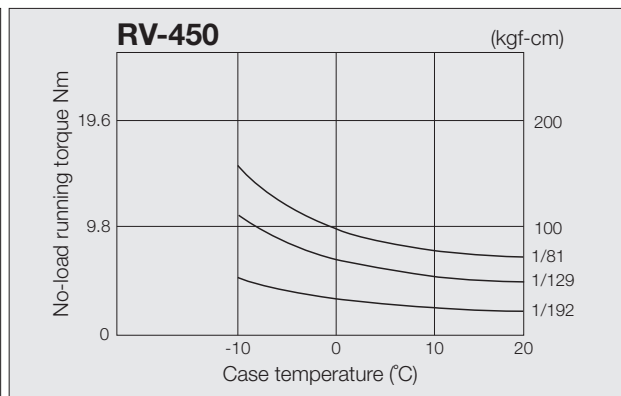
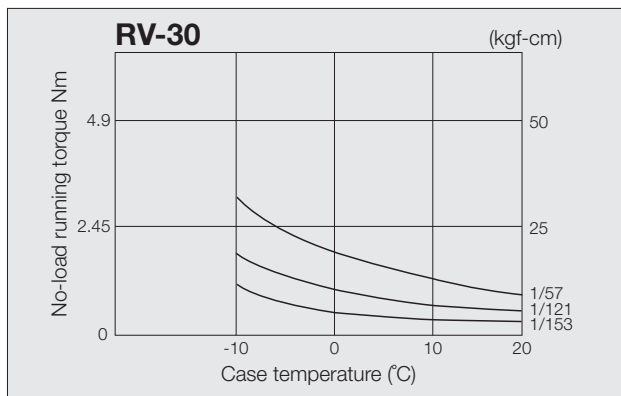
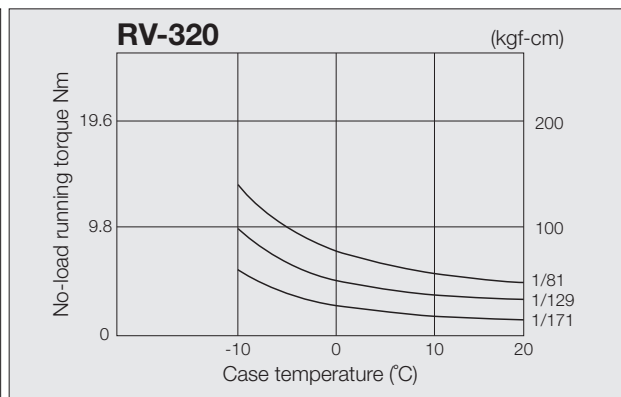
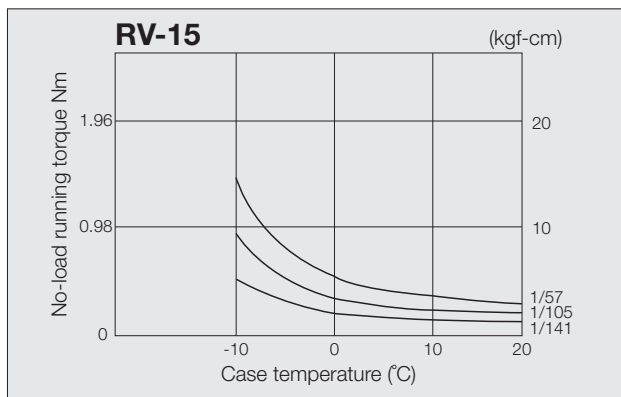

Technical Data

Efficiency Table

[Measurement conditions]
 Case temperature: 30 (°C)
 Lubricant: Grease (Molywhite RE00)

E series

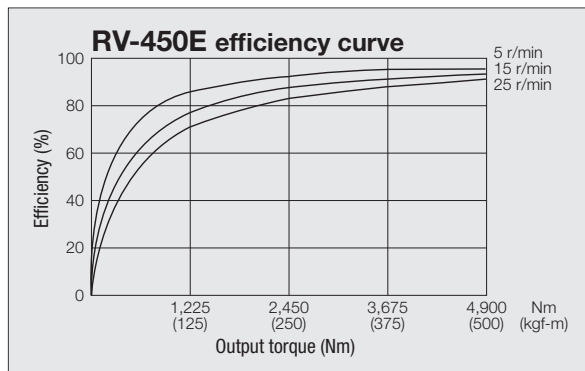
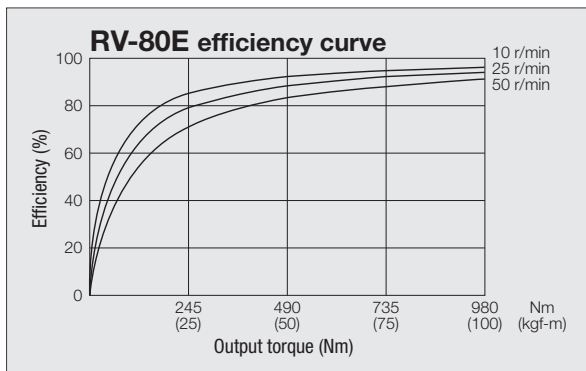
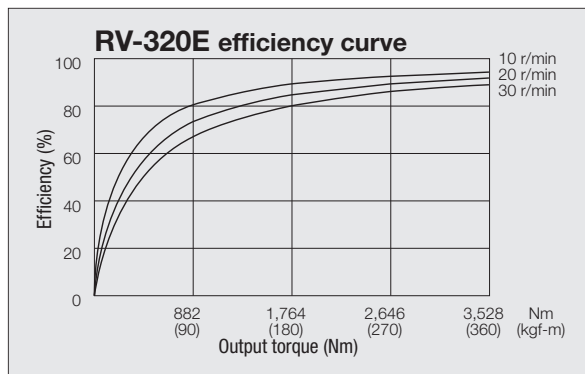
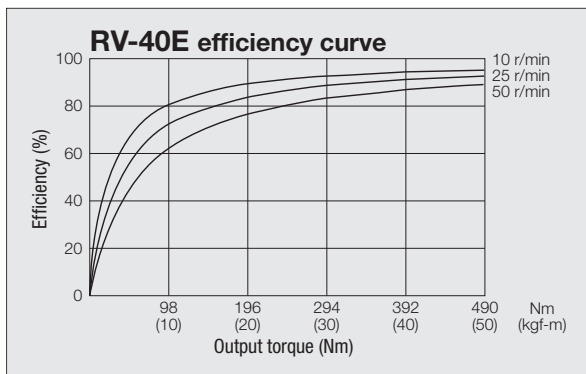
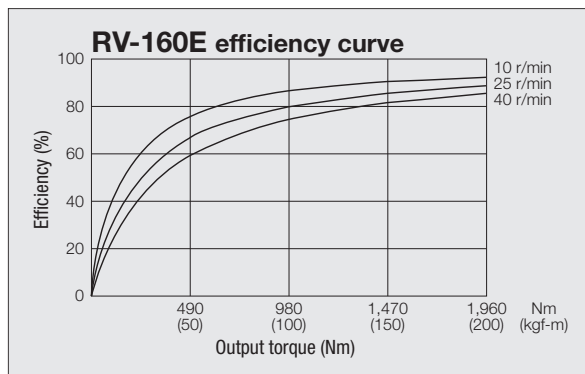
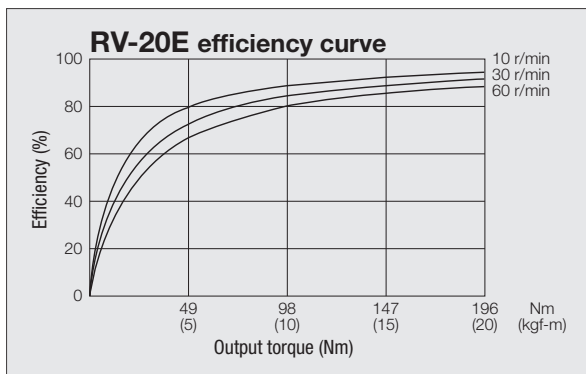
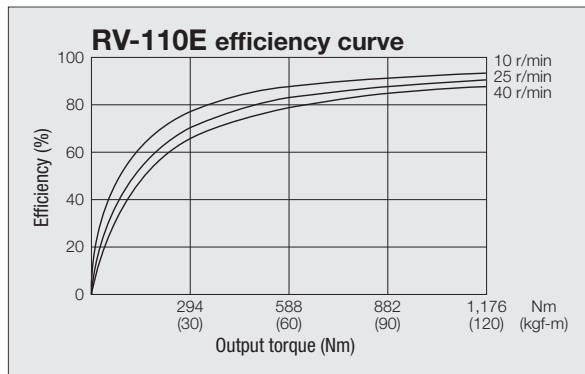
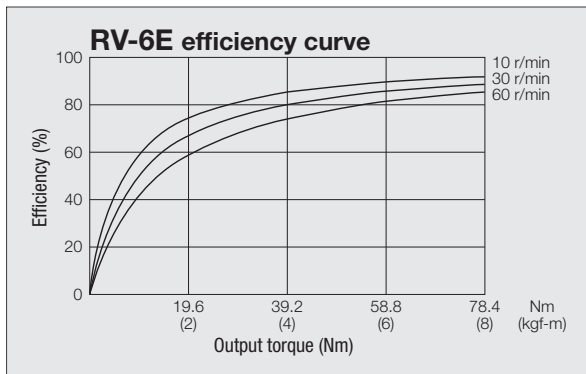

C series*

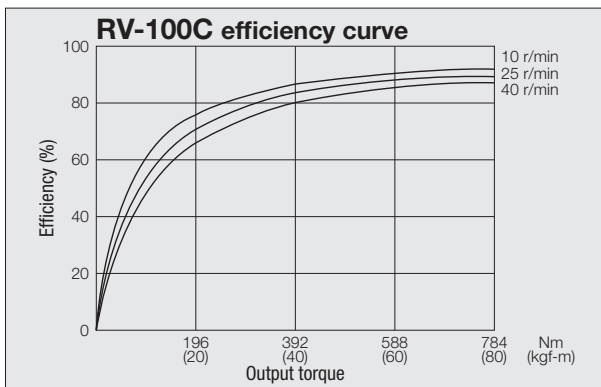
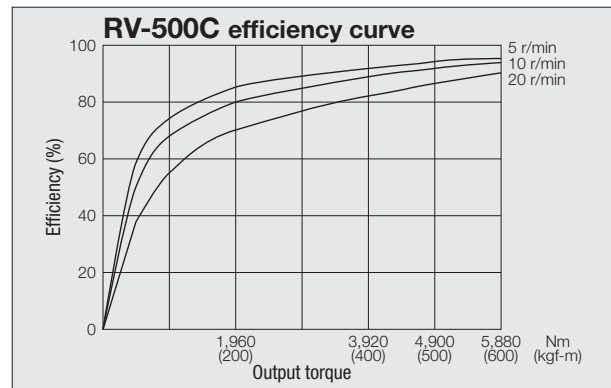
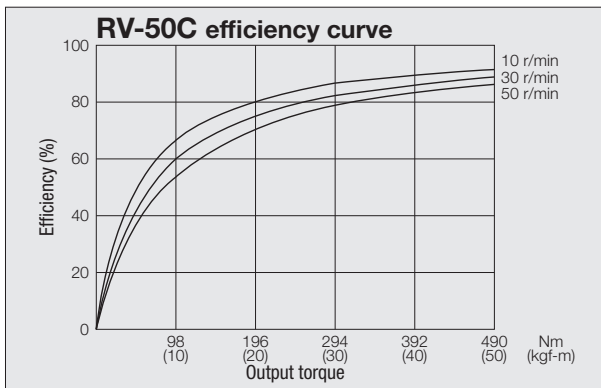
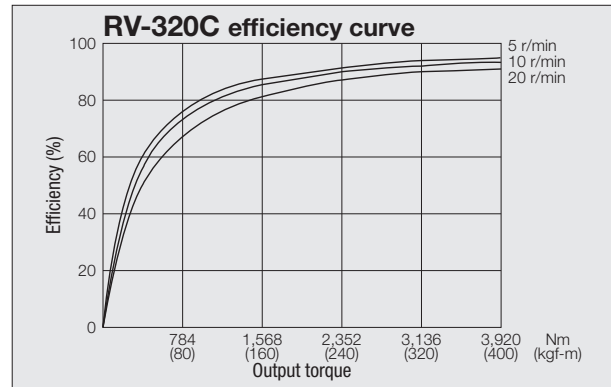
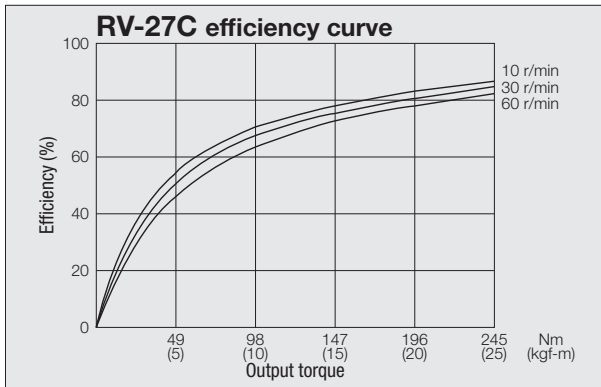
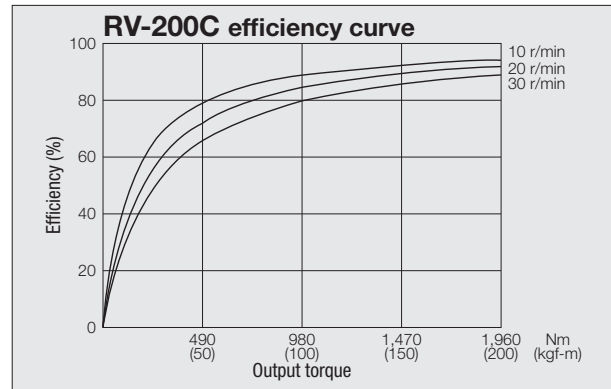
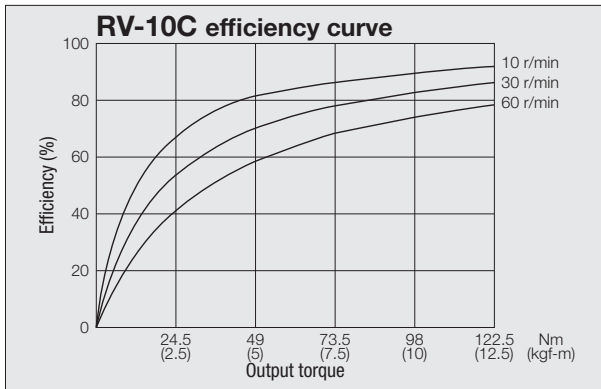

* Values do not include losses for the center gear.

Technical Data

Efficiency Table

Original series

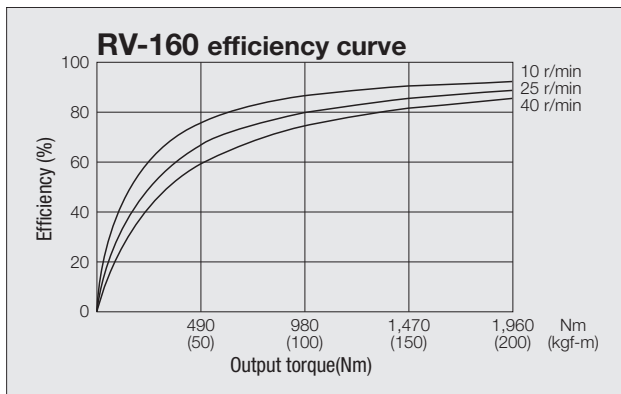
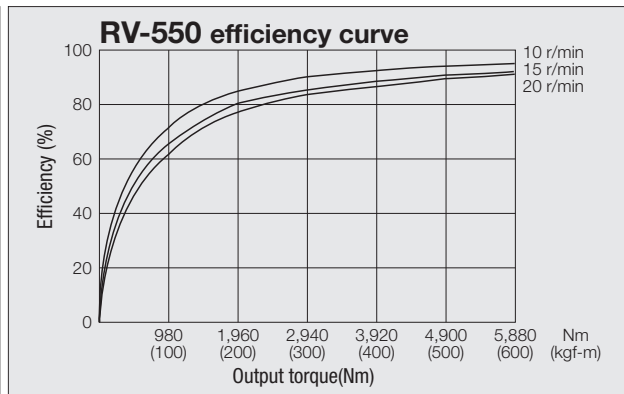
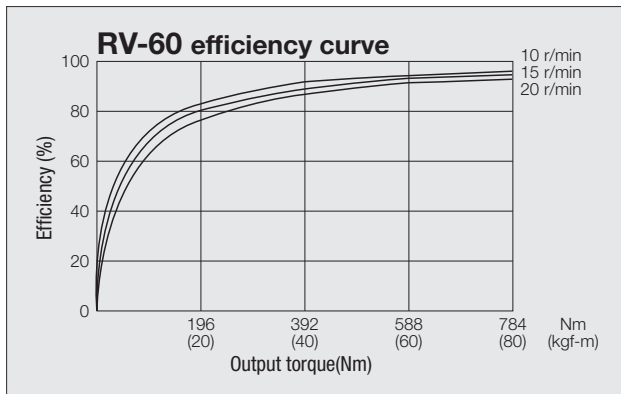
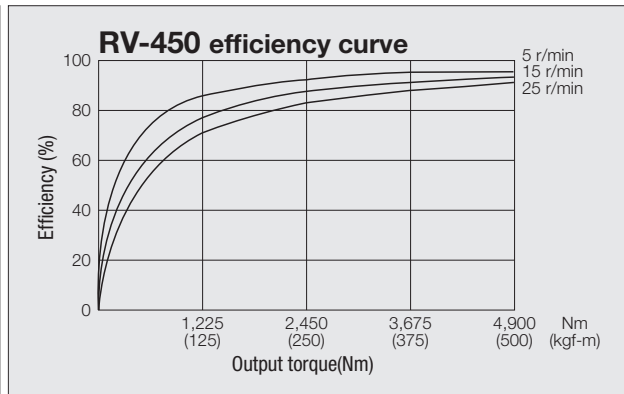
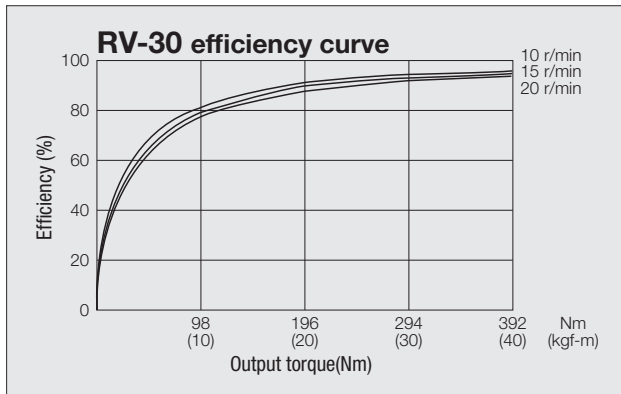
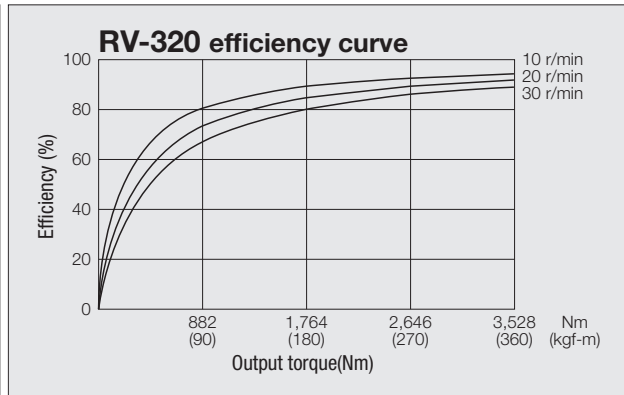
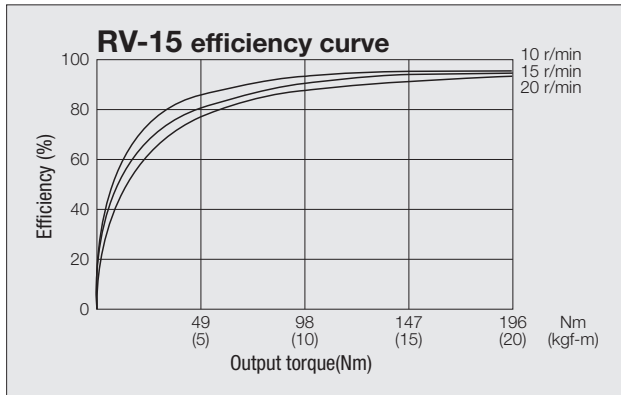

Design Points

Mounting Bolts

Installation of the reduction gear and mounting it to the output shaft

When installing the reduction gear and mounting it to the output shaft, use hexagon socket head cap screws and tighten to the torque, as specified below, in order to satisfy the momentary maximum allowable torque, which is noted in the rating table.

The use of the Belleville spring washers are recommended to prevent the bolt from loosening and protect the bolt seat surface from flaws.

• Hexagon socket head cap screw

<Bolt tightening torque and tightening force>

Hexagon socket head cap screw nominal size x pitch (mm)	Tightening torque (Nm)	Tightening force F (N)	Bolt specification
M5 × 0.8	9.01 ± 0.49	9,310	Hexagon socket head cap screw JIS B 1176: 2006 Strength class JIS B 1051: 2000 12.9 Thread JIS B 0209: 2001 6g
M6 × 1.0	15.6 ± 0.78	13,180	
M8 × 1.25	37.2 ± 1.86	23,960	
M10 × 1.5	73.5 ± 3.43	38,080	
M12 × 1.75	129 ± 6.37	55,100	
M16 × 2.0	319 ± 15.9	103,410	
M18 × 2.5	441 ± 22.0	126,720	

Note: 1. The tightening torque values listed are for steel or cast iron material.

2. If softer material, such as aluminum or stainless, is used, limit the tightening torque. Also take the transmission torque and load moment into due consideration.

<Calculation of allowable transmission torque of bolts>

$T = F \times \mu \times \frac{D}{2 \times 1,000} \times n$	T	Allowable transmission torque by tightening bolt (Nm)
	F	Bolt tightening force (N)
	D	Bolt mounting P.C.D. (mm)
	μ	Friction factor μ=0.15: When lubricant remains on the mating face. μ=0.20: When lubricant is removed from the mating face.
	n	Number of bolts (pcs.)

• Serrated lock washer for hexagon socket head cap screw

Name: Belleville spring washer (made by Heiwa Hatsujo Industry Co., Ltd.)

Corporation symbol: CDW-H

CDW-L (Only for M5)

Material: S50C to S70C

Hardness: HRC40 to 48

(Unit: mm)

Nominal size	ID and OD of Belleville spring washer		t	H
	Ød	ØD		
5	5.25	8.5	0.6	0.85
6	6.4	10	1.0	1.25
8	8.4	13	1.2	1.55
10	10.6	16	1.5	1.9
12	12.6	18	1.8	2.2
16	16.9	24	2.3	2.8
18	18.9	27	2.6	3.15

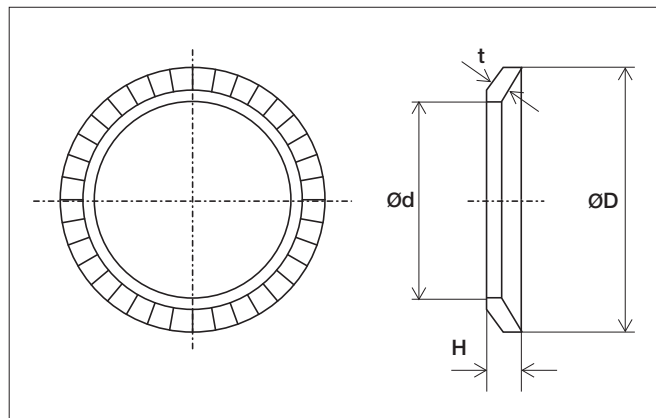

Note: When using any equivalent washer, select it with special care given to its outside diameter.

Design Points

Input Gears

Pass-through capacity of input gear

Lower ratio input gears may have diameters too large to pass through the RV gear center. The following table shows which ratios can and can not allow the input gear to pass through.

E series

(Unit: mm)

Model	Hole dia.		Depth ℓ	Speed ratio adequate for shaft passage (1-piece input gear)		Speed ratio inadequate for shaft passage (2-piece input gear)	
	d1	d2		Shaft revolution	Case revolution	Shaft revolution	Case revolution
	RV-6E	19	21	18	53.5, 59, 79, 103	52.5, 58, 78, 102	31, 43
RV-20E	22	24	18.5	81, 105, 121, 141	80, 104, 120, 140	57	56
RV-40E	27	30	23.5	81, 105, 121, 153	80, 104, 120, 152	57	56
RV-80E	37	40	23	81, 101, 121, 153	80, 100, 120, 152	57	56
RV-110E	39	42	20	81, 111, 127.7 161, 175.2	80, 110, 126.7 160, 174.2	—	—
RV-160E	43	47	30	81, 101, 129, 145, 171	80, 100, 128, 144, 170	66*	65*
RV-320E	47	52	34	81, 101, 118.5 129, 141, 171, 185	80, 100, 117.5 128, 140, 170, 184	66*	65*
RV-450E	57	62	40	81, 101, 118.5 129, 155, 171, 192	80, 100, 117.5 128, 154, 170, 191	66*	65*

*Not described on the rating table. Please consult Nabtesco if needed.

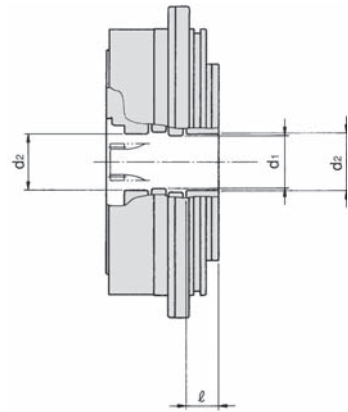

Original series

(Unit: mm)

Model	Hole dia.		Depth ℓ	Speed ratio adequate for shaft passage (1-piece input gear)		Speed ratio inadequate for shaft passage (2-piece input gear)	
	d1	d2		Shaft revolution	Case revolution	Shaft revolution	Case revolution
	RV-15	22	24	21	81, 105, 121, 141	80, 104, 120, 140	57
RV-30	27	30	19.5	81, 105, 121, 153	80, 104, 120, 152	57	56
RV-60	37	40	17.5	81, 101, 121, 153	80, 100, 120, 152	57	56
RV-160	43	47	22	81, 101, 129, 145, 171	80, 100, 128, 144, 170	66*	65*
RV-320	47	52	28.3	81, 101, 118.5 129, 141, 171, 185	80, 100, 117.5 128, 140, 170, 184	66*	65*
RV-450	57	62	28.5	81, 101, 118.5, 129 154.84, 171, 192.42	80, 100, 117.5, 128 153.84, 170, 191.42	66*	65*
RV-550	66	72	33	123, 141, 163.5, 192.4	122, 140, 162.5, 191.4	—	—

*Not described on the rating table. Please consult Nabtesco if needed.

An example of installation for the reduction gear with lower speed ratio

The lower the speed ratio, the larger the outside diameter of the input gear. Therefore, the installation of the input gear through the reduction gear is not possible with all ratios. In such cases a two-piece input gear is required. Refer to "External Dimensions".

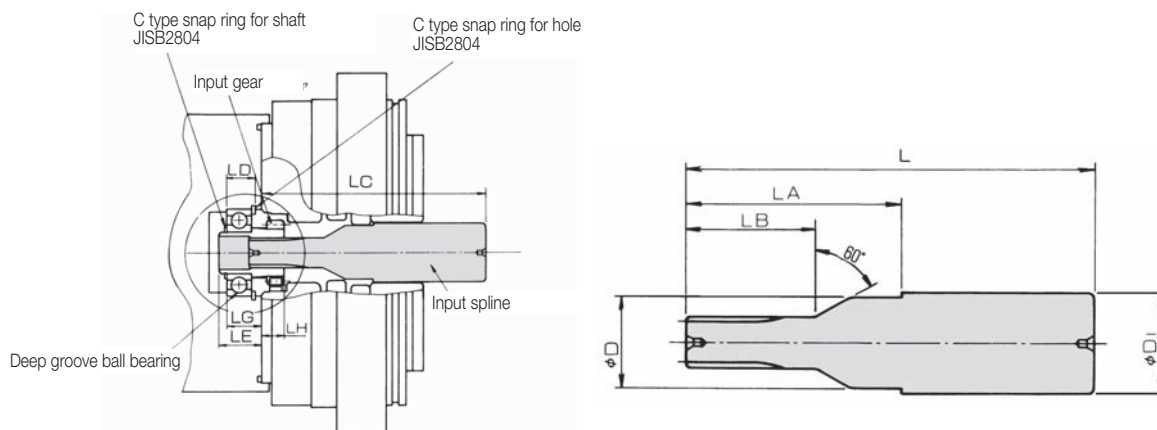

E series, Original series

(Unit: mm)

Model	L	LA	LB	D	D1	LC	LD ^{+0.1}	LE	LG ^{+0.1}	LH	Deep groove ball bearing
RV-6E	96	60	23	18	28	92	10.3	16	13	7.5	6002
RV-20E, RV-15	95	53	30	21.5	23.5	90	11.7	17	14	9	6003
RV-40E, RV-30	105	58	30	26.5	29.5	103	13.9	19	16	11.5	6004
RV-80E*1, RV-60	110	—	35	36	←	109	13.9	15.5	12	16	6005
RV-80E*2, RV-60	110	—	35	36	←	105	13.9	19.5	16	12	6005
RV-160E, RV-160	130	—	38	42	←	128	15.1	21	17	16	6006
RV-320E, RV-320	155	—	48	46	←	148	16.1	22	18	20	6007
RV-450E, RV-450	200	—	48	56	←	195	17.6	26	22.5	21	6008

Note: Deep groove ball bearing and C-shaped snap rings are to be provided by the customer. *1: Bolt clamping output shaft type *2: Pin/bolt clamping output shaft type

Design Points

Input Gears

Accuracy of center gear and input gear for C series

Poor installation accuracy of center gear and input gear may cause noise and backlash, so design center gear and input gear to the following accuracy.

Note: Attach a bearing to the input gear to accommodate the reaction torque from the center gear.

Accuracy of center gear and input gear

(Unit: mm)

Tolerance of fitting X	Tolerance of concentricity a	Tooth grade of small center gear	Tooth grade of large center gear	Tooth grade of input gear
h6	MAX0.03	JIS 5 class or lower	JIS 4 class or lower	JIS 5 class or lower

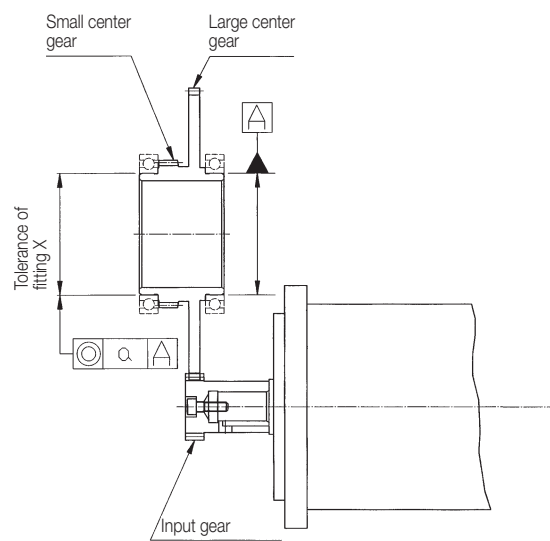

(Unit: mm)

	Backlash between input gear and large center gear
RV-10C	0.035 to 0.090
RV-27C	0.040 to 0.110
RV-50C	0.050 to 0.130
RV-100C	0.060 to 0.140
RV-200C	0.075 to 0.180
RV-320C	
RV-500C	

Specifications of small center gear tooth

	Module	Number of teeth	Addendum modification coefficient
RV-10C	1.0	48	-0.04
RV-27C	1.0	57	+0.2
RV-50C	1.25	61	0
RV-100C	1.75	48	+0.3
RV-200C	2.5	43	0
RV-320C	2	78	0
RV-500C	2	83	0

Standard center gear

The standard center gears for C series are available from Nabtesco.

If the standard center gear is needed, please specify when ordering. Specifications of standard large center gears are shown below. Refer to the external dimension for installation.

Specifications of standard large center gear

	Module	Number of teeth	Addendum modification coefficient	Base tangent length (mm)	Number of teeth for measuring base tangent length
RV-10C	2	57	0	39.974 ^{-0.017} _{-0.042}	7
RV-27C	1.25	78	0	32.732 ^{-0.023} _{-0.061}	9
RV-50C	2	78	0	52.371 ^{-0.023} _{-0.061}	9
RV-100C	1.75	112	0	67.323 ^{-0.028} _{-0.066}	13
RV-200C	2	110	0	76.885 ^{-0.035} _{-0.085}	13
RV-320C	2	125	0	89.113 ^{-0.035} _{-0.085}	15
RV-500C	2	150	0	101.622 ^{-0.035} _{-0.085}	17

We provide a variety of standard input gears for each speed ratio that can be additionally machined by customers for the E series and Original series. Please machine and install the standard input gear based on the customer's intended use, by referring to the following examples. Note: For the model and reduction speed ratio provided with the standard input gears, refer to "Dimensions of standard input gear" on page 107 and 108.

Standard input gear specifications

Material	
Heat treatment	Carburizing, quenching and tempering
Surface hardness	HRC58 to 62 (excluding the carburizing prevention range)
Material	SCM415 Normalizing or equivalent material

<Standard input gear A: For small motors>

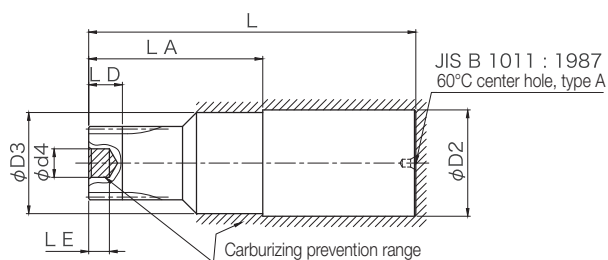

<Standard input gear B: For large motors>

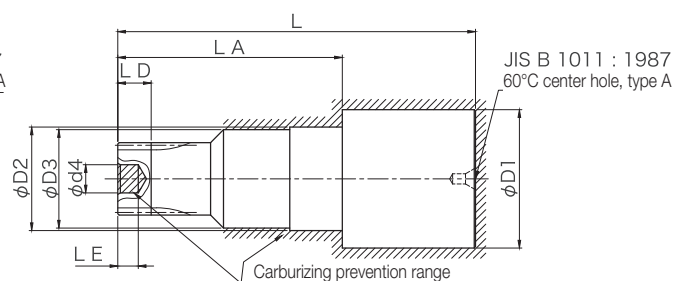

Note: The above drawing shows the shape before the additional machining is performed. Check the dimensions of each section in the "Dimensions" table on pages 107 and 108.

Reference for additional machining

Standard input gears come equipped with center holes and ground boss outer diameter (D1).

When modifying them, use the center hole or boss outer diameter (D1) as the reference surface.

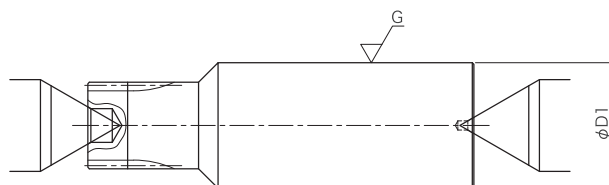

Design of the input gear

Please refer to the chart below. Use it as a reference when the customer designs an input gear on their own.

•Design flow

When modifying the standard input gear

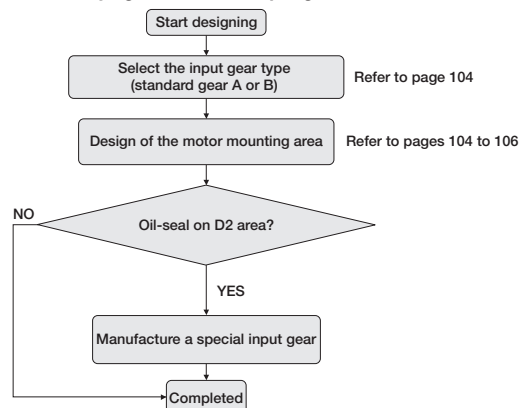

When manufacturing a special input gear

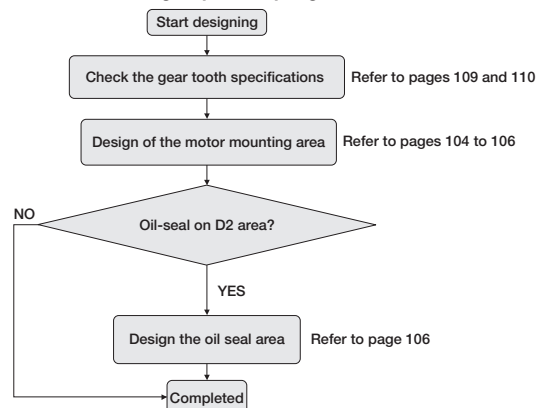

Design Points

Input Gears

•Selection of the input gear type

There are the following two types of standard input gear:

Standard input gear A: For small motors

Standard input gear B: For large motors

Select the type of input gear to be used by referring to the tables below.

Applicable motor shaft diameters for standard input gear

(Unit: mm)

Model	Standard input gear A	Standard input gear B
RV-6E	ø16 or less	
RV-20E, RV-15	Less than ø14	ø14 or more
RV-40E, RV-30	Less than ø19	ø19 or more
RV-80E, RV-60	Less than ø24	ø24 or more
RV-110E	ø24 or less	

(Unit: mm)

Model	Standard input gear A	Standard input gear B
RV-160E, RV-160	Less than ø28	ø28 or more
RV-320E, RV-320	Less than ø32	ø32 or more
RV-450E, RV-450	Less than ø42	ø42 or more
RV-550	ø40 or less	

Note: Some models have only standard input gear A.

•Design of the motor mounting area

<(Design example 1: For straight shafts (attached to motor shaft tip))>

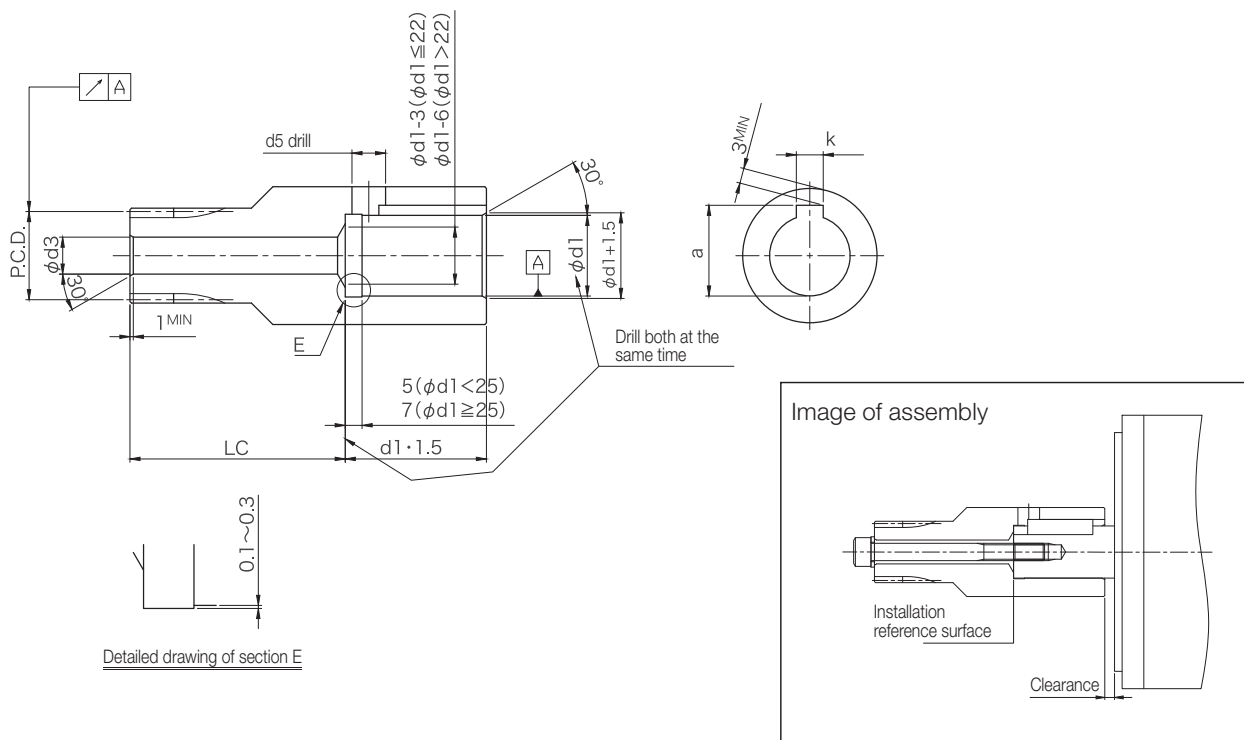

- Note 1. When a tapped hole is used for the motor shaft, fix the input gear to the motor shaft with a bolt.
- For the bolt through hole diameter (d_3), radial runout, and the shaft hole position (LC), refer to "Dimensions after modification" in the "Dimensions" table on pages 107 and 108.
 - If the bolt through hole diameter (d_3) is larger than the center hole diameter on the tooth surface side (d_4), it is necessary to process the carburized surface. In such a case, confirm the applicable tools and processing conditions, etc.
 - The clearance hole diameter for the keyway (d_5) is "keyway width (k) + 2 mm", approximately. (The clearance hole diameter must be larger than the keyway width (k).
 - Design the motor shaft hole diameter (d_1) according to the motor shaft diameter to be used.
 - For the keyway width (k) and keyway height (a), refer to the specifications of the key to be used.

<Design example 2: For straight shafts (attached to motor shaft base)>

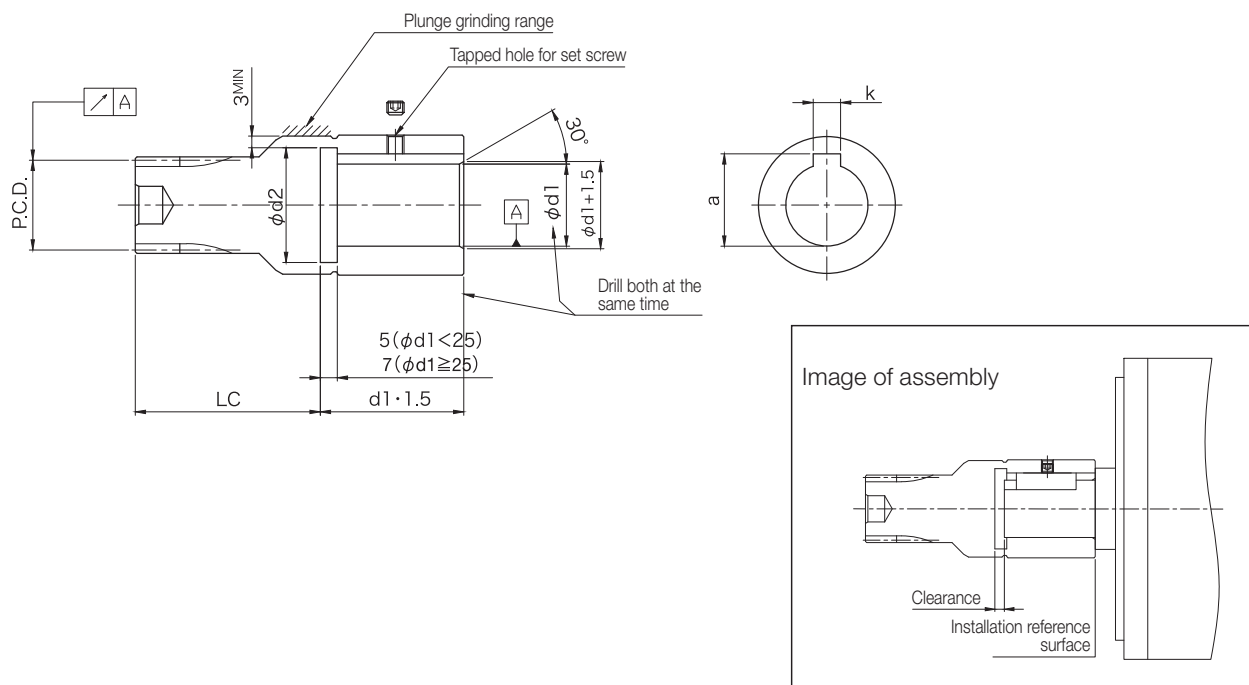

- Note 1.** When a tapped hole is not used for the motor shaft, fix the input gear to the motor shaft with a set screw.
- 2.** If a clearance hole for the keyway cannot be drilled due to some reason, such as the plunge grinding area being located on the outer periphery, create a recessed groove instead.
- 3.** For the radial runout and the shaft hole position (LC), refer to “Dimensions after modification” in the “Dimensions” table on pages 107 and 108.
- 4.** Design the motor shaft diameter (d1) according to the motor shaft diameter to be used.
- 5.** For the keyway width (k) and keyway height (a), refer to the specifications of the key to be used.
- 6.** Design the diameter of the recessed groove for the keyway (d2) according to the following instructions.

- Recessed groove diameter for keyway

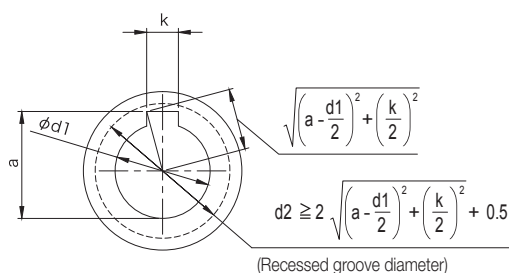

Set the diameter of the recessed groove (d2) so that it is larger than the corner of the keyway.

$$d2 \geq 2 \cdot \sqrt{\left(a - \frac{d1}{2}\right)^2 + \left(\frac{k}{2}\right)^2} + 0.5$$

Although the above calculation formula is used in this example, design the diameter using appropriate values, based on the keyway tolerance, processing tolerance, etc. The following is an example of when the diameter of the recessed groove is selected based on the above calculation formula. Use it as a reference when designing.

Selection examples of recessed groove diameter (d2)

(Unit: mm)

Motor shaft hole diameter $\phi d1$	Keyway width k	Keyway height a	Recessed groove diameter $\phi d2$
8	3	9.4	12
9	3	10.4	13
10	4	11.8	15
11	4	12.8	16
14	5	16.3	20
15	5	17.3	21
16	5	18.3	22
17	6	19.8	24
19	6	21.8	26

(Unit: mm)

Motor shaft hole diameter $\phi d1$	Keyway width k	Keyway height a	Recessed groove diameter $\phi d2$
22	8	25.3	31
24	8	27.3	33
25	8	28.3	34
28	8	31.3	37
32	10	35.3	41
35	10	38.3	44
38	10	41.3	47
38	12	41.3	47
42	12	45.3	51

Design Points

Input Gears

<Design example 3: For tapered shafts>

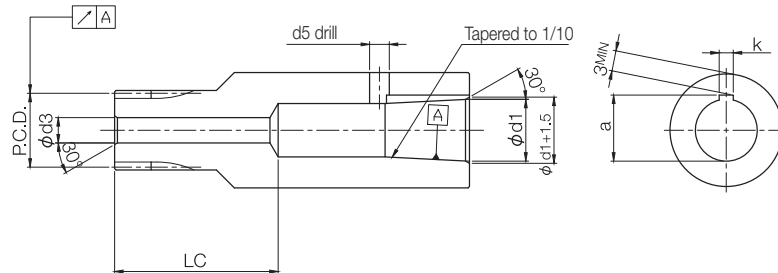

- Note 1. For the bolt through hole diameter ($d3$), radial runout, and the shaft hole position (LC), refer to “Dimensions after modification” in the “Dimensions” table on pages 107 and 108.
2. Design the motor shaft hole diameter ($d1$) according to the motor shaft diameter to be used.
 3. For the keyway width (k) and keyway height (a), refer to the specifications of the key to be used.
 4. There are two ways to fix the tapered shaft to the motor shaft: draw nut and draw bolt. Fix the shaft using either of them, referring to the drawings below.
 5. You can manufacture the draw nut and draw bolt on your own, or contact us.

• When fixing with a draw nut

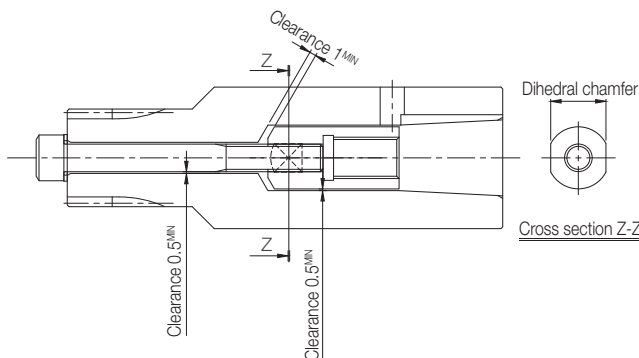

• When fixing with a draw bolt

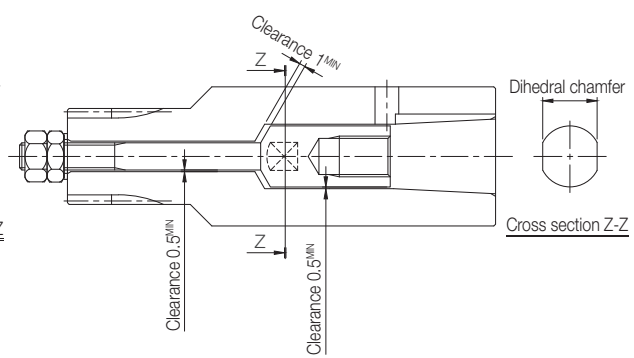

•Design of the oil seal area

<Design example 4>

If a lip surface is required for the oil seal, manufacture a new input gear and quench the D2 section, and then perform plunge grinding.

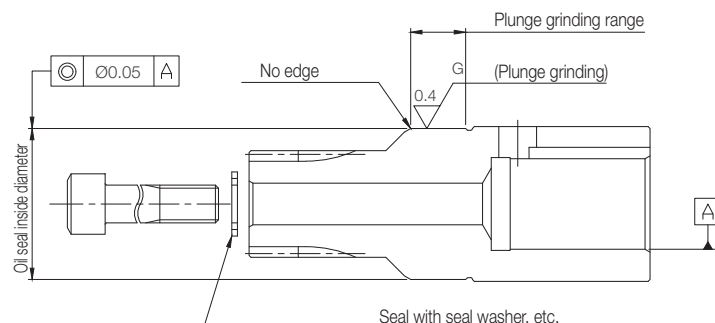

- Note 1. The design specifications vary depending on the oil seal manufacturer. When designing, be sure to confirm with the manufacturer of the oil seal to be used.
2. The standard input gear is not compatible with the oil seal surface. If the lip surface is required for the oil seal, manufacture a new input gear.
 3. Rubber containing fluorine is recommended for the material of the oil seal.
 4. When assembling the oil seal, be careful to avoid any contact between the lip section and the gear, as it causes scratches.
 5. Design the oil seal assembly position so that the lip section of the oil seal does not fall off from the plunge grinding range.

Dimensions of standard input gear

(Unit: mm)

<Model:
RV-6E >
(Unit: mm)

Ratio code	Dimensions before modification (when shipped)										Dimensions after modification				
	ØD3	LE	LD ^{+2.0} ₀	[Standard input gear A]			[Standard input gear B]				Ø d3 ^{MAX}	Radial runout	[Standard input gear A]	[Standard input gear B]	
				L	LA	Ød4	ØD2	L	LA	Ød5			ØD1	LC ^{MIN}	LC ^{MIN}
* 31	18	5	12	96	60	4.5	28	/				5.2	-	63	/
* 43		5	12	96	60	4.5						5.2	-	63	
53.5		5	6	90	54	4.5						8.5	0.047	57	
59		5	6	90	54	4.5						7.5	0.047	57	
79		5	6	90	54	4.5						5.5	0.050	57	
103		5	6	90	54	4.5						4.4	0.043	57	

(Unit: mm)

<Model:
RV-20E,
RV-15 >
(Unit: mm)

Ratio code	Dimensions before modification (when shipped)										Dimensions after modification				
	ØD3	LE	LD ^{+2.0} ₀	[Standard input gear A]			[Standard input gear B]				Ø d3 ^{MAX}	Radial runout	[Standard input gear A]	[Standard input gear B]	
				L	LA	Ød4	ØD2	L	LA	Ød5			ØD1	LC ^{MIN}	LC ^{MIN}
* 57	21.5	6	16	95	53	5.5	23.5	110	73	5.5	30	5.6	-	56	76
81		6	8	95	46	5.5		100	66	5.5		9.2	0.050	49	69
105		6	8	95	46	5.5		100	66	5.5		6.7	0.050	49	69
121		6	8	95	46	5.5		100	66	5.5		5.2	0.050	49	69
141		6	8	95	46	5.5		100	66	5.5		6.5	0.043	49	69
161		6	8	95	46	5.5		100	66	5.5		5.8	0.043	49	69

(Unit: mm)

<Model:
RV-40E,
RV-30 >
(Unit: mm)

Ratio code	Dimensions before modification (when shipped)										Dimensions after modification				
	ØD3	LE	LD ^{+2.0} ₀	[Standard input gear A]			[Standard input gear B]				Ø d3 ^{MAX}	Radial runout	[Standard input gear A]	[Standard input gear B]	
				L	LA	Ød4	ØD2	L	LA	Ød5			ØD1	LC ^{MIN}	LC ^{MIN}
* 57	26.5	7	15	105	58	6.8	29.5	120	81	6.8	36	7	-	61	84
81		7	10	100	53	7		115	76	6.6		14.5	0.050	56	79
105		7	10	100	53	7		115	76	6.6		9	0.053	56	79
121		7	10	100	53	7		115	76	6.6		9.7	0.050	56	79
153		7	10	100	53	7		115	76	6.6		6.7	0.050	56	79

(Unit: mm)

<Model:
RV-80E,
RV-60 >
(Unit: mm)

Ratio code	Dimensions before modification (when shipped)										Dimensions after modification				
	ØD3	LE	LD ^{+2.0} ₀	[Standard input gear A]			[Standard input gear B]				Ø d3 ^{MAX}	Radial runout	[Standard input gear A]	[Standard input gear B]	
				L	LA	Ød4	ØD2	L	LA	Ød5			ØD1	LC ^{MIN}	LC ^{MIN}
* 57	-	7	17	110	35	6.8	36	140	88	6.8	42	7	-	61.4	91
81		7	10	100	29	7		130	80	9		18.3	0.059	38.3	83
101		7	10	100	29	7		130	80	9		13	0.053	40	83
121		7	10	100	29	7		130	80	9		11.4	0.053	41.8	83
153		7	10	100	29	7		130	80	9		7.9	0.053	43.6	83

The ratio code marked with * indicates the dimensions of the standard input spline.
For the gear tooth specifications, refer to "Gear tooth specifications for each input spline model" on page 110.

Design Points

Input Gears

(Unit: mm)

<Model:
RV-110E >
(Unit: mm)

Ratio code	Dimensions before modification (when shipped)										Dimensions after modification				
	ØD3	LE	LD ^{+2.0} ₀	[Standard input gear A]			[Standard input gear B]				Ø d3 ^{MAX}	Radial runout	[Standard input gear A] LC ^{MIN}	[Standard input gear B] LC ^{MIN}	
				L	LA	Ød4	ØD2	L	LA	Ød5					ØD1
81	38	7	13	120	70	9	40	/				28.7	0.055	73	/
111		7	13	120	70	9						22.5	0.050	73	
161		7	13	120	70	9						17	0.050	73	
175.28		7	13	120	70	9						15.7	0.050	73	

(Unit: mm)

<Model:
RV-160E,
RV-160 >
(Unit: mm)

Ratio code	Dimensions before modification (when shipped)										Dimensions after modification				
	ØD3	LE	LD ^{+2.0} ₀	[Standard input gear A]			[Standard input gear B]				Ø d3 ^{MAX}	Radial runout	[Standard input gear A] LC ^{MIN}	[Standard input gear B] LC ^{MIN}	
				L	LA	Ød4	ØD2	L	LA	Ød5					ØD1
81	-	8	15	120	35	7	42	170	105	9	50	20.2	0.059	44.5	108
101		8	15	120	35	7		170	105	9		16.2	0.059	46.5	108
129		8	15	120	35	7		170	105	9		11.2	0.053	49	108
145		8	15	120	35	7		170	105	9		14.2	0.050	51.8	108
171		8	15	120	35	7		170	105	9		13.1	0.050	53.4	108

(Unit: mm)

<Model:
RV-320E,
RV-320 >
(Unit: mm)

Ratio code	Dimensions before modification (when shipped)										Dimensions after modification				
	ØD3	LE	LD ^{+2.0} ₀	[Standard input gear A]			[Standard input gear B]				Ø d3 ^{MAX}	Radial runout	[Standard input gear A] LC ^{MIN}	[Standard input gear B] LC ^{MIN}	
				L	LA	Ød4	ØD2	L	LA	Ød5					ØD1
81	-	11	16	140	35	11	46	185	122	11	50	29	0.059	45.6	125
101		11	16	140	35	11		185	122	11		25	0.059	47.6	125
118.5		11	16	140	35	11		185	122	11		21	0.059	49.6	125
129		11	16	140	35	11		185	122	11		19	0.059	50.6	125
141		11	16	140	35	11		185	122	11		17	0.059	51.6	125
171		11	16	140	35	11		185	122	11		13	0.053	53.6	125
185		11	16	140	35	11		185	122	11		14.2	0.050	55.1	125

(Unit: mm)

<Model:
RV-450E,
RV-450 >
(Unit: mm)

Ratio code	Dimensions before modification (when shipped)										Dimensions after modification				
	ØD3	LE	LD ^{+2.0} ₀	[Standard input gear A]			[Standard input gear B]				Ø d3 ^{MAX}	Radial runout	[Standard input gear A] LC ^{MIN}	[Standard input gear B] LC ^{MIN}	
				L	LA	Ød4	ØD2	L	LA	Ød5					ØD1
81	-	8	18	155	38	11	56	215	139	11	58	32.6	0.059	54.1	142
101		8	18	155	38	11		215	139	11		28.3	0.059	56.3	142
118.5		8	18	155	38	11		215	139	11		23.8	0.059	58.5	142
129		8	18	155	38	11		215	139	11		21.5	0.059	59.7	142
154.8		8	18	155	38	11		215	139	11		17.1	0.059	61.9	142
171		8	18	155	38	11		215	139	11		14.8	0.059	63	142
192.4		8	18	155	38	11		215	139	11		15.1	0.053	65	142

(Unit: mm)

<Model:
RV-550 >
(Unit: mm)

Ratio code	Dimensions before modification (when shipped)										Dimensions after modification				
	ØD3	LE	LD ^{+2.0} ₀	[Standard input gear A]			[Standard input gear B]				Ø d3 ^{MAX}	Radial runout	[Standard input gear A] LC ^{MIN}	[Standard input gear B] LC ^{MIN}	
				L	LA	Ød4	ØD2	L	LA	Ød5					ØD1
123	-	7	22	180	45	9	56	/				27.0	0.059	64.3	/
141		7	22	180	45	9						24.2	0.059	65.7	
163.5		7	22	180	45	9						20.2	0.059	67.7	
192.4		7	22	180	45	9						16.2	0.059	69.7	

Gear tooth specifications

Refer to the specifications and materials shown in the following tables when designing a system with a processed or non-standard input gear.

For a model or gear ratio other than those listed below, contact us.

Common specifications	
Tooth profile	Full depth
Pressure angle (°)	20
Precision	JIS B 1702: 1976 Grade 5

Spur gear tooth surface hardness and material	
Heat treatment	Carburizing, quenching and tempering
Surface hardness	HRC 56 to 62
Effective case depth <HV513> (mm)	0.3 to 0.7 *1
Material	SCM415 Normalizing
Alternate material	SCM420 Normalizing

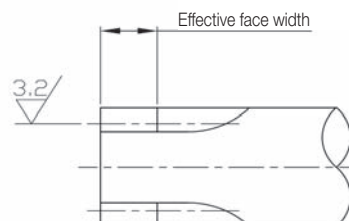

*1 The value will differ depending on the module.

Module	1 or lower	More than 1
Effective case depth <HV513> (mm)	0.2 to 0.6	0.3 to 0.7

Input gear tooth specifications for each model

Model	RV-6E					
Ratio code	31	43	53.5	59	79	103
Module	1	1.25	1	1	1.25	1
No. of teeth	22	15	16	15	10	10
Shift coefficient	+0.04	+0.25	+0.5	+0.5	+0.5	+0.5
Base tangent length(mm)	7.716 ^{-0.017} _{-0.042}	9.702 ^{-0.017} _{-0.042}	4.994 ^{-0.017} _{-0.042}	4.980 ^{-0.017} _{-0.042}	6.138 ^{-0.017} _{-0.042}	4.910 ^{-0.017} _{-0.042}
No. of teeth	(3)	(3)	(2)	(2)	(2)	(2)
Min. effective face width (mm)	6	6	6	6	6	6

Model	RV-20E, RV-15					
Ratio code	57	81	105	121	141	161
Module	1.5	1.5	1.5	1.5	1.0	0.9
No. of teeth	15	12	10	9	12	12
Shift coefficient	+0.2	+0.4	+0.5	+0.5	+0.5	+0.5
Base tangent length(mm)	7.163 ^{-0.017} _{-0.042}	7.305 ^{-0.017} _{-0.042}	7.365 ^{-0.017} _{-0.042}	7.344 ^{-0.017} _{-0.042}	7.890 ^{-0.017} _{-0.042}	7.101 ^{-0.017} _{-0.042}
No. of teeth	(2)	(2)	(2)	(2)	(3)	(3)
Min. effective face width (mm)	8	8	8	8	8	8

Model	RV-40E, RV-30				
Ratio code	57	81	105	121	153
Module	1.5	1.5	2.0	1.5	1.5
No. of teeth	20	16	10	12	10
Shift coefficient	0	+0.1	+0.5	+0.5	+0.5
Base tangent length(mm)	11.491 ^{-0.023} _{-0.061}	7.081 ^{-0.023} _{-0.061}	9.821 ^{-0.023} _{-0.061}	11.835 ^{-0.023} _{-0.061}	7.365 ^{-0.023} _{-0.061}
No. of teeth	(3)	(2)	(2)	(3)	(2)
Min. effective face width (mm)	10	10	10	10	10

Model	RV-80E, RV-60					
Ratio code	57	81 (for RV-60)	81 (for RV-80E)	101	121	153
Module	1.75	2.0	1.75	2.0	1.75	1.75
No. of teeth	20	14	16	12	12	10
Shift coefficient	0	+0.5	+0.5	+0.5	+0.5	+0.5
Base tangent length(mm)	13.406 ^{-0.028} _{-0.066}	15.837 ^{-0.028} _{-0.066}	13.906 ^{-0.028} _{-0.066}	15.781 ^{-0.028} _{-0.066}	13.808 ^{-0.028} _{-0.066}	8.593 ^{-0.028} _{-0.066}
No. of teeth	(3)	(3)	(3)	(3)	(3)	(2)
Min. effective face width (mm)	10	10	10	10	10	10

Model	RV-110E			
Ratio code	81	111	161	175.28
Module	1.25	1.25	1.25	1.25
No. of teeth	25	20	15	14
Shift coefficient	0	0	+0.3	+0.3
Base tangent length(mm)	9.663 ^{-0.028} _{-0.066}	9.576 ^{-0.028} _{-0.066}	9.746 ^{-0.028} _{-0.066}	9.727 ^{-0.028} _{-0.066}
No. of teeth	(3)	(3)	(3)	(3)
Min. effective face width (mm)	13	13	13	13

Design Points

Input Gears

Model	RV-160E, RV-160				
Ratio code	81	101	129	145	171
Module	2.5	2.5	2.5	1.5	1.25
No. of teeth	14	12	10	15	16
Shift coefficient	+0.3	+0.5	+0.5	+0.5	+0.5
Base tangent length(mm)	19.453 ^{-0.035} _{-0.085}	19.726 ^{-0.035} _{-0.085}	12.276 ^{-0.035} _{-0.085}	11.899 ^{-0.035} _{-0.085}	9.933 ^{-0.035} _{-0.085}
No. of teeth	(3)	(3)	(2)	(3)	(3)
Min. effective face width (mm)	15	15	15	15	15

Model	RV-320E, RV-320						
Ratio code	81	101	118.5	129	141	171	185
Module	2.0	2.0	2.0	2.0	2.0	2.0	1.5
No. of teeth	21	18	16	15	14	12	15
Shift coefficient	0	+0.5	+0.5	+0.5	+0.5	+0.5	+0.5
Base tangent length(mm)	15.349 ^{-0.035} _{-0.085}	15.949 ^{-0.035} _{-0.085}	15.893 ^{-0.035} _{-0.085}	15.865 ^{-0.035} _{-0.085}	9.933 ^{-0.035} _{-0.085}	15.781 ^{-0.035} _{-0.085}	11.899 ^{-0.035} _{-0.085}
No. of teeth	(3)	(3)	(3)	(3)	(2)	(3)	(3)
Min. effective face width (mm)	16	16	16	16	16	16	16

Model	RV-450E, RV-450						
Ratio code	81	101	118.5	129	154.8	171	192.4
Module	2.25	2.25	2.25	2.25	2.25	2.25	1.75
No. of teeth	21	18	16	15	13	12	14
Shift coefficient	0	+0.556	+0.556	+0.556	+0.556	+0.556	+0.572
Base tangent length(mm)	17.267 ^{-0.035} _{-0.085}	18.029 ^{-0.035} _{-0.085}	17.966 ^{-0.035} _{-0.085}	17.934 ^{-0.035} _{-0.085}	17.871 ^{-0.035} _{-0.085}	17.840 ^{-0.035} _{-0.085}	13.944 ^{-0.035} _{-0.085}
No. of teeth	(3)	(3)	(3)	(3)	(3)	(3)	(3)
Min. effective face width (mm)	18	18	18	18	18	18	18

Model	RV-550			
Ratio code	123	141	163.5	192.4
Module	2.0	2.0	2.0	2.0
No. of teeth	20	18	16	14
Shift coefficient	0	+0.3	+0.3	+0.3
Base tangent length(mm)	15.321 ^{-0.035} _{-0.085}	15.675 ^{-0.035} _{-0.085}	15.619 ^{-0.035} _{-0.085}	15.563 ^{-0.035} _{-0.085}
No. of teeth	(3)	(3)	(3)	(3)
Min. effective face width (mm)	22	22	22	22

Input gear tooth specifications for each model

Refer to the specifications shown in the following tables when designing with a processed or non-standard input spline. The specifications of the hardness and material are the same as those of the input gear.

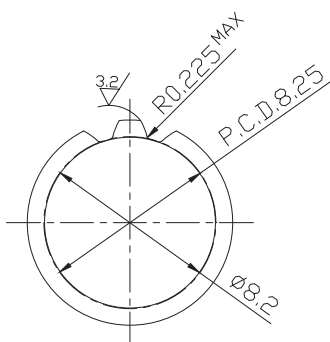

Detailed drawing of spline section

RV-6E		
Automotive involute spline (shaft) 10x11x0.75 (JIS D2001)		
Shift coefficient	+0.9667	
Tool	Tooth profile	Stub tooth
	Module	0.75
	Pressure angle	20°
No. of teeth	11	
Reference pitch diameter	8.25	
Face width	Over-pin diameter	11.120 ^{-0.011} _{-0.076}
	Pin diameter Ø1.4 (Pin diameter Ø1.5)	{ 11.380 ^{-0.011} _{-0.076} }
	Grade	b
Remarks	Side fit	

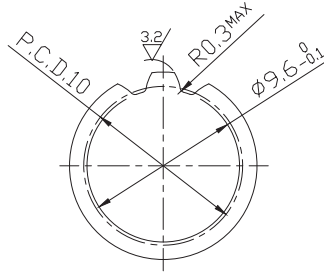

Detailed drawing of spline section

RV-20E		
Automotive involute spline (shaft) 12x10x1.0 (JIS D2001)		
Shift coefficient	+0.8	
Tool	Tooth profile	Stub tooth
	Module	1.0
	Pressure angle	20°
No. of teeth	10	
Reference pitch diameter	10	
Face width	Over-pin diameter	13.564 ^{-0.012} _{-0.078}
	Pin diameter Ø1.8 (Pin diameter Ø2.0)	{ 13.564 ^{-0.012} _{-0.078} }
	Grade	b
Remarks	Side fit	

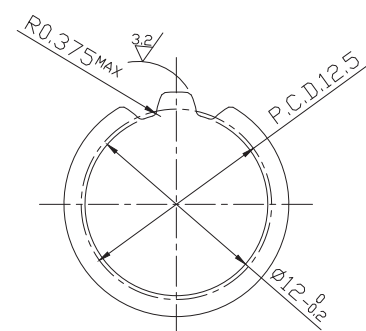

Detailed drawing of spline section

RV-40E, RV-80E		
Automotive involute spline (shaft) 15x10x1.25 (JIS D2001)		
Shift coefficient	+0.8	
Tool	Tooth profile	Stub tooth
	Module	1.25
	Pressure angle	20°
No. of teeth	10	
Reference pitch diameter	12.5	
Face width	Over-pin diameter	16.954 ^{-0.012} _{-0.078}
	Pin diameter Ø2.25 (Pin diameter Ø2.381)	{ 17.301 ^{-0.012} _{-0.078} }
	Grade	b
Remarks	Side fit	

Design Points

Lubricant VIGOGREASE®

Lubricant

The standard lubricant for RV precision reduction gears is grease.

In order to take advantage of the performance of RV precision reduction gears, we recommend that you use Nabtesco VIGOGREASE grease. VIGOGREASE was specifically developed for use with Nabtesco products and does not take into account the use with products from other companies.

It is therefore recommended that you refrain from using VIGOGREASE with products from any other company.

Should for any reason it be necessary to use VIGOGREASE with another company's product, Nabtesco assumes no responsibility whatsoever for any breakdown, malfunction, or other trouble such as with the corresponding reduction gear, the equipment or system it is used in.

In such cases, it should also be understood that Nabtesco cannot comply with any request to inspect the quality of the corresponding grease, etc.

<Approved lubricant brand (standard specified brand)>

Grease	
Nabtesco	VIGOGREASE RE0

Note: Do not mix with other lubricants.

Amount of lubricant

RV precision reduction gears are not applied with lubricant when shipped. Be sure to design your equipment so that the necessary amount of our authorized lubricant can be applied. (When pneumatic pressure is used for applying the lubricant, set the pressure below 0.03 MPa.)

For the E series and Original series

The amount of lubricant required for the reduction gear and the target range (the ■■■■ areas in the diagram) when the reduction gear is installed in the horizontal shaft are indicated in Fig. 1 and when the reduction gear is installed in the vertical shaft are indicated in Fig. 2. Each amount does not include the space (the ▨▨▨▨ areas in the diagram) on the motor mounting side. Therefore, if there is a blank space, also fill the space. Leave a space about 10% of the total volume of the internal capacity of the reduction gear (the ■■■■ areas in the diagram) and the space on the motor mounting side (the ▨▨▨▨ areas in the diagram).

<Horizontal shaft installation>

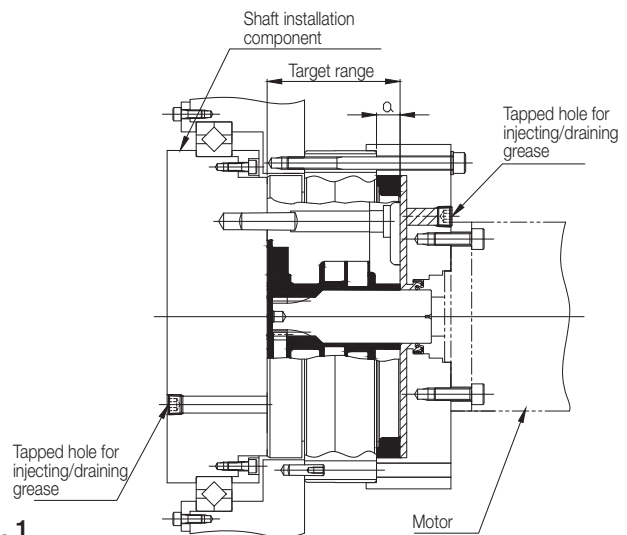
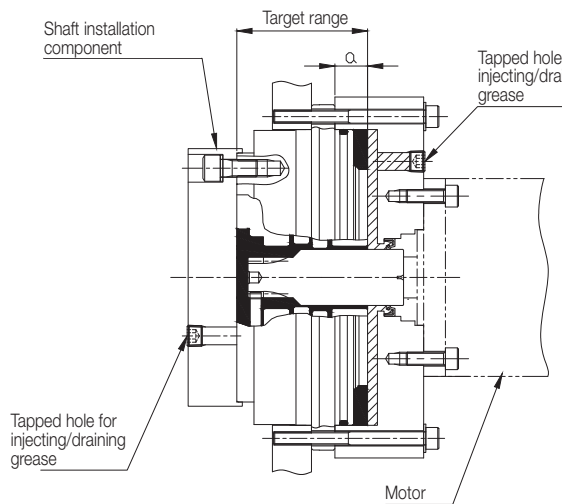

Fig. 1

E series

Model	Required amount		Dimensions a (mm)
	(cc)	(g)*1	
RV-6E	42	(38)	17
RV-20E	87	(78)	15
RV-40E	195	(176)	21
RV-80E(1)*2	383	(345)	21
RV-80E(2)*2	345	(311)	21
RV-110E	432	(389)	6.5
RV-160E	630	(567)	10.5
RV-320E	1,040	(936)	15.5
RV-450E	1,596	(1,436)	18

Original series

Model	Required amount		Dimensions a (mm)
	(cc)	(g)*1	
RV-15	88	(79)	17
RV-30	162	(146)	15.5
RV-60	258	(232)	10.5
RV-160	448	(403)	17
RV-320	884	(796)	21.6
RV-450	1,453	(1,308)	21
RV-550	1,967	(1,770)	24

*1. Density of VIGOGREASE RE0: 0.9 g/cc

*2. (1) indicates the amount of lubricant for the bolt-clamping output shaft type, and (2) for the pin/bolt clamping output shaft type.

Design Points

Lubricant VIGOGREASE®

<Vertical shaft installation (with shaft facing upward)>

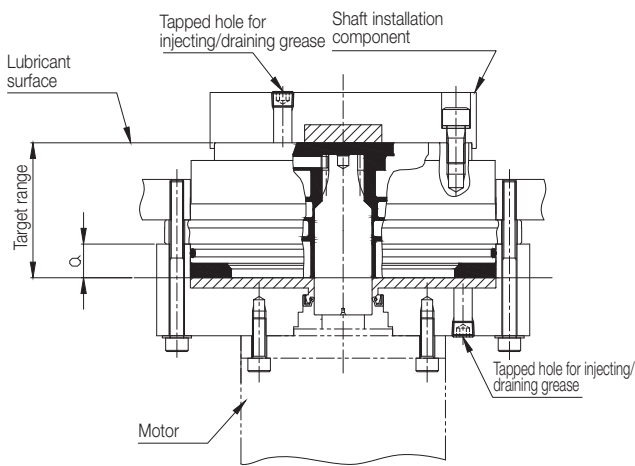

E series

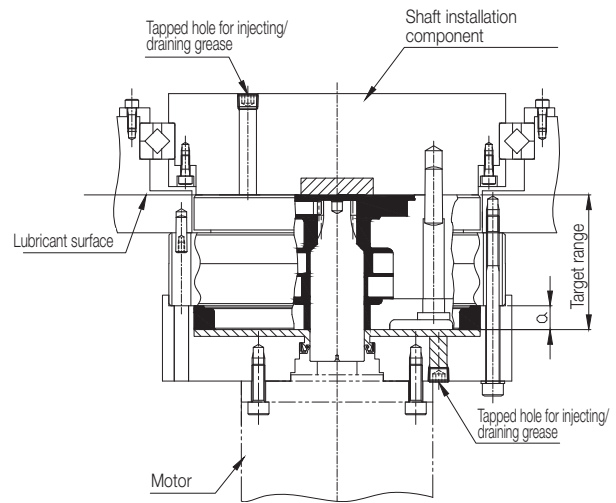

Original series

<Vertical shaft installation (with shaft facing downward)>

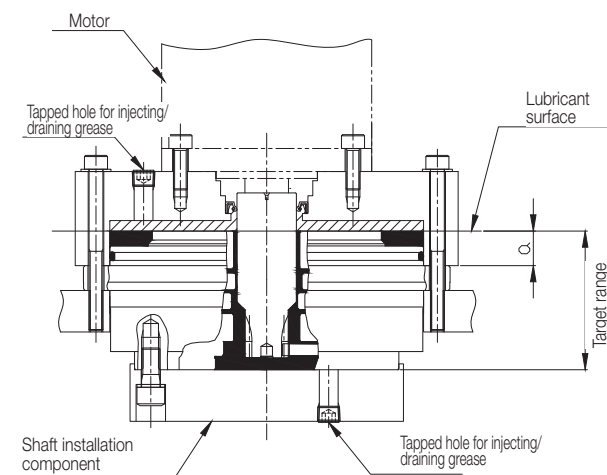

E series

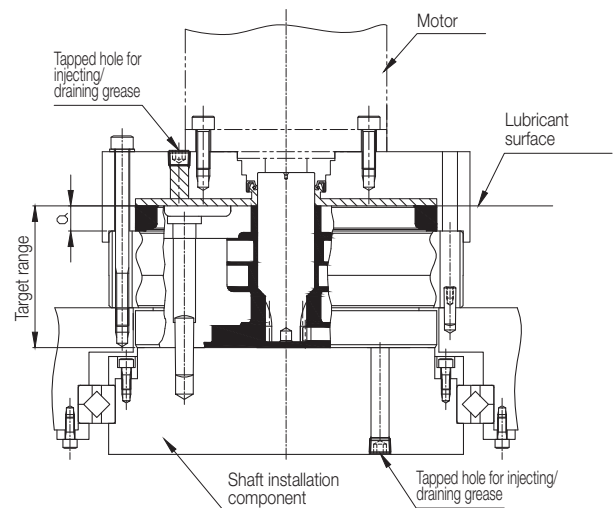

Original series

Fig. 2







Model	Required amount		Dimensions a (mm)
	(cc)	(g) ^{*1}	
RV-6E	48	(43)	17
RV-20E	100	(90)	15
RV-40E	224	(202)	21
RV-80E(1) ^{*2}	439	(395)	21
RV-80E(2) ^{*2}	396	(356)	21
RV-110E	495	(446)	6.5
RV-160E	694	(625)	10.5
RV-320E	1,193	(1,074)	15.5
RV-450E	1,831	(1,648)	18

Model	Required amount		Dimensions a (mm)
	(cc)	(g) ^{*1}	
RV-15	101	(91)	17
RV-30	186	(167)	15.5
RV-60	296	(266)	10.5
RV-160	514	(463)	17
RV-320	1,014	(913)	21.6
RV-450	1,663	(1,497)	21
RV-550	2,257	(2,031)	24

*1. Density of VIGOGREASE RE0: 0.9 g/cc

*2. (1) indicates the amount of lubricant for the bolt-clamping output shaft type, and (2) for the pin/bolt clamping output shaft type.

For the C series

The amount of lubricant required for the reduction gear and the target range (the  areas in the diagram) when the reduction gear is installed in the horizontal shaft are indicated in Fig. 3 and when the reduction gear is installed in the vertical shaft are indicated in Fig. 4. If there is a blank space inside (e.g., when a center tube is used), exclude the volume of the blank space. Each amount does not include the space (the  areas in the diagram) on the motor mounting side. Therefore, if there is a blank space, also fill the space. Leave a space about 10% of the total volume of the internal capacity of the reduction gear (the  areas in the diagram) and the space on the motor mounting side (the  areas in the diagram). The space on the motor mounting side (the  areas in the diagram) includes the center gear external capacity (the  areas in the diagram) and the external capacity of the reduction gear (the  areas in the diagram). Therefore, when calculating the volume of the space on the motor mounting side, exclude the relevant external capacity.

Model	Required amount		Dimensions a (mm)	Dimensions b (mm)	Reduction gear external capacity(cc)	Center gear external capacity (cc)
	(cc)	(g) ^{*1}				
RV-10C	147	(132)	9.5	16.85	4	70
RV-27C	266	(239)	10	21.35	10	83
RV-50C	498	(448)	11	23.35	21	208
RV-100C	756	(680)	9.9	29.45	57	369
RV-200C	1,831	(1,648)	18.5	37.7	93	642
RV-320C	3,536	(3,182)	25	46.75	197	1,275
RV-500C	5,934	(5,341)	32	49.7	310	1,803

<Horizontal shaft installation>

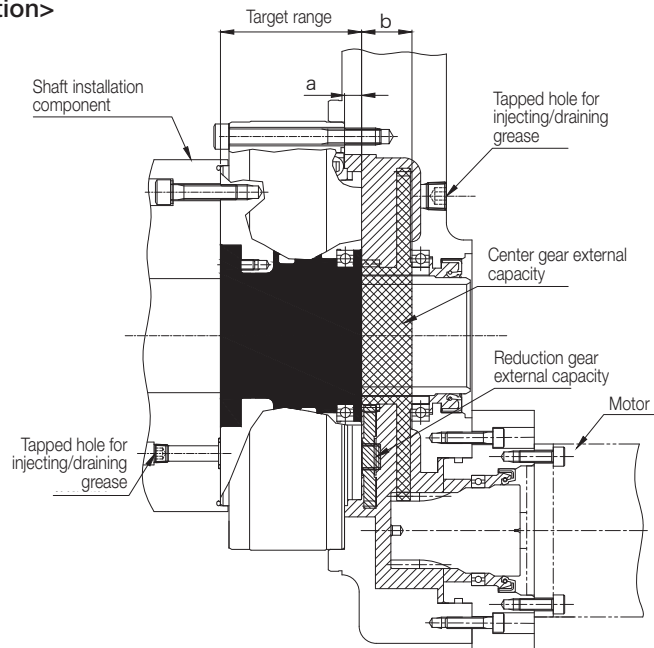
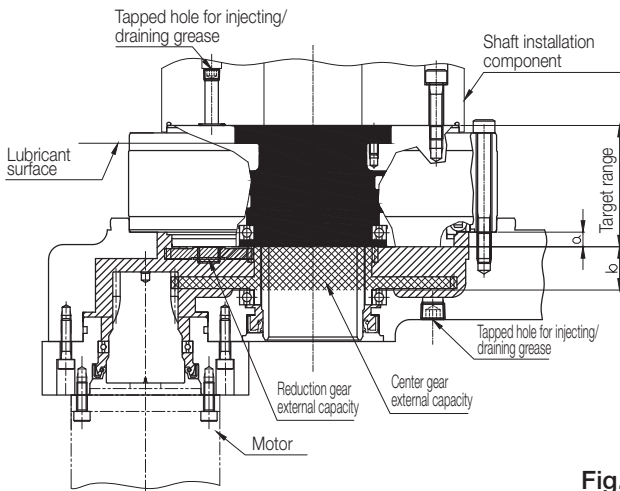

Fig. 3

Design Points

Lubricant VIGOGREASE®

<Vertical shaft installation (with shaft facing upward)>



<Vertical shaft installation (with shaft facing downward)>

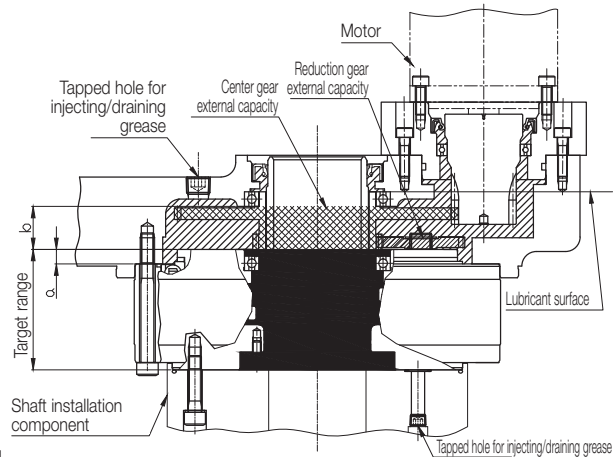



Fig. 4

Model	Required amount		Dimensions a (mm)	Dimensions b (mm)	Reduction gear external capacity (cc)	Center gear external capacity (cc)
	(cc)	(g)*1				
RV-10C	167	(150)	9.5	16.85	4	70
RV-27C	305	(275)	10	21.35	10	83
RV-50C	571	(514)	11	23.35	21	208
RV-100C	857	(771)	9.9	29.45	57	369
RV-200C	2,076	(1,868)	18.5	37.7	93	642
RV-320C	4,047	(3,642)	25	46.75	197	1,275
RV-500C	6,900	(6,210)	32	49.7	310	1,803

*1. Density of VIGOGREASE RE0: 0.9 g/cc

Grease replacement time

During proper operation of the reduction gear, the standard grease replacement time due to lubricant degradation is 20,000 hours.

However, when operation involves a reduction gear surface temperature above 40°C (the  area in the right diagram), the state of the lubricant should be checked in advance and the grease replaced earlier as necessary.

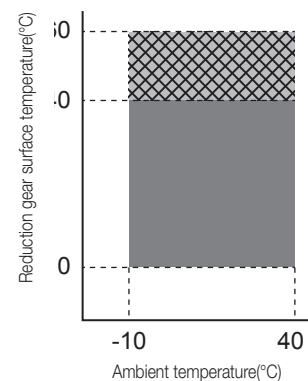

Running-in operation

It is recommended that the running-in operation is performed after the Nabtesco-specified lubricant is added. Abnormal noise or torque irregularity may occur during operation, depending on the characteristics of the lubricant. There is no problem with the quality when the symptom disappears after the running-in operation is performed for 30 minutes or more (until the surface temperature of the reduction gear body reaches around 50°C).

Inertia Moment Calculation Formula

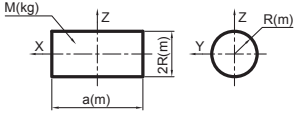
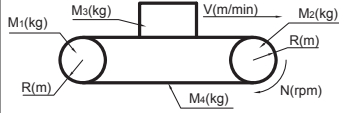
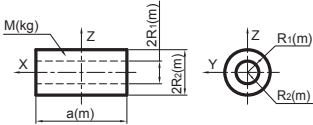
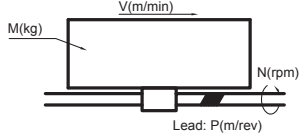
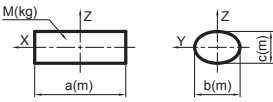
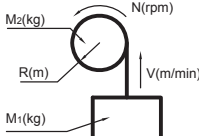
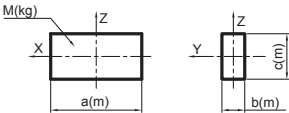
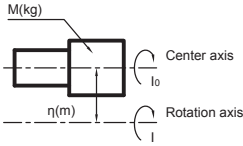
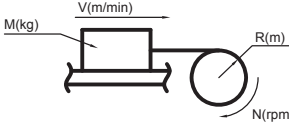
Shape	I(kgm ²)	Shape	I(kgm ²)
<p>1. Cylinder solid</p> 	$I_x = \frac{1}{2} MR^2$ $I_y = \frac{1}{4} M \left(R^2 + \frac{a^2}{3} \right)$ $I_z = I_y$	<p>6. Horizontal movement by conveyor</p> 	$I = \left(\frac{M_1 + M_2}{2} + M_3 + M_4 \right) \times R^2$
<p>2. Cylinder hollow</p> 	$I_x = \frac{1}{2} M (R_1^2 + R_2^2)$ $I_y = \frac{1}{4} M \left\{ (R_1^2 + R_2^2) + \frac{a^2}{3} \right\}$ $I_z = I_y$	<p>7. Horizontal movement by lead screw</p> 	$I = \frac{M}{4} \left(\frac{V}{\pi \times N} \right)^2 = \frac{M}{4} \left(\frac{P}{\pi} \right)^2$
<p>3. Oval cross section</p> 	$I_x = \frac{1}{16} M (b^2 + c^2)$ $I_y = \frac{1}{4} M \left(\frac{c^2}{4} + \frac{a^2}{3} \right)$ $I_z = \frac{1}{4} M \left(\frac{b^2}{4} + \frac{a^2}{3} \right)$	<p>8. Up/down movement by hoist</p> 	$I = M_1 R^2 + \frac{1}{2} M_2 R^2$
<p>4. Rectangle</p> 	$I_x = \frac{1}{12} M (b^2 + c^2)$ $I_y = \frac{1}{12} M (a^2 + c^2)$ $I_z = \frac{1}{12} M (a^2 + b^2)$	<p>9. Parallel axis theorem</p> 	$I = I_0 + M \eta^2$ <p>I_0 : Moment of inertia of any object about an axis through its center of mass</p> <p>I : Moment of inertia about any axis parallel to the axis through its center of mass</p> <p>η : Perpendicular distance between the above two axes</p>
<p>5. General application</p> 	$I = \frac{M}{4} \left(\frac{V}{\pi \times N} \right)^2 = MR^2$		

Troubleshooting Checklist

Check the following items in the case of trouble like abnormal noise, vibration, or malfunctions.

When it is not possible to resolve an abnormality even after verifying the corresponding checkpoint, obtain a "Reduction Gear Investigation Request Sheet" from the download page in our Website, fill in the necessary information, and contact our Customer Support Center at Tsu Plant.

[URL]: <http://precision.nabtesco.com/>

The trouble started immediately after installation of the reduction gear

Checked	Checkpoint
	Make sure the equipment's drive section (the motor side or the reduction gear output surface side) is not interfering with another component.
	Make sure the equipment is not under a greater than expected load (torque, moment load, thrust load).
	Make sure the required number of bolts are tightened uniformly with the specified tightening torque.
	Make sure the reduction gear, motor, or your company's components are not installed at a slant.
	Make sure the specified amount of Nabtesco-specified lubricant has been added.
	Make sure there are no problems with the motor's parameter settings.
	Make sure there are no components resonating in unity.
	Make sure the input gear is appropriately installed on the motor.
	Make sure there is no damage to the surface of the input gear teeth.
	Make sure the input gear specifications (precision, number of teeth, module, shift coefficient, dimensions of each part) are correct.
	Make sure the flange and other components are designed and manufactured with the correct tolerances.

The trouble started during operation

Checked	Checkpoint
	Make sure the equipment has not been in operation longer than the calculated service life.
	Make sure the surface temperature of the reduction gear is not higher than normal during operation.
	Make sure the operation conditions have not been changed.
	Make sure there are no loose or missing bolts.
	Make sure the equipment is not under a greater than expected load (torque, moment load, thrust load).
	Make sure the equipment's drive section is not interfering with another component.
	Make sure an oil leak is not causing a drop in the amount of lubricant.
	Make sure there are no external contaminants in the gear, such as moisture or metal powder.
	Make sure no lubricant other than that specified is being used.

APPLICATION WORKSHEET

Please supply us the following items when ordering RV series Reduction Gears.

1. How used

Name of Machine: _____

Applied to: _____

2. Model RV-

3. Conditions of load

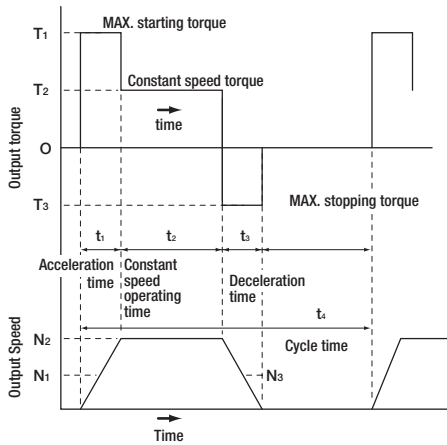

	For starting (MAX)	For constant speed	For stopping (MAX)	Cycle time
Load torque (Nm)	T_1	T_2	T_3	_____
Speed (rpm)	N_1	N_2	N_3	_____
Time (s)	t_1	t_2	t_3	t_4

Working hours Cycle/Day: Day/Year: Year

4. External load conditions

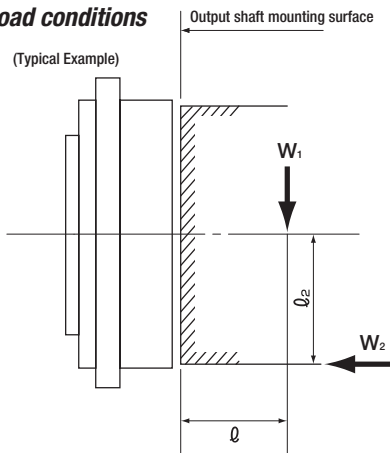

(W_1): _____ (N) (l): _____ (N)

(W_2): _____ (N) (l_2): _____ (N)

5. Operating environment

Operating environment temperature _____°C

6. Installation

Horizontal Vertical (Upper motor
 Lower Motor)

Illustration for installation

7. Input gear specification

Reduction speed ratio: $i=$ _____

Standard size, Other

Input gear Prepared by User TS Corporation

Required dimension of input gear (Illustration)

8. Driving portion (Servo motor)

Manufacturer Model (_____)

Capacity: _____ (kW)

Rated torque: _____ (Nm)

Speed: _____ (rpm)

Shape of the shaft _____ (mm)

9. Other

(_____)

VIGOGREASE® Ordering Information

Application and features

This product is a lubricant specially made for Nabtesco precision reduction gears and can achieve high efficiency and extended service life for our reduction gears.

Package

Select from among the following container sizes.

Package	Part number	Style of packing
2kg	VIGOG-RE0-2KG	Can (in cardboard box)
16kg	VIGOG-RE0-16KG	Pail
170kg	VIGOG-RE0-170KG	Drum

Caution

Be sure to use this product only after fully and carefully reading the cautions, etc., on the container.

Contact Information

Asia and others (Customer Support Center, Tsu Plant, Nabtesco Corporation)

Phone: +81-59-237-4672 FAX: +81-59-237-4697

Europe & Africa (Nabtesco Precision Europe GmbH)

Phone: +49-211-173790 FAX: +49-211-364677

E-mail: info@nabtesco-precision.de

North & South America (Nabtesco Motion Control, Inc.)

Phone: +1-248-553-3020 FAX: +1-248-553-3070

E-mail: info@nabtescomotioncontrol.com

China (Shanghai Nabtesco Motion-equipment Trading Co., Ltd.)

Phone: +86-21-33632200 FAX: +86-21-33632655

E-mail: info@nabtesco-motion.cn

Warranty

1. In the case where Nabtesco confirms that a defect of the Product was caused due to Nabtesco's design or manufacture within the Warranty Period of the Product, Nabtesco shall repair or replace such defective Product at its cost. The Warranty Period shall be from the delivery of the Product by Nabtesco or its distributor to you ("Customer") until the end of one (1) year thereafter, or the end of two thousand (2,000) hours from the initial operation of Customer's equipment incorporating the Product at end user's production line, whichever comes earlier.
 2. Unless otherwise expressly agreed between the parties in writing, the warranty obligations for the Product shall be limited to the repair or replacement set forth herein. OTHER THAN AS PROVIDED HEREIN, THERE ARE NO WARRANTIES ON THE PRODUCT, EXPRESS OR IMPLIED, INCLUDING WITHOUT LIMITATION ANY IMPLIED WARRANTY OF MERCHANTABILITY OR FITNESS FOR A PARTICULAR PURPOSE.
 3. The warranty obligation under the Section 1 above shall not apply if:
 - a) the defect was caused due to the use of the Product deviated from the Specifications or the working conditions provided by Nabtesco;
 - b) the defect was caused due to exposure to foreign substances or contamination (dirt, sand etc.)
 - c) lubricant or spare part other than the ones recommended by Nabtesco was used in the Product;
 - d) the Product was used in an unusual environment (such as high temperature, high humidity, a lot of dust, corrosive/volatile/inflammable gas, pressurized/depressurized air, under water/liquid or others except for those expressly stated in the Specifications);
 - e) the Product was disassembled, re-assembled, repaired or modified by anyone other than Nabtesco;
 - f) the defect was caused due to the equipment into which the Product was installed;
 - g) the defect was caused due to an accident such as fire, earthquake, lightning, flood or others; or
 - h) the defect was due to any cause other than the design or manufacturing of the Product.
 4. The warranty period for the repaired/replaced Product/part under the Section 1 above shall be the rest of the initial Warranty Period of the defective Product subjected to such repair/replace.
-

Nabtesco

Nabtesco Corporation

Europe and Africa

Nabtesco Precision Europe GmbH

Tiefenbroicher Weg 15, 40472 Düsseldorf, Germany
TEL: +49-211-173790 FAX: +49-211-364677
E-MAIL: info@nabtesco.de www.nabtesco.de



North and South America

Nabtesco Motion Control Inc.

23976 Freeway Park Drive, Farmington Hills, MI 48335, USA
TEL: +1-248-553-3020 FAX: +1-248-553-3070
E-MAIL: engineer@nabtescomotioncontrol.com www.nabtescomotioncontrol.com



China

Shanghai Nabtesco Motion-equipment Co., Ltd.

Room 1706, No. 388 Fu Shan Road, Pudong New Area, Shanghai 200122, China
TEL: +86-21-3363-2200 FAX: +86-21-3363-2655
E-MAIL: info@nabtesco-motion.cn www.nabtesco-motion.cn



India

Nabtesco India Private Limited

No. 506, Prestige Meridian - II No.30/8, M.G. Road, Bangalore-560 001 India
TEL: +91-80-4123-4901 FAX: +91-80-4123-4903

Asia and others

Nabtesco Corporation Nagoya Office

9th Fl. Nagoya 2nd Saitama Bldg., 2-28 Meieki 4-chome, Nakamura-ku, Nagoya 450-0002, Japan
TEL: +81-52-582-2981 FAX: +81-52-582-2987



Customer Support Center

594 Icchoda, Katada-cho, Tsu, Mie 514-8533, Japan
TEL: +81-59-237-4672 FAX: +81-59-237-4697

E-MAIL: P_Information@nabtesco.com <http://precision.nabtesco.com/>

- Nabtesco, VIGOGREASE, RV are registered trademarks or trademarks of Nabtesco Corporation.
- Specifications are subject to change without notice.
- The PDF data of this catalog can be downloaded from the following website.
<http://precision.nabtesco.com/>
If any addition or modification is made to the published information, the PDF data may be updated before the printed catalog.
Due to this, please note that some contents of the PDF data may be changed or revised from those in this catalog.
- Unauthorized reprinting, reproduction, copying, or translation of this catalog in whole or in part is strictly prohibited.

In-Position Technologies

www.iptech1.com | (877) 478-3241 | help@iptech1.com