

## KEY FEATURES

- ✓ Gripper with F/T sensors at the fingertips
- ✓ Integrated proximity sensor for part detect and centring
- ✓ Detects risk of slipping before it happens
- ✓ Precise and simple depth compensation
- ✓ Integrated force-controlled insertion software
- ✓ Force/Torque sensor for enabling precise machine tending, assembly jobs and collaborative operations

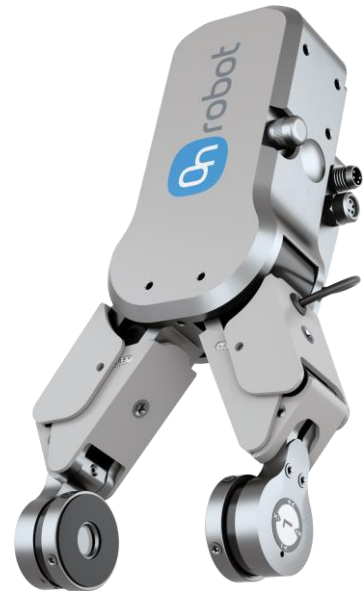

## TECHNICAL SPECIFICATIONS

<b>RG2-FT general properties</b>	<b>Min</b>	<b>Typical</b>	<b>Max</b>	<b>Units</b>
Total stroke (adjustable)	0	-	100	[mm]
Finger position resolution	-	0,1	-	[mm]
Gripping force (adjustable)	3	-	40	[N]
Reversing backlash	0,2	0,4	0,6	[mm]
Ambient operating temperature	5	-	50	[°C]
Product weight	-	0.77	-	[Kg]
Power consumption	6.5	-	22	[W]

<b>Force sensor properties</b>	<b>Fxy</b>	<b>Fz</b>	<b>Txy</b>	<b>Tz</b>
Nominal capacity (N.C.)	20 N	40 N	0.7 Nm	0.5 Nm
Noise free resolution	0.1 N	0.4 N	0.008 Nm	0.005 Nm
Single axis deformation at N.C.	0.4 mm	0.1 mm	2°	5°

<b>Proximity measurement properties</b>	<b>Min</b>	<b>Typical</b>	<b>Max</b>	<b>Units</b>
Sensing range	0	-	100	[mm]
Precision	-	2	-	[mm]
Non-linearity*	-	12	-	[%]

\* the non-linearity depends on the object properties (e.g. surface type and color)

## MECHANICAL DIMENSIONS

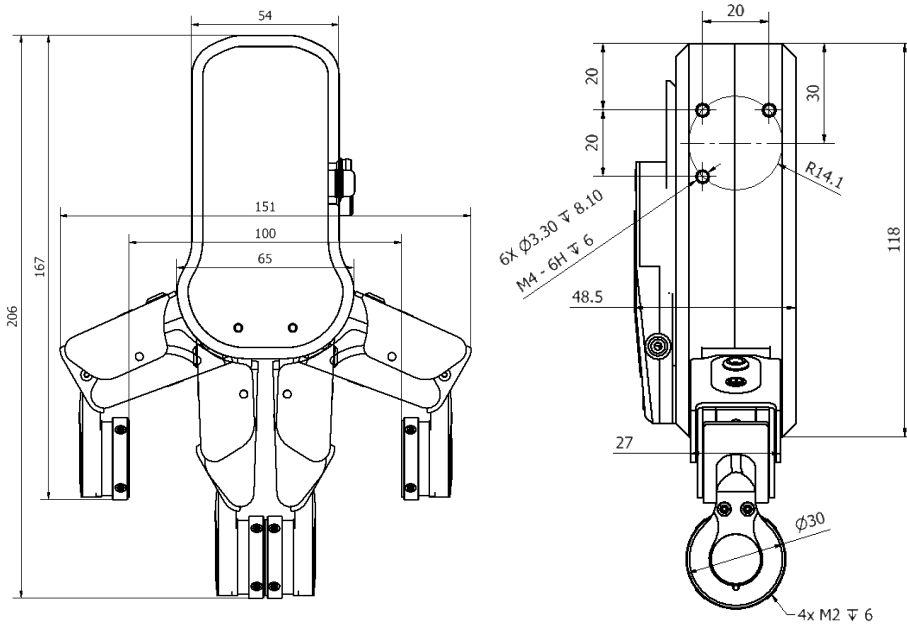

## GRIPPER WORKING RANGE

