

KEY FEATURES

- ✓ No external cables
- ✓ Adjustable gripper mounting
- ✓ Gripping feedback
- ✓ Automatic payload and TPC calculation
- ✓ Depth compensation
- ✓ Customizable fingertips



TECHNICAL SPECIFICATIONS

Technical data	Min	Typical	Max	Units
Total stroke (adjustable)	0	-	160	[mm]
Finger position resolution	-	0,15	-	[mm]
Repetition accuracy	-	0,15	0,3	[mm]
Reversing backlash	0,4	0,7	1	[mm]
Gripping force (adjustable)	25	-	120	[N]
Gripping force accuracy	± 2	± 5	± 10	[N]
Operating voltage*	10	24	26	[V DC]
Power consumption	1,9	-	14,4	[W]
Maximum Current	25	-	600	[mA]
Ambient operating temperature	5	-	50	[°C]
Storage temperature	0	-	60	[°C]
Product weight	-	1	-	[kg]

*At 12V the gripper runs at approximately half the normal speed

MECHANICAL DIMENSIONS

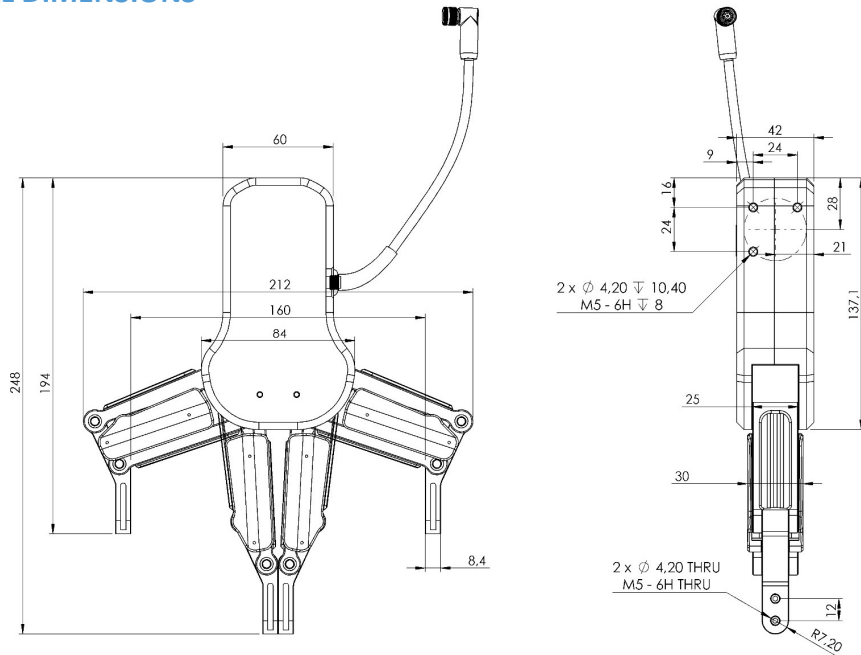

GRIPPER WORKING RANGE

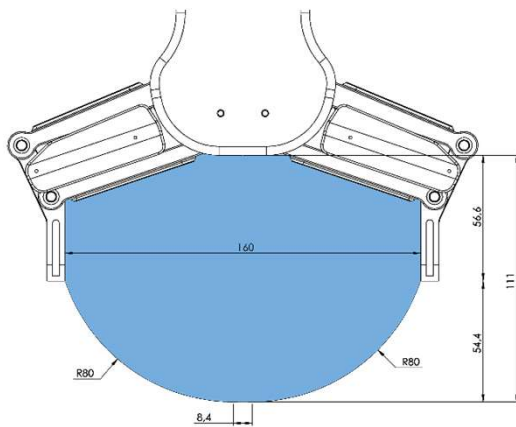

External Grip

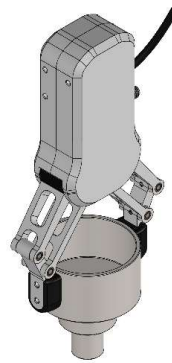

Internal Grip

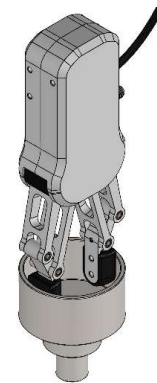

Fingertips are rotated.

TOOL CONNECTOR PINOUT

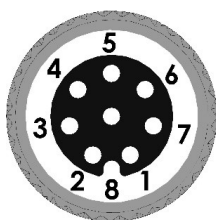

M8x1 cable, 8-pos

Pin	Wire	UR I/O	UR I/O V3
1	White	AI2	Tool analog input 2
2	Brown	AI3	Tool analog input 3
3	Green	DI9	Tool input 1
4	Yellow	DI8	Tool input 0
5	Gray	Power	24V DC
6	Pink	DO9	Tool output 1
7	Blue	DO8	Tool output 0
8	Red	GND	0V DC