

Harmonic Planetary[®]

In-Position
Technologies
www.iptech1.com

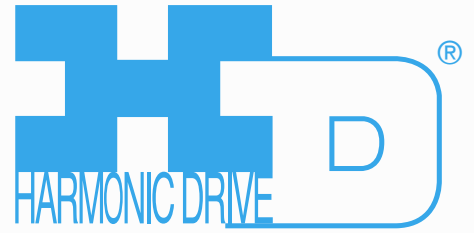

High-Performance, Face-Mount Gearheads for Servo and Stepper Motors

HPN-L Series



Revolutionary Technology for Evolving Industries

Harmonic Drive LLC engineers and manufactures precision servo actuators, gearheads and gear component sets. We work with industry-leading customers and companies of all sizes to provide both standard product and custom-engineered solutions to meet their mission critical application requirements. The majority of the products sold by HDLLC are proudly made at our US headquarters and manufacturing facility in Massachusetts. Affiliated companies in Japan (Harmonic Drive Systems, Inc.) and Germany (Harmonic Drive AG) provide additional manufacturing capabilities.

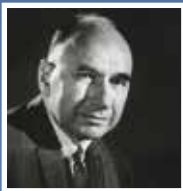

1955

Walt Musser's Patent Application for Strain Wave Gearing

1963

Harmonic Drive® components used in inertial damping system for an unmanned helicopter



Photo credit: NASA

1971

Lunar Rover was first driven on the moon by Dave Scott. Each of the Rover's wheels were driven by a Hermetically Sealed Harmonic Drive® actuator

1977

Developed first mechatronic products (Servo Actuators) combining Harmonic Drive® gearing with servo motors and feedback sensors



1986

First use of Harmonic Drive® gear used in semiconductor wafer handling robot

1988

"S" Tooth Profile was patented providing double the torque, double the life and double the stiffness









1990

Began production of planetary gears

With over 50 years of experience, our expert engineering and production teams continually develop enabling technologies for the evolving motion control market. We are proud of our outstanding engineering capabilities and successful history of providing customer specific solutions to meet their application requirements.

Our high-precision, zero-backlash Harmonic Drive® gears and Harmonic Planetary® gears play critical roles in robotics, spaceflight applications, semiconductor manufacturing equipment, factory automation equipment, medical diagnostics and surgical robotics.

						
1998	1999	2004	2004	2011	2015	2018
Market introduction of high-precision HPG Harmonic Planetary® gearheads with low backlash for life	Ultra-flat Harmonic Drive® gearing developed	Mars Exploration Rover Opportunity began a 90-day mission to explore the surface of Mars. 10* years later it is still operating and making new discoveries	Market introduction of the CSG high torque Harmonic Drive® gear with increased torque capacity and life	Robonaut 2 launches on STS-133 and becomes the first permanent robotic crew member of the International Space Station	2015 DARPA Robotics Challenge	Market introduction of HPN-L Harmonic Planetary® Gearheads

Industry Standard Face-Mount Helical Planetary Gearheads for Servo Grade Performance

High Accuracy, High Torsional Stiffness, Long Life

Precision Harmonic Planetary® gearheads offer high performance for servomotors with a wide range of available gear ratios and torque capacities.

Building a high precision actuator can be easily achieved by coupling a servomotor to one of our HPN-L Quick Connect® gearheads.

You can create a high precision actuator by connecting any manufacturer's servomotor to our precision gearhead with our Quick Connect® coupling.

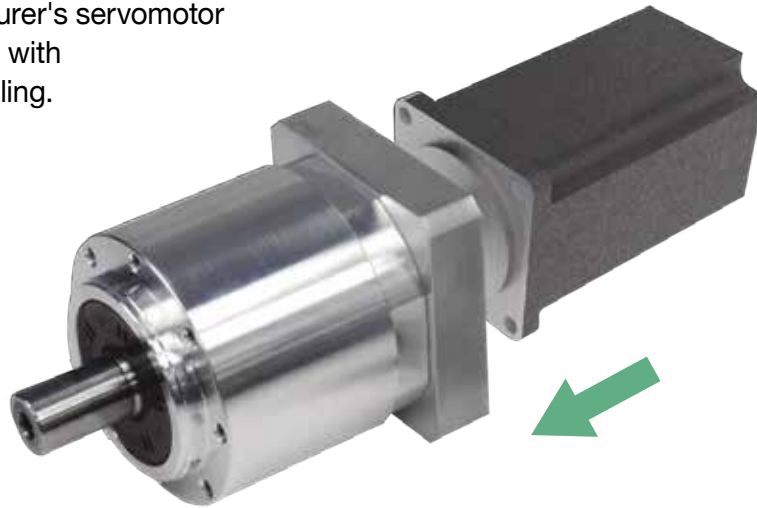

HarmonicPlanetary®
HPN-L Standard Series
(Peak torque 18Nm to 300Nm)



Size	Outline Dimension (mm)	Reduction ratio *1	Backlash		Motor power
			One stage	Two stage	
14	Ø60	3, 4, 5, 7, 10, 15, 20, 25, 30, 35, 40, 45, 50	≤ 5 arc-min	≤ 7 arc-min	100W ~ 600W
20	Ø90				200W ~ 2kW
32	Ø115				400W ~ 7kW

*1 One stage reduction ratio - 3, 4, 5, 7, 10, two stage reduction ratio - 15, 20, 25, 30, 35, 40, 45, 50.

HarmonicPlanetary® HPN Face-Mount Series

Size

14, 20, 32

3

Sizes

Peak Torque

18Nm ~ 300Nm

Reduction Ratio

Single stage: 3:1 to 10:1, Two stage: 15:1 to 50:1

Backlash

Single stage: < 5 arc-min, Two stage: < 7 arc-min

High Efficiency

Up to 97%

Output Bearing System

Output shaft supported by dual radial ball bearing system. The two bearings straddle the planet carrier maximizing tilting moment capacity.

Easy mounting to a wide variety of servomotors

Quick Connect® motor adaptation system includes a clamshell style servo coupling and piloted adapter flange.



CONTENTS

Rating, Performance Table	9-10
Outline Dimensions	11-13
Product Sizing & Selection	14-15
Efficiency	17
Output Shaft Bearing Load Limits	20
Assembly	21
Lubrication	22
Warranty	23
Safety	24

HPN-L Series
High-Performance Gearhead for Servomotors

HPN - 14 - L - 05 - Z - J6 - Motor Code

Model Name	Size	Design Revision	Reduction Ratio	Input Side Bearing	Output Configuration	Input Configuration
HarmonicPlanetary® HPN High Torque	14	L	3, 4, 5, 7, 10, 15, 20, 25, 30, 35, 40, 45, 50	Z: Input side bearing with double non-contact shields D: Input side bearing with double contact seals. (Recommended for output shaft up orientation.)	J6: Shaft output with key and center tapped hole J8: Shaft output with center tapped hole	This code represents the motor mounting configuration. Please contact us for a unique part number based on the motor you are using.
	20					
	32					

Gearhead Construction

Figure 05-1

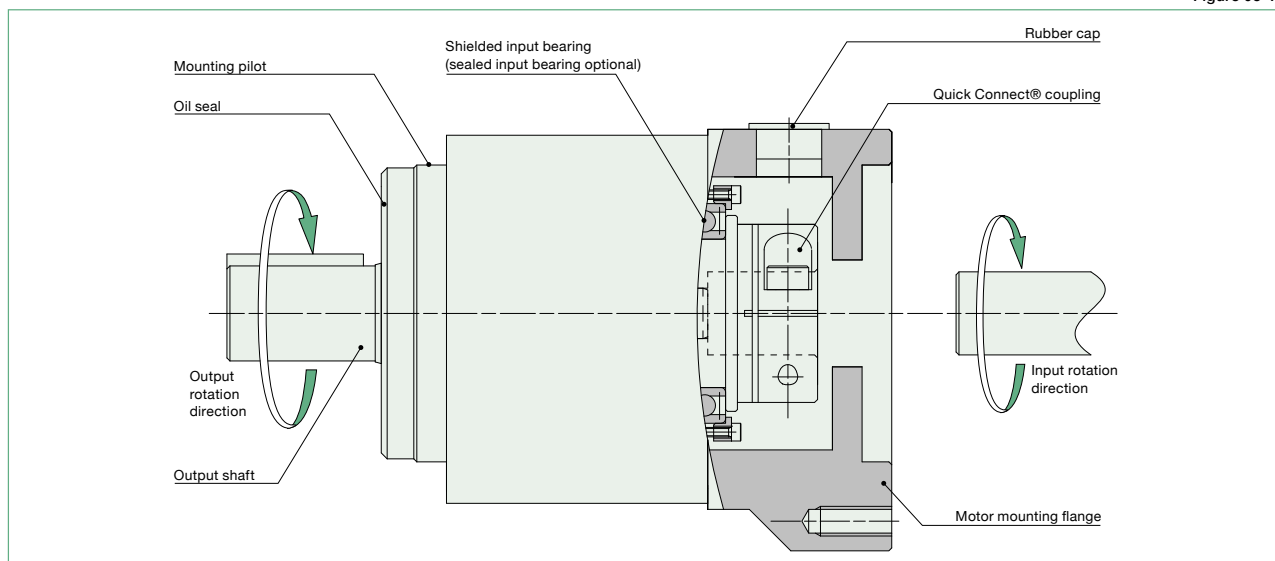

HarmonicPlanetary[®] HPN Face-Mount Series

HPN Precision Planetary Gearheads are Quiet, Lightweight and Compact with Low Cost and Quick Delivery.

HPN Planetary gearheads feature a robust design utilizing helical gears for quiet performance and long life. These gearheads are available with short lead times and are designed to couple to any servomotor with our Quick Connect[®] coupling. HPN gearheads are suitable for use in a wide range of applications for precision motion control and positioning. HPN Harmonic Planetary[®] gears are available in 3 sizes: 14, 20, and 32 with reduction ratios ranging from 3:1 to 50:1.

- ◆ **Backlash: Single Stage <5 arc-min, Two Stage <7 arc-min**
- ◆ **Gear Ratios: Single Stage: 3:1 to 10:1, Two Stage: 15:1 to 50:1**
- ◆ **High Efficiency**
- ◆ **Helical Gearing**
- ◆ **Quiet Design: Noise <56dB**



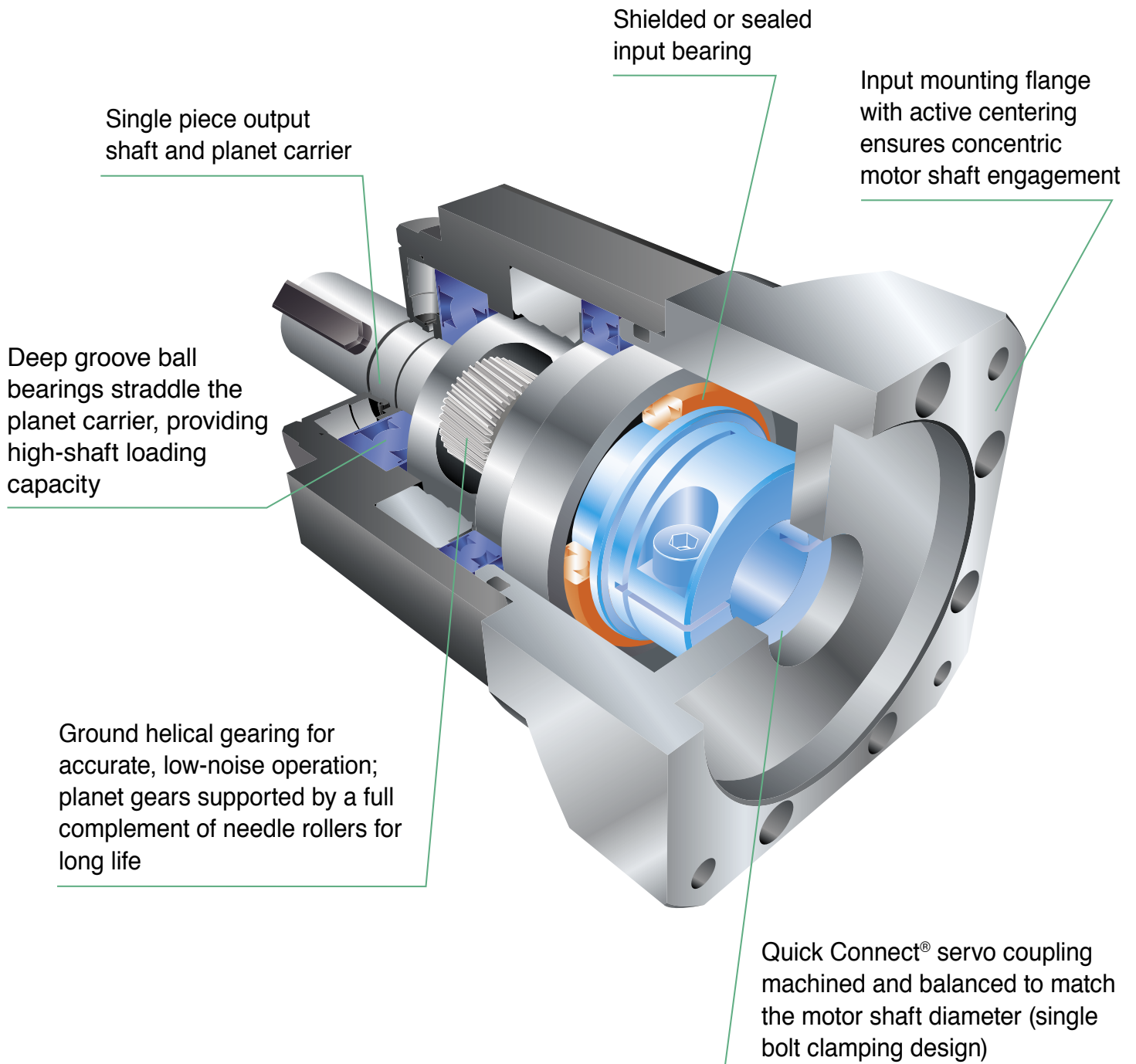

Application Examples for Harmonic Planetary® Gearheads

The Harmonic Planetary® gearheads are especially suitable for a wide range of high technology fields requiring precision motion control.

Linear axis for robots (Racks and pinion)

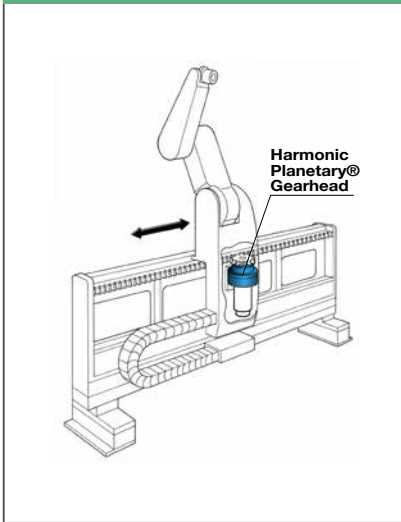

Gantry robots

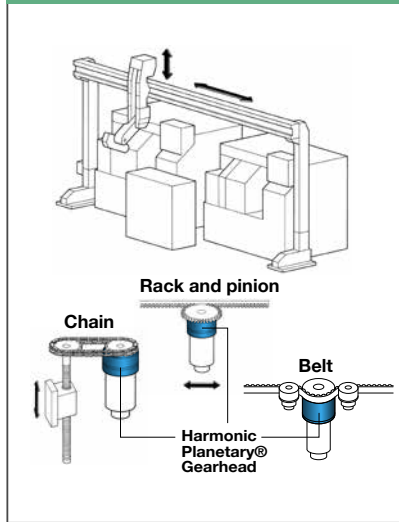

Linear axis drive

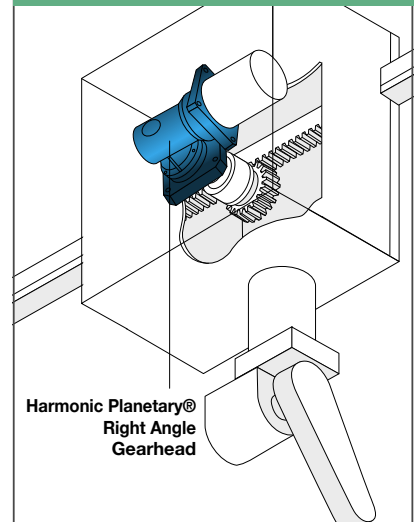

Wafer transfer robots

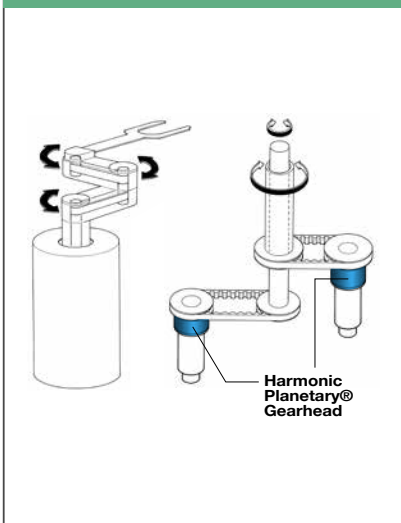

Electric presses

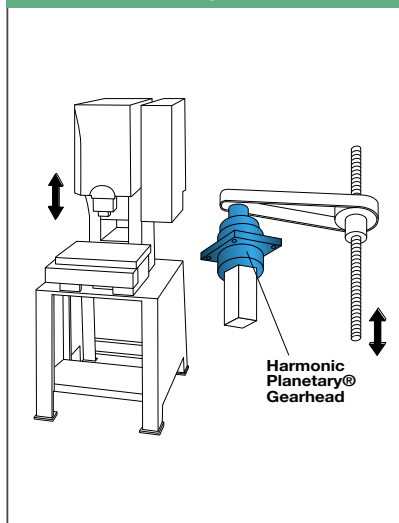

Pipe benders

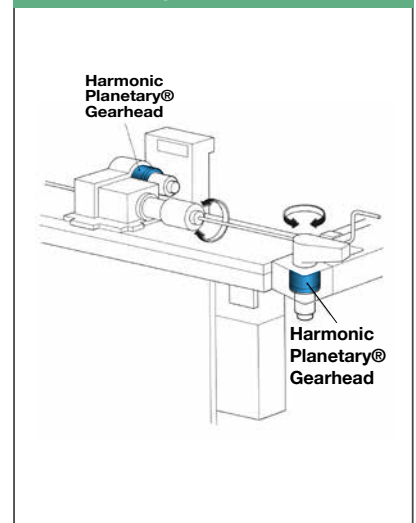

Injection molding unloading robots

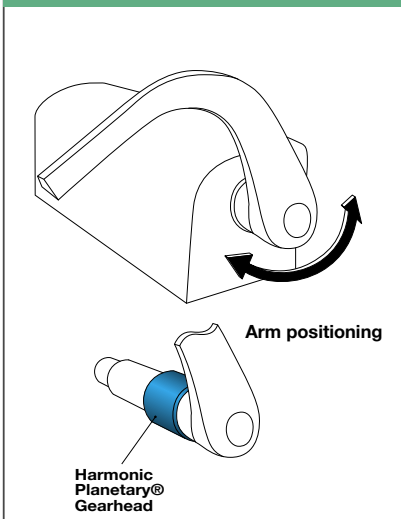

Tensile strength testers

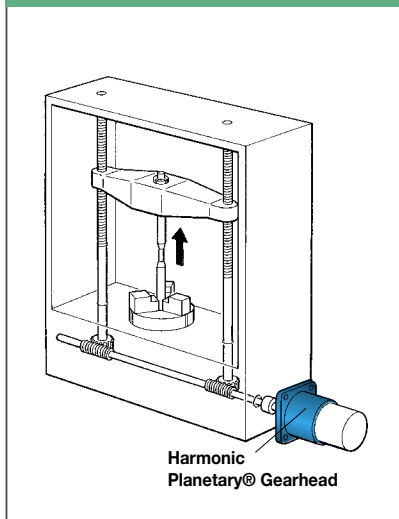

X-Y axes of machine tools

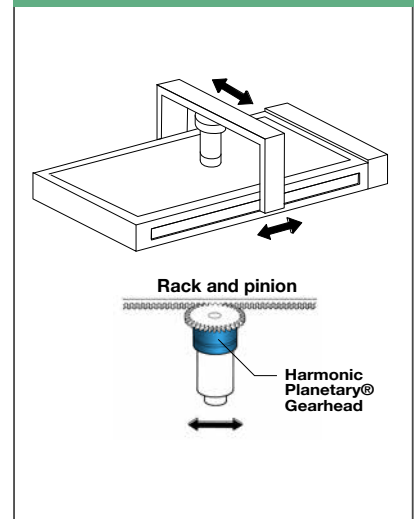

HPN-L Series
High-Performance Gearhead for Servomotors

Rating Table

Table 09-1

Size	Number of Stages	Ratio	Rated Torque L10 *1	Rated Torque L50 *1	Limit for Repeated Peak Torque *2	Limit for Momentary Torque *3	Max. Average Input Speed*4	Max. Input Speed*6	Allowable Radial Load*6	Allowable Axial Load*7
			Nm	Nm	Nm	Nm	rpm	rpm	N	N
14	1	3	14	22	25	89	3,000	10,000	840	900
		4	18	28	50	110				
		5	18	29	50	107				
		7	20	30	37	100				
		10	14	18	18	79				
	2	15	21	30	43	97				
		20	23	30	49	100				
		25	26	30	38	102				
		30	26	40	48	98				
		35	28	40	49	99				
		40	29	30	38	100				
		45	29	30	38	100				
		50	20	26	26	94				
		20	1	3	31	51				
4	50			80	130	256				
5	52			80	149	256				
7	55			80	113	256				
10	41			54	54	216				
2	15		59	80	129	256				
	20		66	80	147	256				
	25		72	80	114	256				
	30		72	80	139	250				
	35		79	80	112	256				
	40		81	80	112	256				
	45		84	80	112	256				
	50		58	75	75	216				
	32		1	3	94	153	254	625	3,000	6,000
4		122		198	376	625				
5		127		200	376	625				
7		135		200	376	625				
10		128		185	185	625				
2		15	146	200	376	625				
		20	162	200	376	625				
		25	176	200	376	625				
		30	179	250	376	625				
		35	193	250	376	625				
		40	200	300	376	625				
		45	206	300	376	625				
		50	193	251	251	625				

*1: Rated torque is based on life of 20,000 hours at max average input speed.

*2: The limit for torque during start and stop cycles.

*3: The limit for torque during emergency stops or from external shock loads. Always operate below this value.

*4: Max value of average input rotational speed during operation.

*5: Maximum instantaneous input speed.

*6. The load at which the output bearing will have 20,000 hour life at 100 rpm output speed (Axial load = 0 and radial load point is in the center of the output shaft)

*7. The load at which the output bearing will have 20,000 hour life at 100 rpm output speed (Radial load = 0 and axial load point is in the center of the output shaft)

Performance

Table 010-1

Size	Number of Stages	Ratio	Backlash	Noise*1	Torsional Stiffness	
			arc min	dB	kgfm/arc-min	X100N·m/rad
14	1	3	< 5	< 58	0.27	93
		4				
		5				
		7				
		10				
	2	15	< 7			
		20				
		25				
		30				
		35				
		40				
		45				
		50				
		50				
20	1	3	< 5	< 60	0.77	260
		4				
		5				
		7				
		10				
	2	15	< 7			
		20				
		25				
		30				
		35				
		40				
		45				
		50				
		50				
32	1	3	< 5	< 63	2.8	940
		4				
		5				
		7				
		10				
	2	15	< 7			
		20				
		25				
		30				
		35				
		40				
		45				
		50				
		50				

*1: The above noise values are reference values.

HPN-L Series HarmonicPlanetary®
 High-Performance Gearhead for Servomotors

HPN-14L Outline Dimensions

Figure 011-1

(Unit: mm)

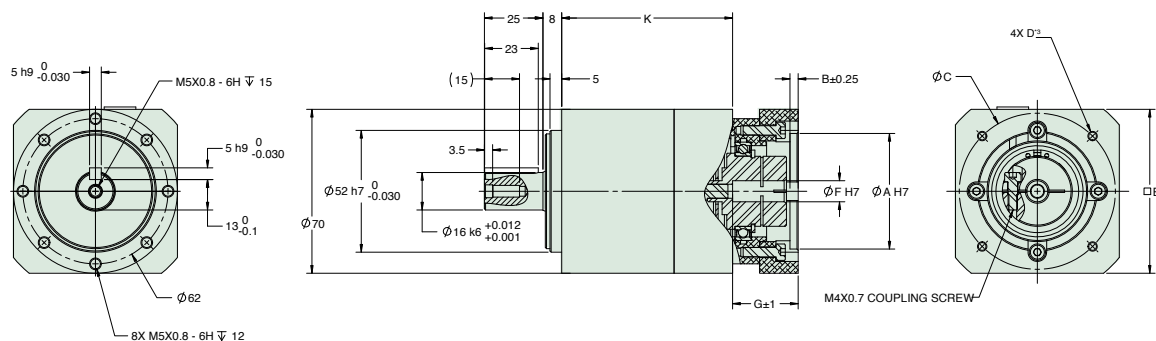

(Note) The dimension tolerances that are not specified vary depending on the manufacturing method. Please check the confirmation drawing or contact us for dimension tolerances not shown on the drawing above. Output shaft configuration shown is J6 (with a key and center tapped hole). J8 configuration has no key.

Dimension Table

(Unit: mm) Table 011-1

	Flange	Coupling	A (H7) ^{*1}		B ^{*1}	C ^{*1}		F (H7) ^{*1}		G ^{*1}		H ^{*1}	K	Mass(kg) ^{*2}
			Min.	Max.	Max.	Min.	Max.	Min.	Max.	Min.	Max.			
Single Stage	3	3	35	75	5	40	100	6	14	18	28	>109	48	0.95
Two Stage			>134	73	1.3									

Refer to the confirmation drawing for detailed dimensions. Dimensions of typical products are shown. Please contact us for other mounting options if the configurations shown above are not suitable for your particular motor.

*1 May vary depending on motor interface dimensions.

*2 The mass will vary slightly depending on the ratio and on the inside diameter of the input shaft coupling.

*3 Tapped hole for motor mounting screw.

Moment of Inertia

(10⁻⁴ kgm²) Table 011-2

HPN-14L	Ratio	3	4	5	7	10	15	20	25	30	35	40	45	50
	Coupling	0.26	0.23	0.21	0.20	0.20	0.20	0.20	0.20	0.19	0.19	0.19	0.19	0.19
	3	0.26	0.23	0.21	0.20	0.20	0.20	0.20	0.20	0.19	0.19	0.19	0.19	0.19

HPN-20L Outline Dimensions

Figure 012-1
(Unit: mm)

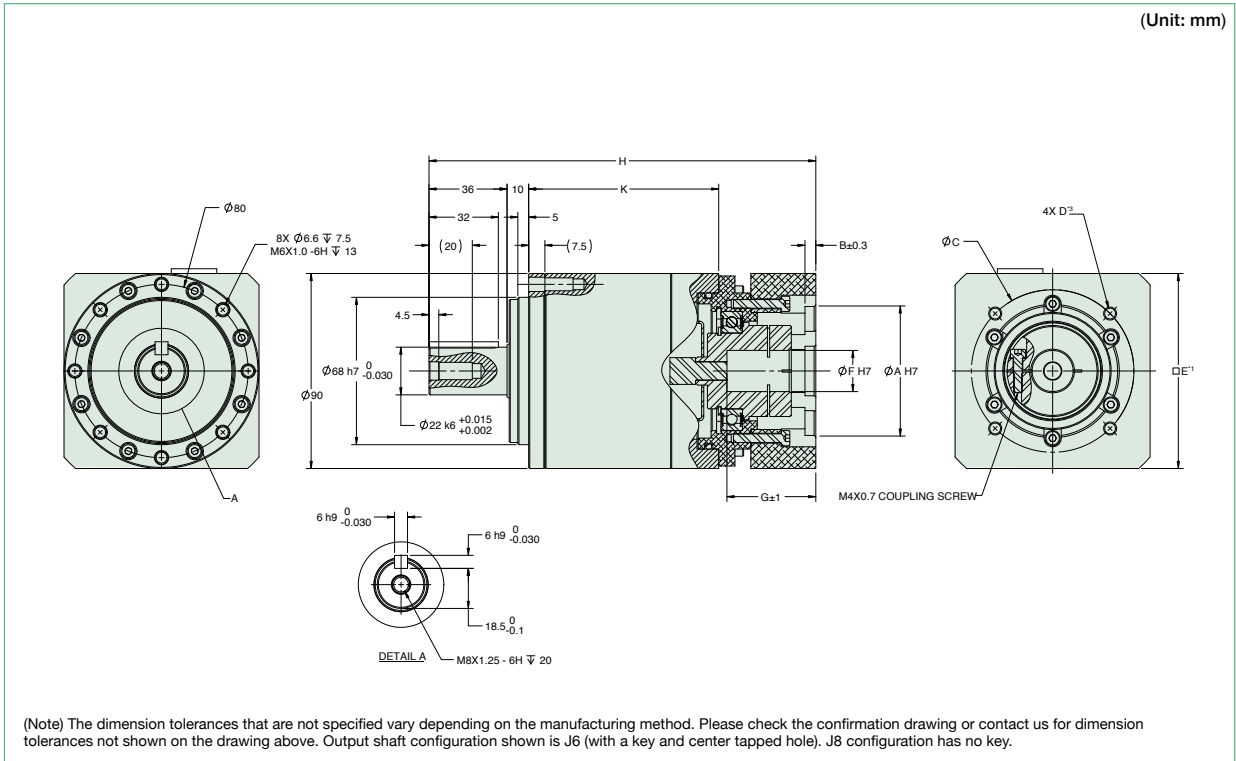

Dimension Table

(Unit: mm) Table 012-1

	Flange	Coupling	A (H7) ^{*1}		B ^{*1}	C ^{*1}		F (H7) ^{*1}		G ^{*1}		H ^{*1}	K	Mass(kg) ^{*2}
			Min.	Max.	Max.	Min.	Max.	Min.	Max.	Min.	Max.			
Single Stage	1	1	50	85	7	55	115	13.5	25.4	26	47	156.8	66	3
Two Stage										24.5	41			
Single Stage	2	1	50	125	7	60	155	13.5	25.4	44	65	174.8	66	3.7
Two Stage										42.5	59			
Single Stage	3	2	35	75	7	40	100	9.5	14.2	25.5	40.5	150.9	66	2.6
Two Stage										4	3			

Refer to the confirmation drawing for detailed dimensions. Dimensions of typical products are shown. Please contact us for other mounting options if the configurations shown above are not suitable for your particular motor.

*1 May vary depending on motor interface dimensions.

*2 The mass will vary slightly depending on the ratio and on the inside diameter of the input shaft coupling.

*3 Tapped hole for motor mounting screw.

Moment of Inertia

(10⁻⁴ kgm²) Table 012-2

HPN-20L	Ratio	3	4	5	7	10	15	20	25	30	35	40	45	50
	Coupling	1.20	1.00	0.92	0.87	0.86	0.86	0.87	0.87	0.85	0.86	0.85	0.85	0.85
1	1.20	1.00	0.92	0.87	0.86	0.86	0.87	0.87	0.85	0.86	0.85	0.85	0.85	0.85
2	0.53	0.36	0.29	0.24	0.21	-	-	-	-	-	-	-	-	-
3	-	-	-	-	-	0.23	0.22	0.22	0.20	0.21	0.20	0.20	0.20	0.20

HPN-32L Outline Dimensions

Figure 013-1
(Unit: mm)

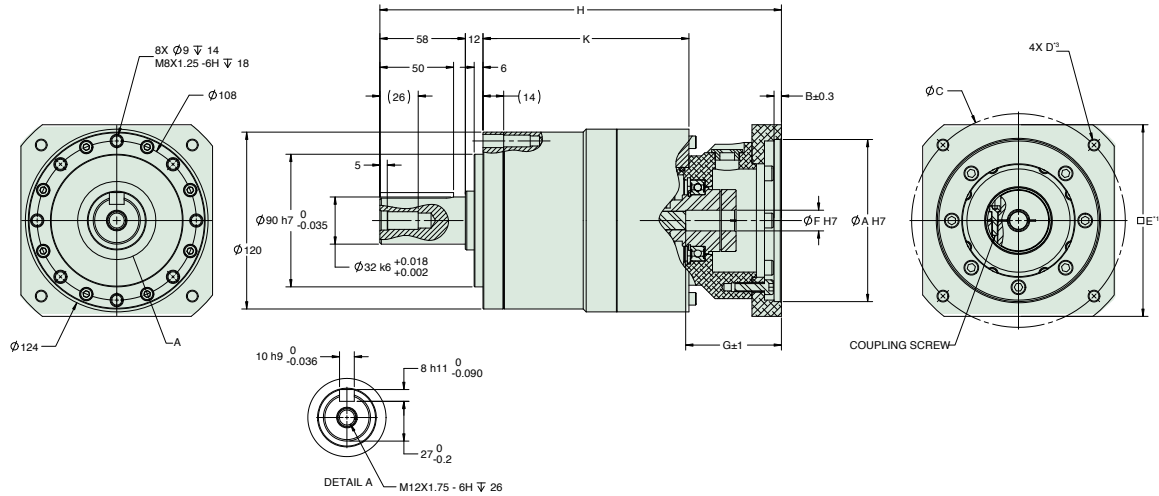

(Note) The dimension tolerances that are not specified vary depending on the manufacturing method. Please check the confirmation drawing or contact us for dimension tolerances not shown on the drawing above. Output shaft configuration shown is J6 (with a key and center tapped hole). J8 configuration has no key.

Dimension Table

(Unit: mm) Table 013-1

	Flange	Coupling	A (H7) ^{*1}		B ^{*1}	C ^{*1}		F (H7) ^{*1}		G ^{*1}		H ^{*1}	K	Mass(kg) ^{*2}
			Min.	Max.	Max.	Min.	Max.	Min.	Max.	Min.	Max.			
Single Stage	1	1	50	85	7	55	115	13.5	25.4	25	51	212.5	91	6.6
	2	2	55	125	7	65	155	15.5	28	42	64	230	91	7.7
	3	3	65	215	6.5	75	260	21.5	41	47	85	251	91	9.3
Two Stage	4	4	50	85	7	55	115	13.5	25.4	26	46.5	254.5	139.7	7.9
	5	4	50	125	7	60	155	13.5	25.4	44	65	272.5	139.7	9.1
	6	5	35	75	7	40	100	9.5	14.2	25.5	40.5	248.6	139.7	7.2

Refer to the confirmation drawing for detailed dimensions. Dimensions of typical products are shown. Please contact us for other mounting options if the configurations shown above are not suitable for your particular motor.

*1 May vary depending on motor interface dimensions.

*2 The mass will vary slightly depending on the ratio and on the inside diameter of the input shaft coupling.

*3 Tapped hole for motor mounting screw.

Moment of Inertia

(10⁻⁴ kgm²) Table 013-2

HPN-32L	Ratio	3	4	5	7	10	15	20	25	30	35	40	45	50
	Coupling	3	4	5	7	10	15	20	25	30	35	40	45	50
	1	2.3	1.7	1.5	1.3	1.2	-	-	-	-	-	-	-	-
	2	4.9	3.6	3.1	2.7	2.5	-	-	-	-	-	-	-	-
	3	6.9	5.7	5.2	4.8	4.7	-	-	-	-	-	-	-	-
	4	-	-	-	-	-	1.1	1.0	1.0	0.91	0.93	0.91	0.89	0.91
	5	-	-	-	-	-	0.48	0.40	0.42	0.28	0.30	0.28	0.25	0.25

Sizing & Selection

To fully utilize the excellent performance of the HPN HarmonicPlanetary® gearheads, check your operating conditions and, using the flowchart, select the appropriate size gear for your application.

Check your operating conditions against the following application motion profile and select a suitable size based on the flowchart shown on the right. Also, compare any application radial and axial loads supported by the gearhead output shaft to the allowable values in the ratings table to ensure an adequate output bearing service life.

Application motion profile

Review the application motion profile. Check the specifications shown in the figure below.

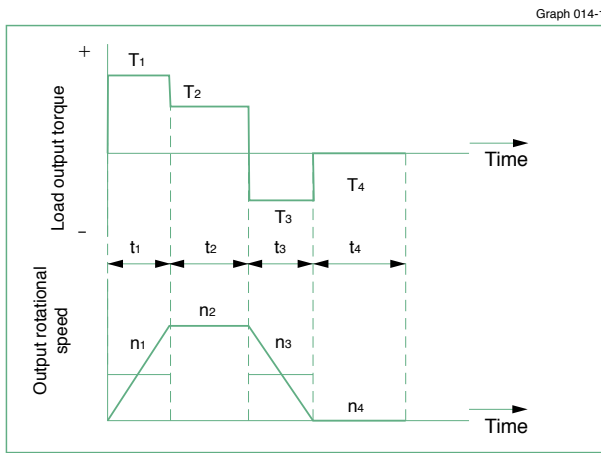

Obtain the value of each application motion profile	
Load torque	T ₁ to T _n (Nm)
Time	t ₁ to t _n (sec)
Output rotational speed	n ₁ to n _n (rpm)
Normal operation pattern	
Starting (Acceleration)	T ₁ , t ₁ , n ₁
Steady operation (constant velocity)	T ₂ , t ₂ , n ₂
Stopping (deceleration)	T ₃ , t ₃ , n ₃
Dwell	T ₄ , t ₄ , n ₄
Maximum rotational speed	
Max. output rotational speed	n _{0 max} ≥ n ₁ to n _n
Max. input rotational speed (Restricted by motors)	n _{i max} n ₁ × R to n _n × R
	R: Reduction ratio
Emergency stop torque	
When impact torque is applied	T _s
Required life	L ₁₀ = L (hours)

Flowchart for selecting a size

Please use the flowchart shown below for selecting a size. Operating conditions must not exceed the performance ratings.

Calculate the average load torque applied on the output side from the application motion profile: T_{av} (Nm).

$$T_{av} = \frac{10/3 \sqrt{|n_1 \cdot t_1 \cdot |T_1|^{10/3} + |n_2 \cdot t_2 \cdot |T_2|^{10/3} + \dots + |n_n \cdot t_n \cdot |T_n|^{10/3}}}{n_1 \cdot t_1 + n_2 \cdot t_2 + \dots + n_n \cdot t_n}$$

Calculate the average output speed based on the application motion profile: n_{o av} (rpm)

$$n_{o av} = \frac{|n_1 \cdot t_1 + n_2 \cdot t_2 + \dots + n_n \cdot t_n|}{t_1 + t_2 + \dots + t_n}$$

Make a preliminary model selection with the following condition: T_{av} ≤ Average load torque (Refer to rating table).

Determine the reduction ratio (R) based on the maximum output rotational speed (n_{o max}) and maximum input rotational speed (n_{i max}).

$$\frac{n_{i max}}{n_{o max}} \geq R$$

(A limit is placed on n_{i max} by motors.)
Calculate the maximum input speed (n_{i max}) from the maximum output speed (n_{o max}) and the reduction ratio (R).
n_{i max} = n_{o max} · R

Calculate the average input speed (n_{i av}) from the average output speed (n_{o av}) and the reduction ratio (R): n_{i av} = n_{o av} · R ≤ Max. average input speed (n_r).

Check whether the maximum input speed is equal to or less than the values in the rating table.
n_{i max} ≤ maximum input speed (rpm)

Check whether T₁ and T₃ are within Limit for Repeated Peak Torque (Nm) on start and stop in the rating table.

Check whether T_s is less than the Limit for Momentary Peak Torque (Nm) value from the ratings.

Calculate the life and check whether it meets the specification requirement.
T_r: Rated torque
n_r: Max. average input speed

$$L_{10} = 20,000 \cdot \left(\frac{T_r}{T_{av}} \right)^{10/3} \cdot \left(\frac{n_r}{n_{i av}} \right) \text{ (Hour)}$$

The model number is confirmed.

Refer to the Caution note below.

Review the operation conditions, size and reduction ratio.

Caution

If any of the following conditions exist, please consider selecting the next larger speed reducer, reduce the operating loads or reduce the operating speed. If this cannot be done, please contact Harmonic Drive LLC. Exercise caution especially when the duty cycle is close to continuous operation.

- i) Actual average load torque (T_{av}) > Rated Torque or
- ii) Actual average input rotational speed (n_{i av}) > max. average input speed (n_r),
- iii) Gearhead housing temperature > 70°C.

Example of size selection

Load torque	T_n (Nm)	Maximum rotational speed Max. output rotational speed Max. input rotational speed	no max = 120 rpm ni max = 5,000 rpm (Restricted by motors)
Time	t_n (sec)		
Output rotational speed	n_n (rpm)		
Normal operation pattern		Emergency stop torque When impact torque is applied	$T_s = 180$ Nm
Starting (acceleration)	$T_1 = 70$ Nm, $t_1 = 0.3$ sec, $n_1 = 60$ rpm		
Steady operation (constant velocity)	$T_2 = 18$ Nm, $t_2 = 3$ sec, $n_2 = 120$ rpm		
Stopping (deceleration)	$T_3 = 35$ Nm, $t_3 = 0.4$ sec, $n_3 = 60$ rpm		
Dwell	$T_4 = 0$ Nm, $t_4 = 5$ sec, $n_4 = 0$ rpm		
		Required life $L_{50} = 30,000$ (hours)	

Calculate the average load torque applied to the output side based on the load torque pattern: T_{av} (Nm).

$$T_{av} = \sqrt[10/3]{\frac{160\text{rpm} \cdot 1 \cdot 0.3\text{sec} \cdot 170\text{Nm}^{10/3} + 1120\text{rpm} \cdot 13\text{sec} \cdot 118\text{Nm}^{10/3} + 160\text{rpm} \cdot 10.4\text{sec} \cdot 135\text{Nm}^{10/3}}{160\text{rpm} \cdot 0.3\text{sec} + 120\text{rpm} \cdot 3\text{sec} + 160\text{rpm} \cdot 0.4\text{sec}}}$$

Calculate the average output speed based on the load torque pattern: no av (rpm)

$$\text{no av} = \frac{160\text{rpm} \cdot 0.3\text{sec} + 1120\text{rpm} \cdot 3\text{sec} + 160\text{rpm} \cdot 0.4\text{sec} + 10\text{rpm} \cdot 5\text{sec}}{0.3\text{sec} + 3\text{sec} + 0.4\text{sec} + 5\text{sec}}$$

Make a preliminary model selection with the following conditions. $T_{av} = 30.2$ Nm \approx 80 Nm. (HPN-20L-30 is tentatively selected based on the average load torque (see the rating table) of size 20 and reduction ratio of 30.)

OK

Determine a reduction ratio (R) from the maximum output speed (no max) and maximum input speed (ni max).

$$\frac{5,000 \text{ rpm}}{120 \text{ rpm}} = 41.7 \approx 30$$

Calculate the maximum input speed (ni max) from the maximum output speed (no max) and reduction ratio (R): ni max = 120 rpm \cdot 30 = 3,720 rpm

OK

Calculate the average input speed (ni av) from the average output speed (no av) and reduction ratio (R):

$$\text{ni av} = 46.2 \text{ rpm} \cdot 30 = 1,386 \text{ rpm} \approx \text{Max average input speed of size 20 } 3,000 \text{ rpm}$$

OK

Check whether the maximum input speed is less than the values specified in the rating table.
ni max = 3,720 rpm \leq 6,000 rpm (maximum input speed of size 20)

OK

Check whether T_1 and T_3 are within limit for repeated peak torque (Nm) on start and stop in the rating table.

$$T_1 = 70 \text{ Nm} \leq 139 \text{ Nm (Limit for repeated peak torque, size 20)}$$

$$T_3 = 35 \text{ Nm} \leq 139 \text{ Nm (Limit for repeated peak torque, size 20)}$$

OK

Check whether T_s is less than limit for momentary torque (Nm) in the rating table.

$$T_s = 180 \text{ Nm} \leq 250 \text{ Nm (momentary max. torque of size 20)}$$

OK

Calculate life and check whether the calculated life meets the requirement.

$$L_{50} = 20,000 \cdot \left(\frac{80\text{Nm}}{30.2\text{Nm}}\right)^{10/3} \cdot \left(\frac{3,000\text{rpm}}{1,432\text{rpm}}\right) = 25,809,937 \text{ (hours)} \approx 30,000 \text{ (hours)}$$

OK

The selection of model number HPN-20L-30 is confirmed from the above calculations.

Refer to the Caution note at the bottom of page 14.

Review the operation conditions, size and reduction ratio.



Harmonic Planetary®

Technical Information

Efficiency	17
Output Shaft Bearing Load Limits	20

Product Handling

Assembly	21
Lubrication	22
Warranty, Disposal	23
Safety	24

Efficiency

In general, the efficiency of a speed reducer depends on the reduction ratio, input rotational speed, load torque, temperature and lubrication condition. The efficiency of each series under the following measurement conditions is plotted in the graphs on the next page. The values in the graph are average values.

Measurement condition

Table 017-1

Input rotational speed	HPN:3000rpm
Ambient temperature	25°C
Lubricant	Use standard lubricant for each model. (See page 23 for details.)

Efficiency compensated for low temperature

Calculate the efficiency at an ambient temperature of 25°C or less by multiplying the efficiency at 25°C by the low-temperature efficiency correction value. Obtain values corresponding to an ambient temperature and to an input torque (TRi*) from the following graphs when calculating the low-temperature efficiency correction value.

HPN

* TRi is an input torque corresponding to output torque at 25°C.

Graph 017-1

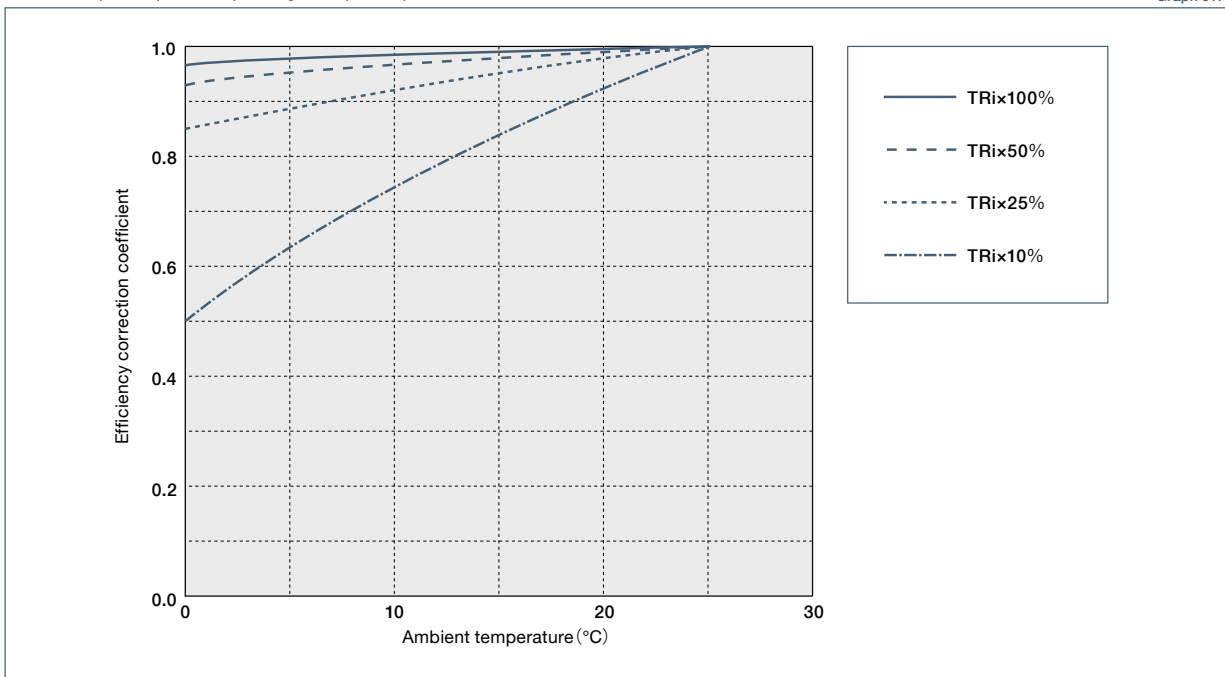

Size 14

HPN

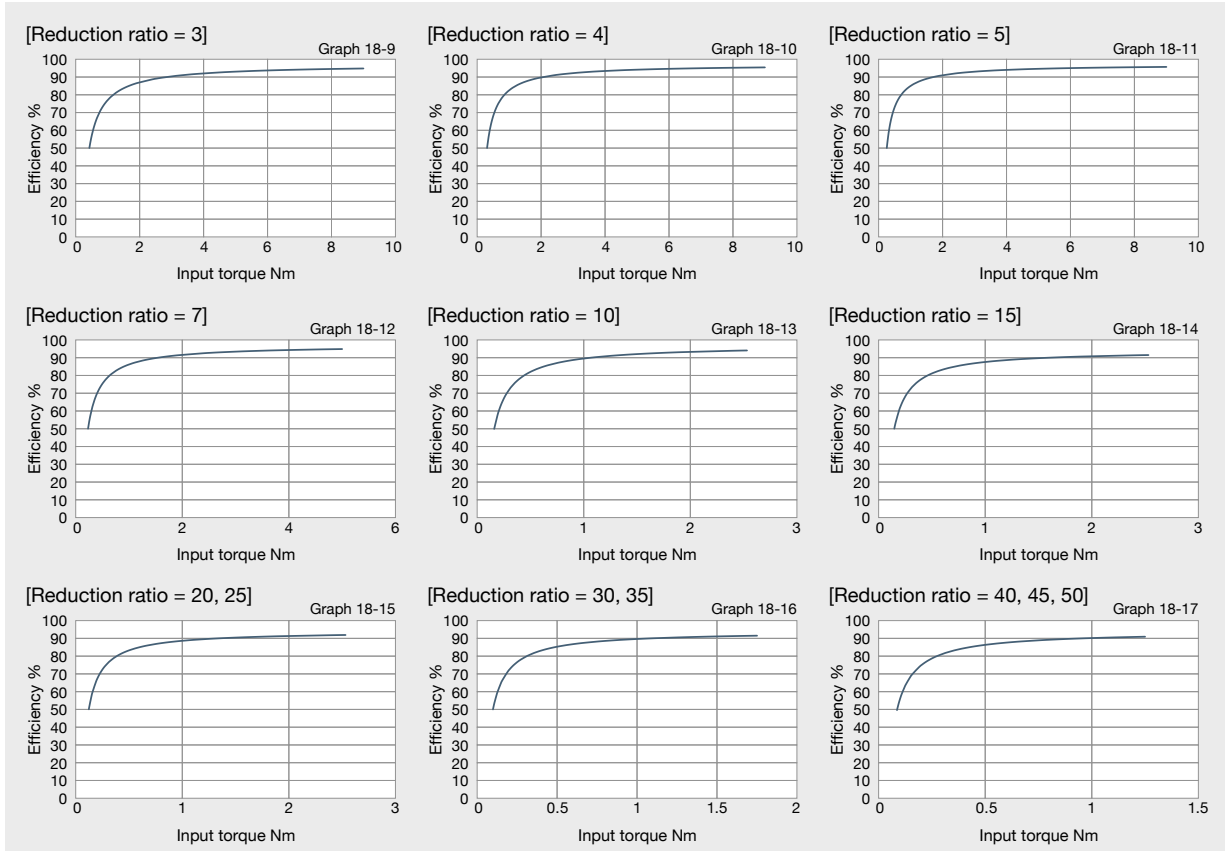

Size 20

HPN

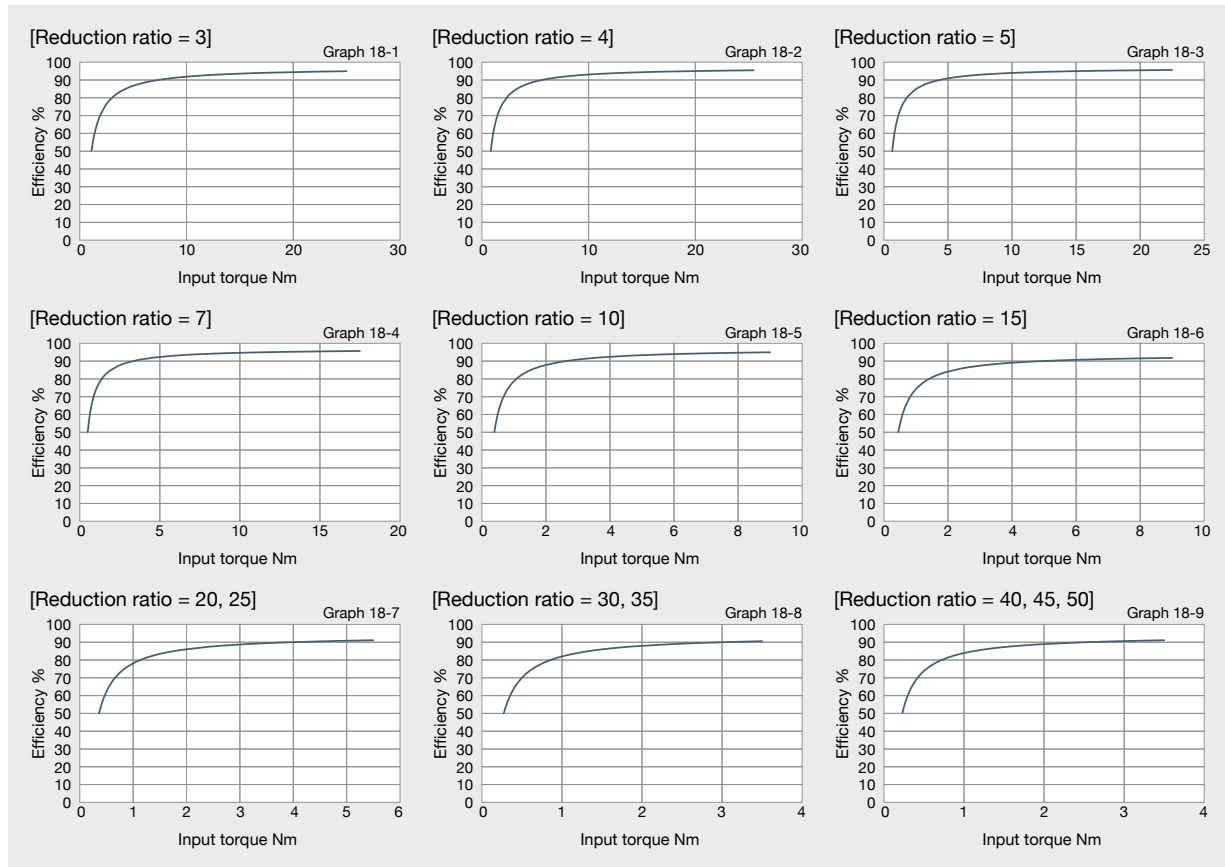

Size 32

HPN

[Reduction ratio = 3]

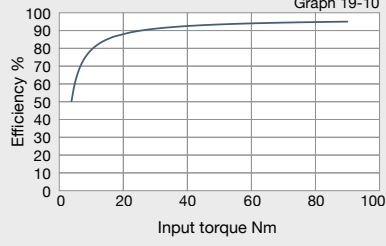

[Reduction ratio = 4]

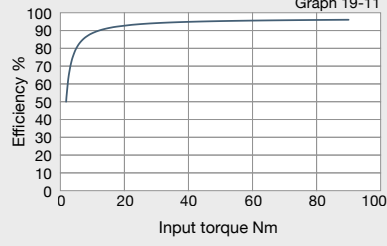

[Reduction ratio = 5]

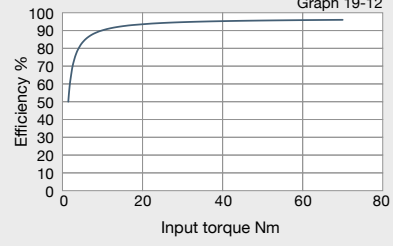

[Reduction ratio = 7]

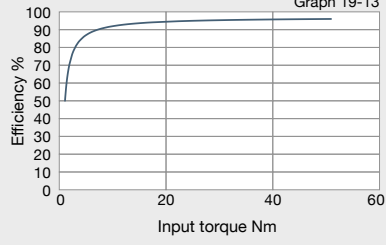

[Reduction ratio = 10]

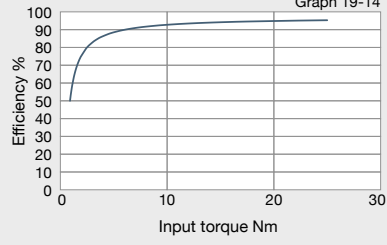

[Reduction ratio = 15]

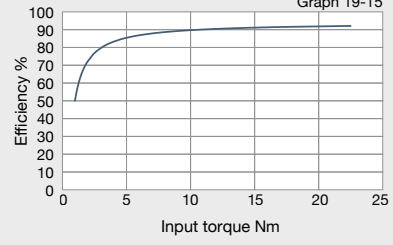

[Reduction ratio = 20, 25]

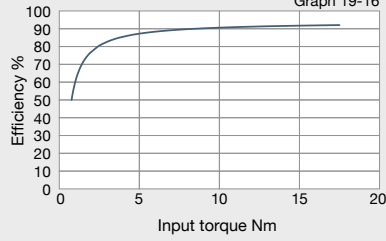

[Reduction ratio = 30, 35]

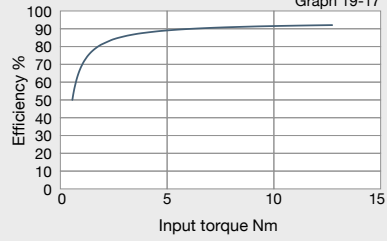

[Reduction ratio = 40, 45, 50]

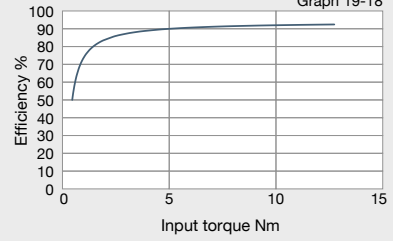

Output Shaft Bearing Load Limits

HPN Series Output Shaft Load Limits are plotted below.

HPN uses deep groove radial ball bearings to support the output shaft. Please use the curve on the graph for the appropriate load coefficient (fw) that represents the expected operating condition.

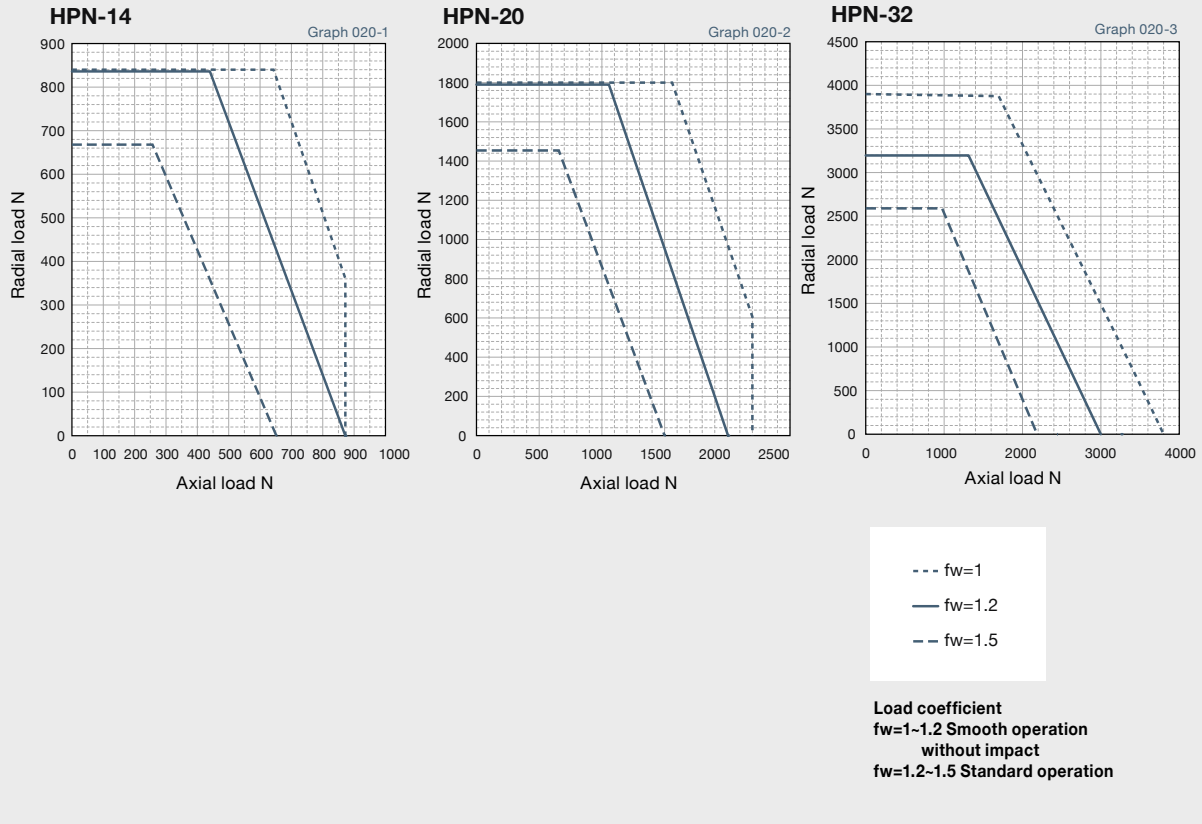

Output shaft speed - 100 rpm, bearing life is based on 20,000 hours. The load-point is based on shaft center of radial load and axial load.

Assembly

Assemble and mount your gearhead in accordance with these instructions to achieve the best performance. Be sure to use the recommended bolts and use a torque wrench to achieve the proper tightening torques as recommended in the tables below.

Motor assembly procedure HPN

To properly mount the motor to the gearhead, follow the procedure outlined below, refer to figure 025-1

- (1) Turn the input shaft coupling and align the bolt head with the rubber cap hole.
- ↓
- (2) With the speed reducer in an upright position as illustrated in the figure below, slowly insert the motor shaft into the coupling of speed reducer. Slide the motor shaft without letting it drop down. If the speed reducer cannot be positioned upright, slowly insert the motor shaft into the coupling of speed reducer, then tighten the motor bolts evenly until the motor flange and gearhead flange are in full contact. Exercise care to avoid tilting the motor when inserting it into the gear head.

- (3) Tighten the input shaft coupling bolt to the recommended torque specified in the table below. The bolt(s) or screw(s) is (are) already inserted into the input coupling when delivered. Check the bolt size on the confirmation drawing provided.

Bolt tightening torque

Table 021-1

Bolt size		M3	M4	M5	M6	M8	M10	M12
Tightening torque	Nm	2.0	4.5	9.0	15.3	37.2	73.5	128
	kgfm	0.20	0.46	0.92	1.56	3.8	7.5	13.1

Caution: Always tighten the bolts to the tightening torque specified in the table above. If the bolt is not tightened to the torque value recommended slippage of the motor shaft in the shaft coupling may occur. The bolt size will vary depending on the size of the gear and the shaft diameter of the mounted motor. Check the bolt size on the confirmation drawing provided.

- (4) Fasten the motor to the gearhead flange with bolts.

Bolt* tightening torque

Table 021-2

Bolt size		M2.5	M3	M4	M5	M6	M8	M10	M12
Tightening torque	Nm	0.59	1.4	3.2	6.3	10.7	26.1	51.5	89.9
	kgfm	0.06	0.14	0.32	0.64	1.09	2.66	5.25	9.17

* Recommended bolt: JIS B 1176 Hexagon socket head bolt, Strength: JIS B 1051 12.9 or higher

Caution: Be sure to tighten the bolts to the tightening torques specified in the table.

- (5) Insert the rubber cap provided. This completes the assembly.

Figure 021-1

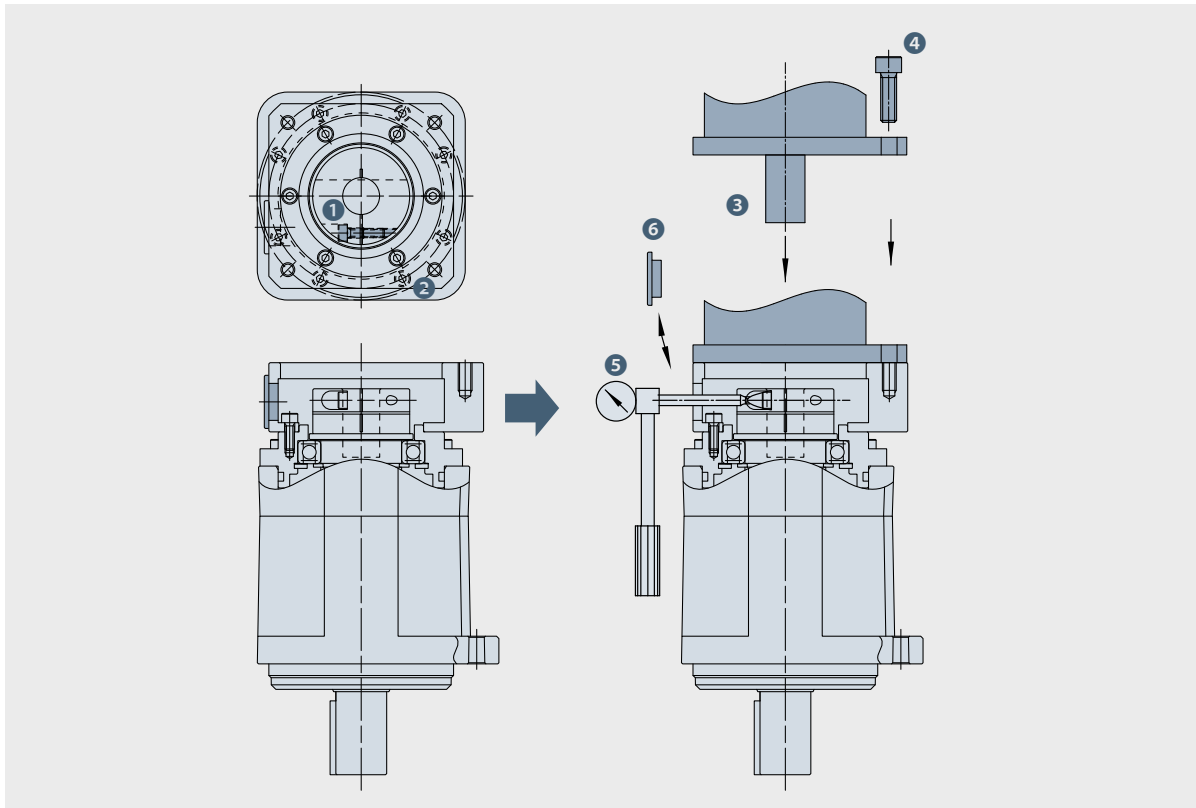

Lubrication

Prevention of grease and oil leakage

- Only use the recommended greases.
- Provisions for proper sealing to prevent grease leakage are incorporated into the gearheads. However, please note that some leakage may occur depending on the application or operating condition. Discuss other sealing options with our applications engineers.
- When mounting the gearhead horizontally, position the gearhead so that the rubber cap in the adapter flange is facing upwards.

Sealing

- Provisions for proper sealing to prevent grease leakage from the input shaft are incorporated into the gearhead.
- A double lip Teflon oil seal is used for the output shaft, gaskets or o-rings are used on all mating surfaces, and non contact shielded bearings are used for the motor shaft coupling (Double sealed bearings (D type) are available as an option*) .
- Material and surface: Gearbox: Aluminum, carbon steel (output shaft).
Adapter flange: (if provided by Harmonic Drive) high-strength aluminum or carbon steel. Screws: black phosphate. The ambient environment should not subject any corrosive agents to the above mentioned material. The product provides protection class IP 54 under the provision that corrosion from the ambient atmosphere (condensation, liquids or gases) at the running surface of the output shaft seal is prevented. If necessary, the adapter flange can be sealed by means of a surface seal (e.g. Loctite 515).

* D type: Bearing with a rubber contact seal on both sides

Standard Lubricants

HPN Series

The standard lubrication for the HPN series gearheads is grease.

All gearheads are lubricated at the factory prior to shipment and additional application of grease during assembly is not required.

The gearheads are lubricated for the life of the gear and do not require re-lubrication.

High efficiency is achieved through the unique planetary gear design and grease selection.

Ambient operating temperature range: -10°C to +40°C

The lubricant may deteriorate if the ambient operating temperature is outside of recommended operating range. Please contact our sales office or distributor for operation outside of the ambient operating temperature range.

The temperature rise of the gear depends upon the operating cycle, ambient temperature and heat conduction and radiation based on the customers installation of the gear. A housing surface temperature of 70°C is the maximum allowable limit.

Warranty

Please contact us or visit our website at www.harmonicdrive.net for warranty details for your specific product.

All efforts have been made to ensure that the information in this catalog is complete and accurate. However, Harmonic Drive LLC is not liable for any errors, omissions or inaccuracies in the reported data. Harmonic Drive LLC reserves the right to change the product specifications, for any reason, without prior notice. For complete details please refer to our current Terms and Conditions posted on our website.

Disposal



When disposing of the product, disassemble it and sort the component parts by material type and dispose of the parts as industrial waste in accordance with the applicable laws and regulations. The component part materials can be classified into three categories.

- (1) Rubber parts: Oil seals, seal packings, rubber caps, seals of shielded bearings on input side (D type only)
- (2) Aluminum parts: Housings, motor flanges
- (3) Steel parts: Other parts

Trademark

HarmonicDrive® is a registered trademark of Harmonic Drive LLC.
HarmonicPlanetary® is a registered trademark of Harmonic Drive LLC.

Safety

-  **Warning** : Means that improper use or handling could result in a risk of death or serious injury.
-  **Caution** : Means that improper use or handling could result in personal injury or damage to property.





Application Restrictions







This product cannot be used for the following applications:





- * Space flight hardware
- * Aircraft equipment
- * Nuclear power equipment
- * Equipment and apparatus used in residential dwellings
- * Vacuum environments
- * Automotive equipment
- * Personal recreation equipment
- * Equipment that directly works on human bodies
- * Equipment for transport of humans
- * Equipment for use in a special environment
- * Medical equipment

Please consult Harmonic Drive LLC beforehand if intending to use one of our product for the aforementioned applications.

Fail-safe devices that prevent an accident must be designed into the equipment when the products are used in any application that could result in personal injury or damage to property in the event of product failure.

Design Precaution: Be certain to read the catalog when designing the equipment.	
 Caution	<p>Use only in the proper environment.</p> <ul style="list-style-type: none"> ● Please ensure to comply with the following environmental conditions: <ul style="list-style-type: none"> • Ambient temperature 0 to 40°C • No splashing of water or oil • Do not expose to corrosive or explosive gas • No dust such as metal powder
 Caution	<p>Install the equipment properly.</p> <ul style="list-style-type: none"> ● Carry out the assembly and installation precisely as specified in the catalog. ● Observe our recommended fastening methods (including bolts used and tightening torques). ● Operating the equipment without precise assembly can cause problems such as vibration, reduction in life, deterioration of precision and product failure.
 Caution	<p>Install the equipment with the required precision.</p> <ul style="list-style-type: none"> ● Design and assemble parts to keep all catalog recommended tolerances for installation. ● Failure to hold the recommended tolerances can cause problems such as vibration, reduction in life, deterioration of precision and product failure.
 Caution	<p>Use the specified lubricant.</p> <ul style="list-style-type: none"> ● Using other than our recommended lubricant can reduce the life of the product. Replace the lubricant as recommended. ● Gearheads are factory lubricated. Do not mix installed lubricant with other kinds of grease.

Operational Precaution: Be certain to read the catalog before operating the equipment.	
 Caution	<p>Use caution when handling the product and parts.</p> <ul style="list-style-type: none"> ● Do not hit the gear or any part with a hammer. ● If you use the equipment in a damaged condition, the gearhead may not perform to catalog specifications. It can also cause problems including product failure.
 Caution	<p>Operate within the allowable torque range.</p> <ul style="list-style-type: none"> ● Do not apply torque exceeding the momentary peak torque. Applying excess torque can cause problems such as loosened bolts, generation of backlash and product failure. ● An arm attached directly to the output shaft that strikes a solid object can damage the arm or cause the output of the gearhead to fail.
 Caution	<p>Do not alter or disassemble the product or parts.</p> <ul style="list-style-type: none"> ● Harmonic Planetary® products are manufactured as matched sets. Catalog ratings may not be achieved if the component parts are interchanged.
 Caution	<p>Do not disassemble the products.</p> <ul style="list-style-type: none"> ● Do not disassemble and reassemble the products. Original performance may not be achieved.
 Warning	<p>Do not use your finger to turn the gear.</p> <ul style="list-style-type: none"> ● Do not insert your finger into the gear under any circumstances. The finger may get caught in the gear causing an injury.
 Caution	<p>Stop operating the system if any abnormality occurs.</p> <ul style="list-style-type: none"> ● Shut down the system promptly if any abnormal sound or vibration is detected, the rotation has stopped, an abnormally high temperature is generated, an abnormal motor current value is observed or any other anomalies are detected. Continuing to operate the system may adversely affect the product or equipment. ● Please contact our sales office or distributor if any anomaly is detected.
 Caution	<ul style="list-style-type: none"> ● Rust-proofing was applied before shipping. However, please note that rusting may occur depending on the customers' storage environment. ● Although black oxide finish is applied to some of our products, it does not guarantee that rust will not form.

Handling Lubricant	
 Warning	<p>Precautions on handling lubricants</p> <ul style="list-style-type: none"> ● Lubricant in the eye can cause inflammation. Wear protective glasses to prevent it from getting in your eye. ● Lubricant coming in contact with the skin can cause inflammation. Wear protective gloves when you handle the lubricant to prevent it from contacting your skin. ● Do not ingest (to avoid diarrhea and vomiting). ● Use caution when opening the container. There may be sharp edges that can cut your hand. Wear protective gloves. ● Keep lubricant out of reach of children.
 Caution	<p>Disposal of waste oil and containers</p> <ul style="list-style-type: none"> ● Follow all applicable laws regarding waste disposal. Contact your distributor if you are unsure how to properly dispose of the material. ● Do not apply pressure to an empty container. The container may explode. ● Do not weld, heat, drill or cut the container. This may cause residual oil to ignite or cause an explosion.
 Warning	<p>First-aid</p> <ul style="list-style-type: none"> ● Inhalation: Remove exposed person to fresh air if adverse effects are observed. ● Ingestion: Seek immediate medical attention and do not induce vomiting unless directed by medical personnel. ● Eyes: Flush immediately with water for at least 15 minutes. Get immediate medical attention. ● Skin: Wash with soap and water. Get medical attention if irritation develops.
 Caution	<p>Storage</p> <ul style="list-style-type: none"> ● Tightly seal the container after use. Store in a cool, dry, dark place. Keep away from open flames and high temperatures.
 Caution	<p>Disposal</p> <p>Please dispose of as industrial waste.</p> <ul style="list-style-type: none"> ● Please dispose of the products as industrial waste when their useful life is over.

Major Applications of Our Products



Metal Working Machines



Processing Machine Tools

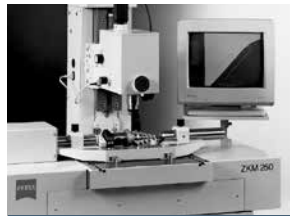

Measurement, Analytical and Test Systems



Medical Equipment



Telescopes

Source: National observatory of Inter-University Research Institute Corporation

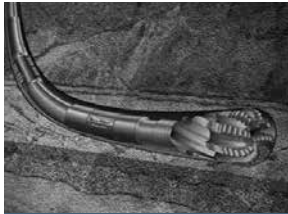

Energy

Courtesy of Halliburton/Sperry Drilling Services

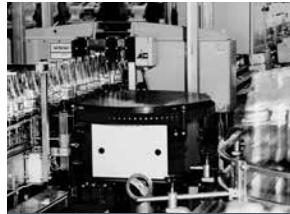

Crating and Packaging Machines



Communication Equipment



Space Flight Hardware

Rover image created by Dan Maas, copyrighted to Cornell and provided courtesy NASA/JPL-Caltech.

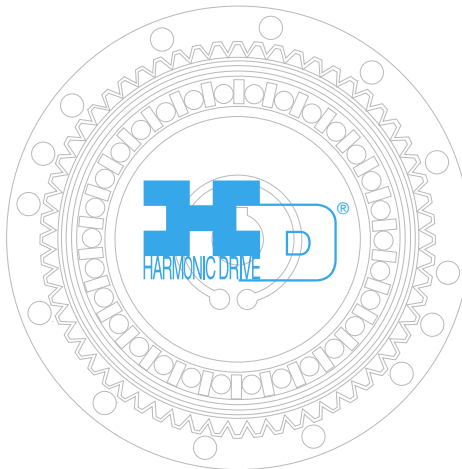

Glass and Ceramic Manufacturing Systems



Robots

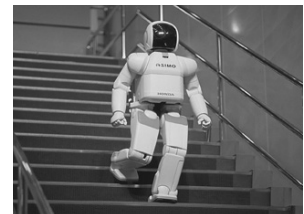

Humanoid Robots

Source: Honda Motor Co., Ltd.



Printing, Bookbinding and Paper Machines



Semiconductor Manufacturing Equip.



Optical Equipment



Machine Tools



Paper-making Machines



Flat Panel Display Manufacturing Equip.

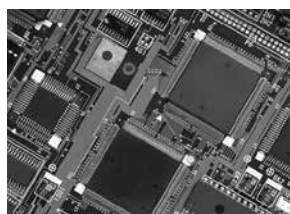

Printed Circuit Board Manufacturing Machines



Aerospace

Experts in Precision Motion Control

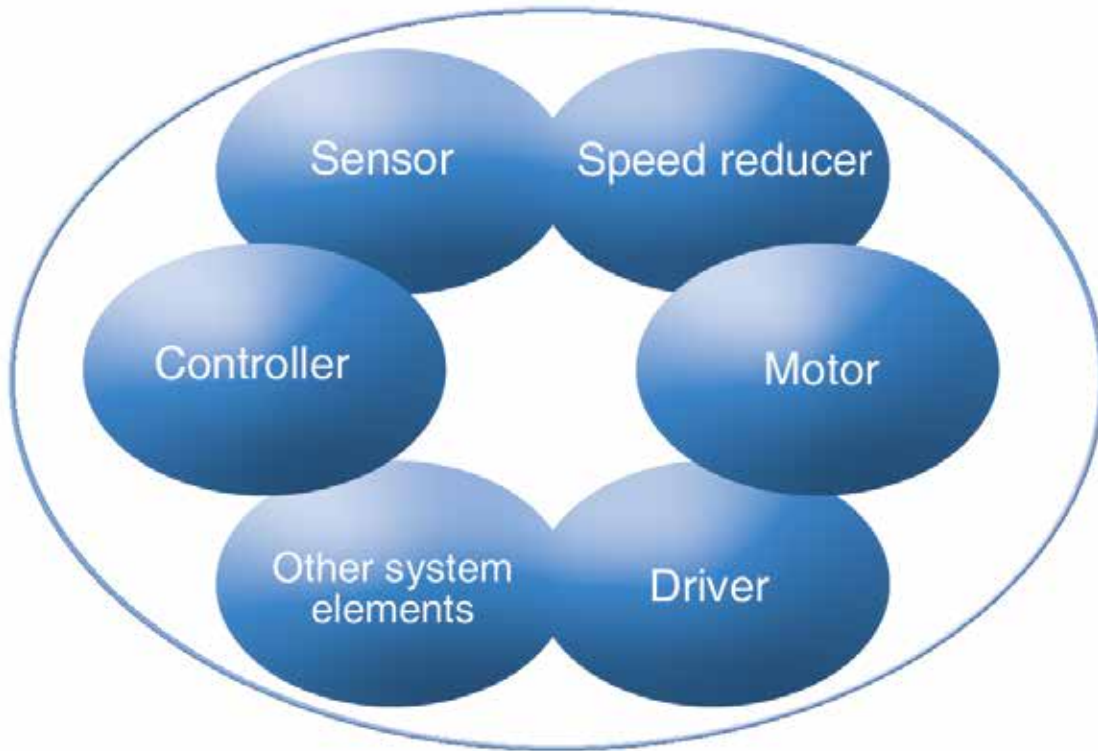

Other Products

HarmonicDrive® Gearing

HarmonicDrive® speed reducer delivers precise motion control by utilizing the strain wave gearing principle.

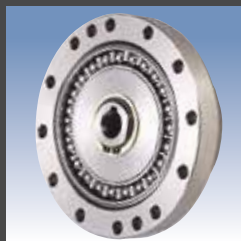

Rotary Actuators

High-torque actuators combine performance matched servomotors with HarmonicDrive® gears to deliver excellent dynamic control characteristics.

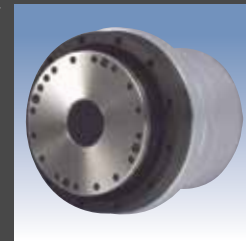

Linear Actuators

Compact linear actuators combine a precision lead screw and HarmonicDrive® gear. Our versatile actuators deliver both ultra precise positioning and high torque.



CSF Mini Gearheads

CSF mini gearheads provide high positioning accuracy in a super-compact package.

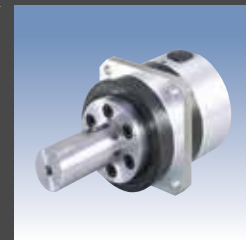

Harmonic Drive LLC

Boston US Headquarters

247 Lynnfield Street
Peabody, MA 01960

New York Sales Office

100 Motor Parkway
Suite 116
Hauppauge, NY 11788

California Sales Office

333 W. San Carlos Street
Suite 1070
San Jose, CA 95110

Chicago Sales Office

137 N. Oak Park Ave., Suite 410
Oak Park, IL 60301

T: 800.921.3332

T: 978.532.1800

F: 978.532.9406

www.HarmonicDrive.net

**In-Position
Technologies**
www.iptech1.com

Group Companies

Harmonic Drive Systems, Inc.
6-25-3 Minami-Ohi, Shinagawa-ku
Tokyo 141-0013, Japan

Harmonic Drive AG
Hoenbergstrasse, 14, D-6555
Limburg/Lahn Germany

Harmonic Drive®, Harmonic Gearhead®, Harmonic Planetary® and Quick Connect® are registered trademarks of Harmonic Drive LLC. All other trademarks are property of their respective owners.

