

aerospace
climate control
electromechanical
filtration
fluid & gas handling
hydraulics
pneumatics
process control
sealing & shielding

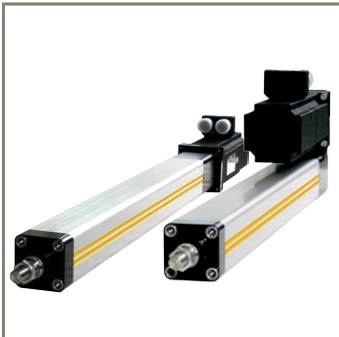

Parker Economic Servo Package P series

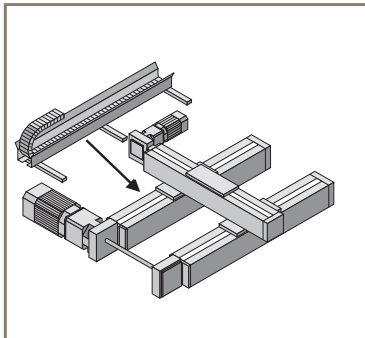

In-Position Technologies

www.iptech1.com | (877) 478-3241 | help@iptech1.com
ENGINEERING YOUR SUCCESS.



WARNING – USER RESPONSIBILITY

FAILURE OR IMPROPER SELECTION OR IMPROPER USE OF THE PRODUCTS DESCRIBED HEREIN OR RELATED ITEMS CAN CAUSE DEATH, PERSONAL INJURY AND PROPERTY DAMAGE.

- This document and other information from Parker-Hannifin Corporation, its subsidiaries and authorized distributors provide product or system options for further investigation by users having technical expertise.
- The user, through its own analysis and testing, is solely responsible for making the final selection of the system and components and assuring that all performance, endurance, maintenance, safety and warning requirements of the application are met. The user must analyze all aspects of the application, follow applicable industry standards, and follow the information concerning the product in the current product catalog and in any other materials provided from Parker or its subsidiaries or authorized distributors.
- To the extent that Parker or its subsidiaries or authorized distributors provide component or system options based upon data or specifications provided by the user, the user is responsible for determining that such data and specifications are suitable and sufficient for all applications and reasonably foreseeable uses of the components or systems.

Powerful servo solution

Main features

- Auto configuration (BiSS-C base)
- Multiple feedback interface
 - Serial(BiSS-C, EnDAT2.2, Tamagawa), Quadrature, SinCos
- User-friendly drive software
 - Step by step easy configuration
 - Pre-defined profile function
 - Auto tuning (real-time)
 - Various homing mode
 - Jog mode & Point to Point movement
 - 4 channel oscilloscope
 - Easy firmware update
- Programmable I/O
 - 1ms update rate
 - 16 channel digital input, 8 channel digital output
 - 2 channel analog input/output
- Various compatibility and application
 - ETH, ETT, OSPE
 - Rotary, Linear, DD servo motors and more



In-Position Technologies

www.iptech1.com | (877) 478-3241 | help@iptech1.com

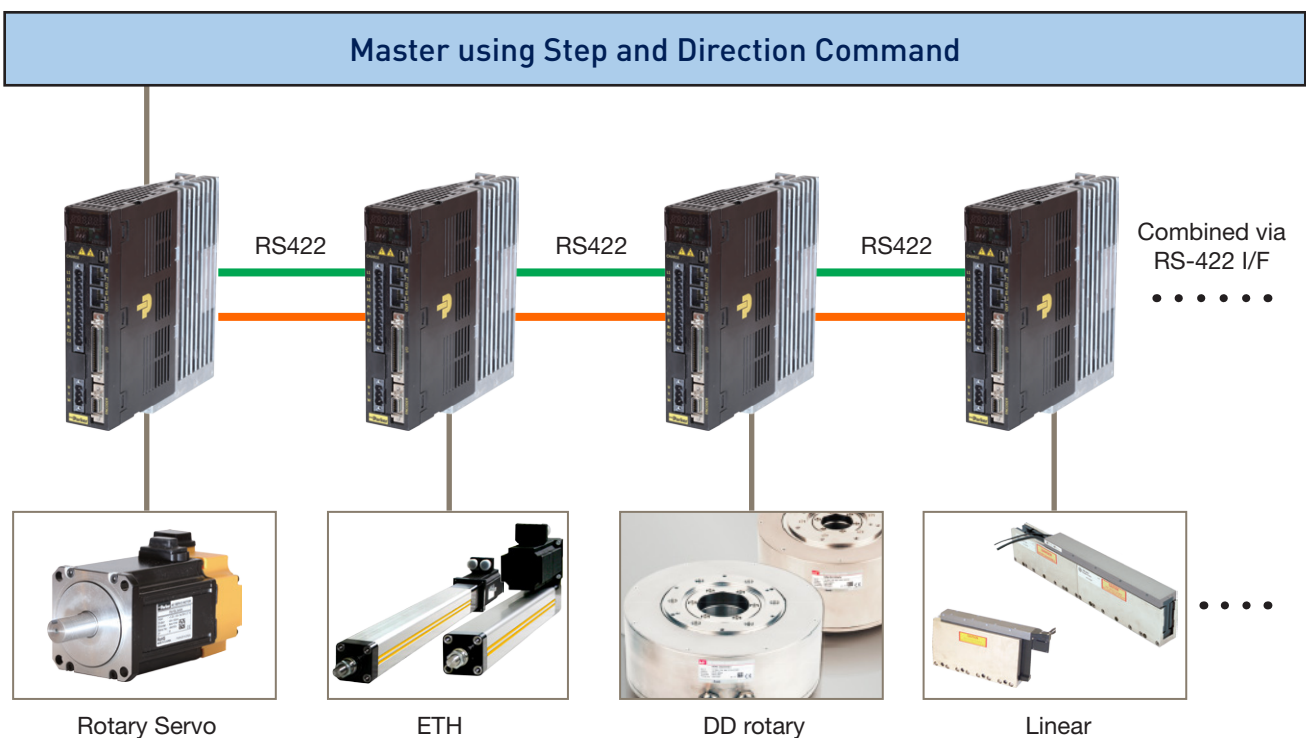

Pre-defined profile function

- Available 64 profiles

- Variable profile mode

- Absolute/Relative move

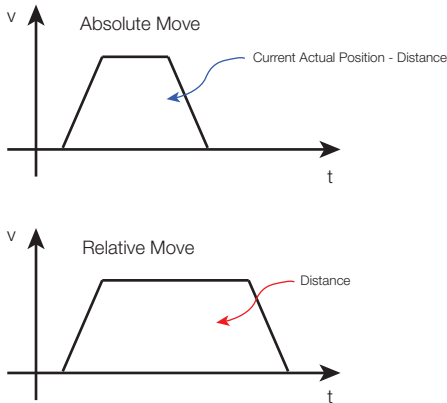

- Registration Absolute/Relative move

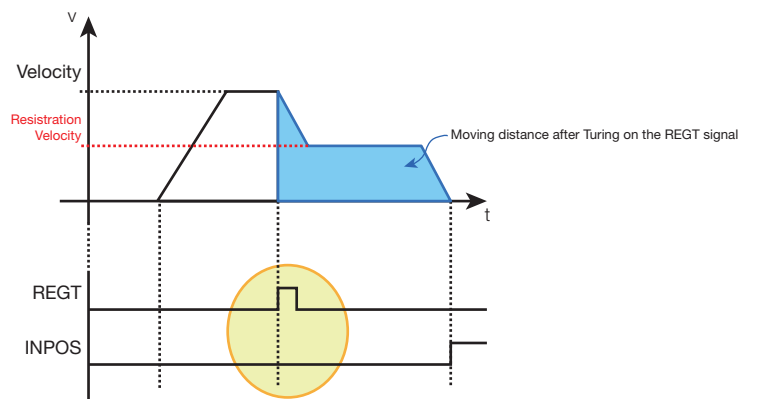

- Blending Absolute/Relative move

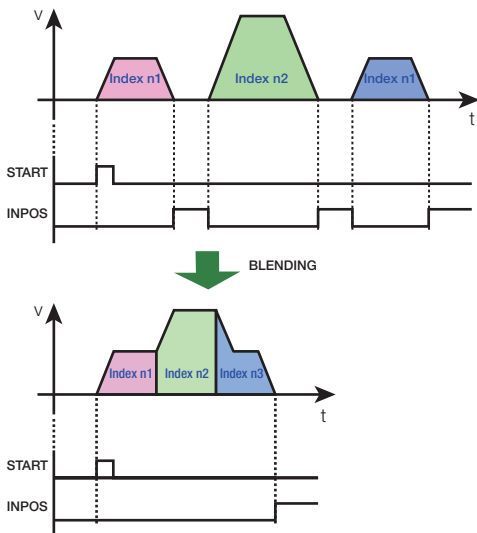

- Rotary Absolute/Relative/Shortest move

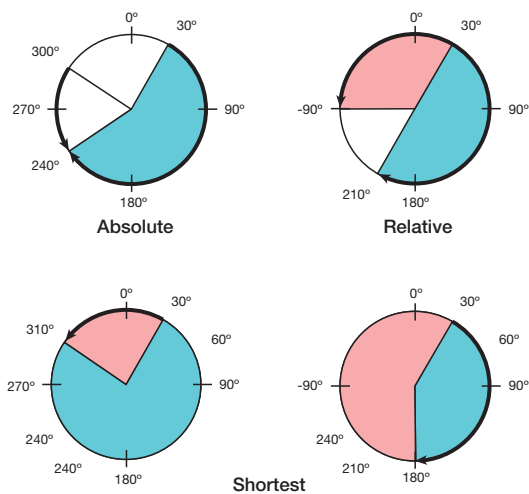

• **Loop method**

- Go to Next Index
- Wait for Start
- Stop

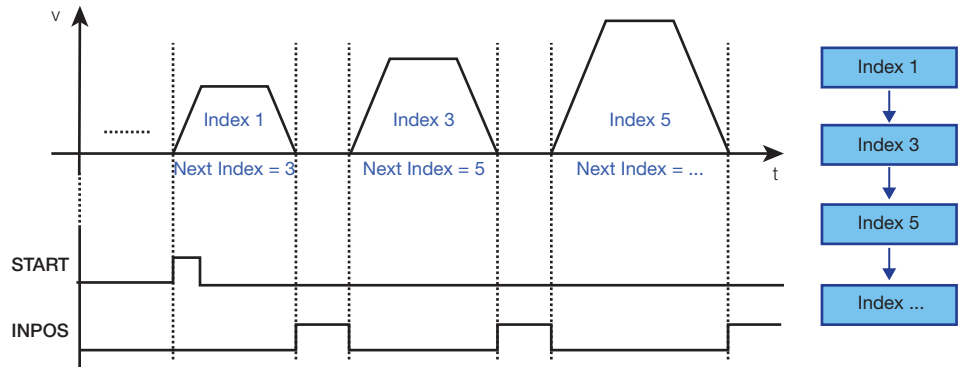

• **I/O control**

- Start, Stop, REG, EOS
- I/O0~5(Index number selecting & monitoring)



www.iptech1.com | (877) 478-3241 | help@iptech1.com

• **Multi-drop connection**

- RS422 serial communication interface for tasking ,test driving, gain turning, parameter setting and pre-defined position mode.
- This interface can be used for bus interface by using the multi-drop. (Max 32 axes)

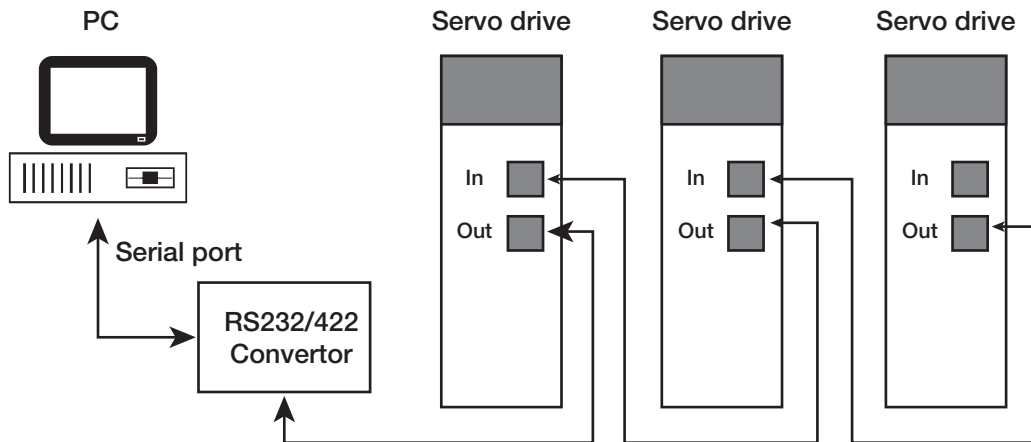

- The maximum packet size of MODBUS-RTU is 256 Byte

Item		Specification
Communication rule		ANSI/TIA/EIA-422 Standard
Communication protocol		MODBUS-RTU
Data Type	Data bit	8 bit
	Stop bit	1 bit
	Parity	None
Synchronous method		Asynchronous
Baud rate		9600/19200/38400/57600/115200 bit for second
Available distance		Max. 200m
Current consumption		Under 100mA

Servo Drive

Technical Data

Motor Output Power	PD-01	PD-02	PD-04	PD-08
Shaft Power @ Continuous Current	100 Watts	200 Watts	400 Watts	800 Watts
Shaft Power @ Peak Current	300 Watts	600 Watts	1,200 Watts	2,400 Watts
Drive Output Power				
Continuous Current (RMS)	1.4 Amps	1.7 Amps	3.0 Amps	5.2 Amps
Peak Current (RMS)	4.2 Amps	5.1 Amps	9.0 Amps	15.6 Amps
Bus Voltage	340VDC			
Drive Input Voltage	230 VAC, 3Ø, 50/60Hz			
Drive Control Voltage	230 VAC, 1Ø, 50/60Hz			

Motor Output Power	PD-10	PD-20	PD-35	
Shaft Power @ Continuous Current	1,000 Watts	2,000 Watts	3,500 Watts	
Shaft Power @ Peak Current	3,000 Watts	6,000 Watts	10,500 Watts	
Drive Output Power				
Continuous Current (RMS)	6.75 Amps	13.5 Amps	16.7 Amps	
Peak Current (RMS)	20.25 Amps	40.5 Amps	50.1 Amps	
Bus Voltage	340Vdc			
Drive Input Voltage	230 VAC, 3Ø, 50/60Hz			
Drive Control Voltage	230 VAC, 1Ø, 50/60Hz			

Performance				
Servo update	62.5µ seconds			
Accuracy	± 1 encoder count ; encoder dependent			
Communication	Sinusoidal			

Input				
Command	Step and direction, CW and CCW (Position control)			
Enable / Reset	12-24VDC			
Encoder	Quadrature Incremental encoder, BiSS-C (absolute) encoder, EnDAT 2.2, SinCos			

Output				
Fault	24VDC, 120mA			
Brake	Solid state, normally open, 1Amp @ 24VDC max			
Encoder Out	RS-422 compatible differential driver			

I/O				
Digital input	16-channel, +24V common, selectable			
Digital output	8-channel, Differential (Isolated), selectable			
Analog input	2-channel, ±10V (max.), 12bits			
Analog output	2-channel, ±10V (max.), selectable, 12bits			

Communications				
Type	USB 2.0 for firmware upload and drive configuration RS422 for operation interface			
Standard	ANSI/ TIA/ EIA-422 standard			
Baud Rate	9,600/ 19,200/ 38,400/ 57,600/ 115,200 bps			

Standards				
	CE, RoHS			

Environmental				
Temperature	0 - 50 °C (32 - 122 °F)			
Humidity	0 - 90% non-condensing			
Shock / Vibration	15g, 11msec half sign / 10-2,000Hz @ 2g			

In-Position Technologies

Dimensions

www.iptech1.com | (877) 478-3241 | help@iptech1.com

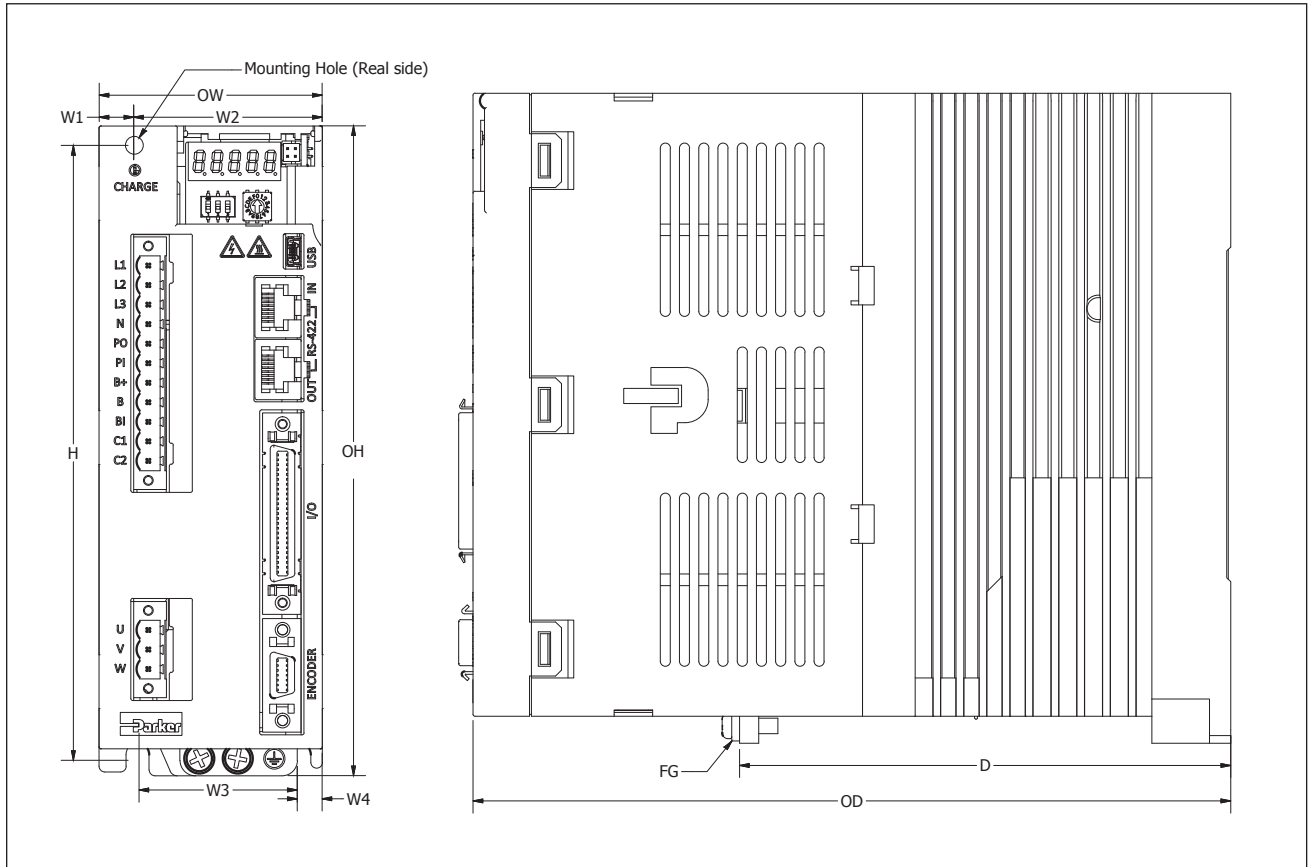

(Unit: mm)

		PD-01 ~ 04	PD-08 / 10	PD-20 / 35
H	Height	158	158	158
OH	Overall Height	169	169	169
OW	Overall Width	38	58	88
W1	Width 1	6	10	44
W2	Width 2	26	48	44
W3	Width 3	32	42	78
W4	Width 4	6	6	5
D	Depth	107.7	127.7	112.5
OD	Overall Depth	173	197	198

Note)

- This is for your reference only. For exact dimension, please refer to the drawing file available from http://solutions.parker.com/AUG_EM.
- Specification subject to change without notice.

Servo Motor (FAL Series Motor)

Technical Data

Motor Output Power		PM-FALR5AMxx	PM-FAL01AMxx	PM-FAL015AMxx
Rated Output Power		50 Watts	100 Watts	150 Watts
Motor Output Torque				
Rated Torque	N-m	0.16	0.32	0.48
	kgf-cm	1.62	3.25	4.87
Instantaneous Peak Torque	N-m	0.48	0.96	1.43
	kgf-cm	4.87	9.74	14.62
Motor Speed				
Rated Speed		3000 rpm		
Peak Speed		5000 rpm		
Moment of Inertia	kg-m ² x 10 ⁻⁴	0.02	0.05	0.06
	gf-cm-s ²	0.02	0.05	0.07
Available Moment of Load Inertia		Motor Inertia x 30		x 20
Position Feedback		BiSS-C Interface – 18bit		
Weight		0.4kg	0.5kg	0.7kg

Standards	CE
-----------	----

Environmental				
Temperature		0 - 40 °C		
Humidity		20-80% non-condensing		
Shock / Vibration		5G (49m/s ²)		

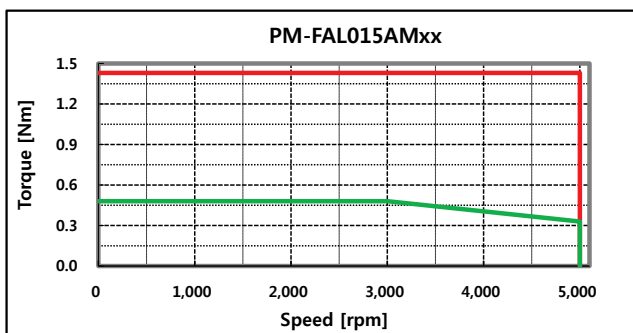
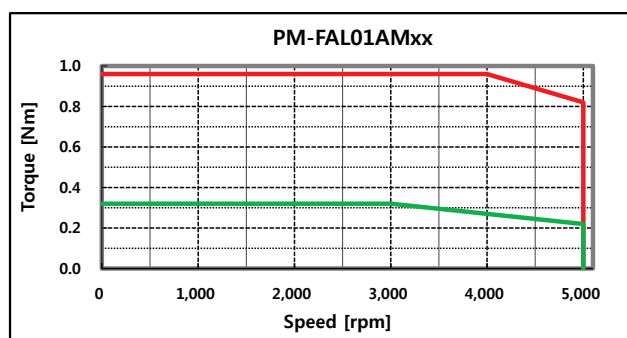
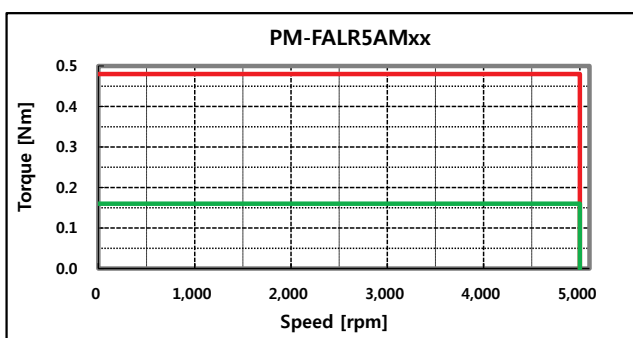

Dimensions

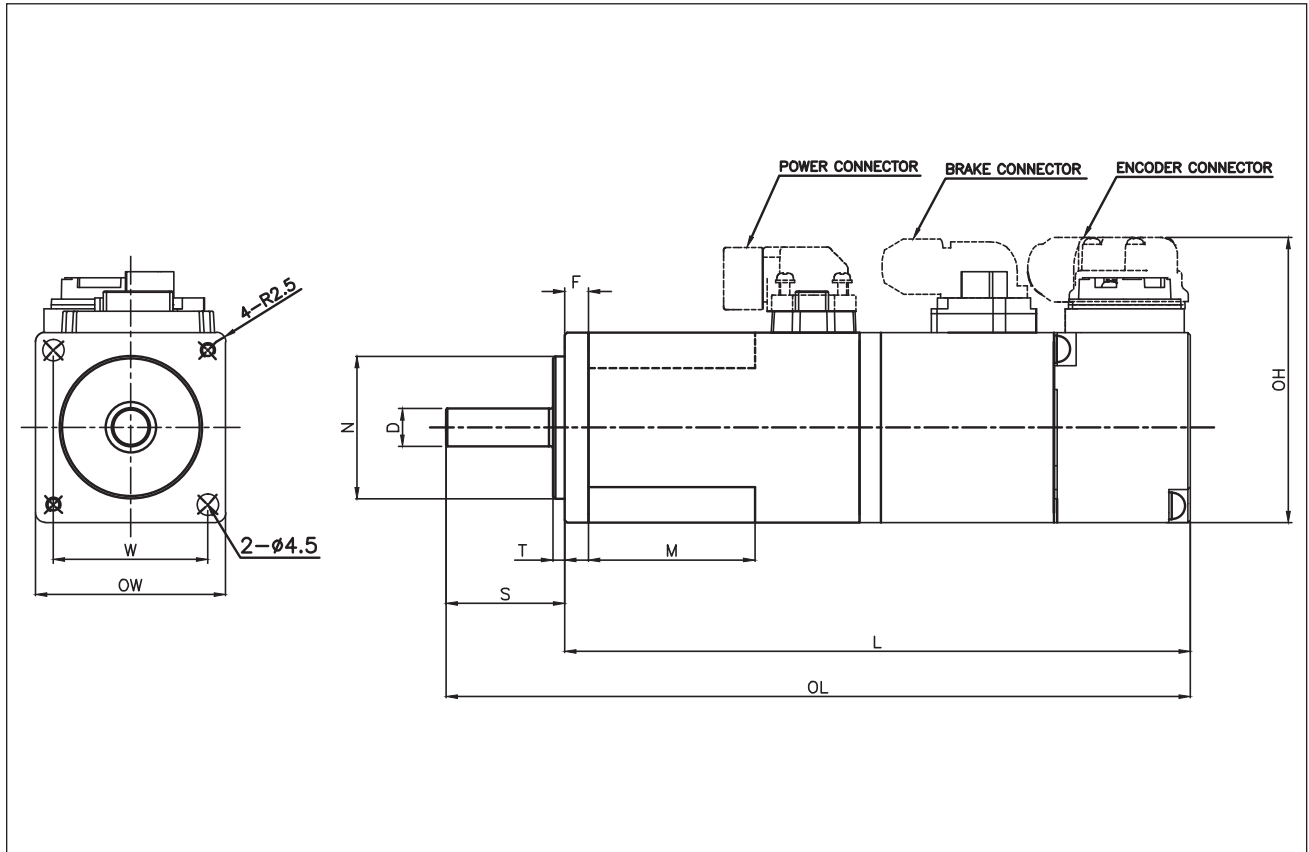

(Unit: mm)

	OW	OH	OL	L	N	W	D	F	M	S	T
PM-FALR5AMN	40	60	103.2	78.2	30	32.5	8	5	23	25	2.5
PM-FAL01AMN			120.2	95.2					35		
PM-FAL015AMN			140.2	115.2					35		
PM-FALR5AM2			139.6	114.6					23		
PM-FAL01AM2			156.6	131.6					35		
PM-FAL015AM2			176.6	151.6					35		

Note)

- FAL series are no-key type, Detail drawings and N-T curves are available at http://solutions.parker.com/AUG_EM
- Specification subject to change without notice.

In-Position
Technologies

Servo Motor (FBL Series Motor)

Technical Data

Motor Output Power		PM-FBL01AMxx	PM-FBL02AMxx	PM-FBL04AMxx
Rated Output Power		100 Watts	200 Watts	400 Watts
Motor Output Torque				
Rated Torque	N-m	0.32	0.64	1.27
	kgf-cm	3.25	6.50	12.99
Instantaneous Peak Torque	N-m	0.96	1.91	3.82
	kgf-cm	9.74	19.49	38.98
Motor Speed				
Rated Speed		3000 rpm		
Peak Speed		5000 rpm		
Moment of Inertia	kg-m ² x 10 ⁻⁴	0.09	0.15	0.25
	gf-cm-s ²	0.09	0.15	0.25
Available Moment of Load Inertia		Motor Inertia x 20		
Position Feedback		BiSS-C Interface – 19bit		
Weight		0.7kg	0.9kg	1.3kg

Standards	CE
-----------	----

Environmental				
Temperature		0 - 40 °C		
Humidity		20-80% non-condensing		
Shock / Vibration		5G (49m/s ²)		

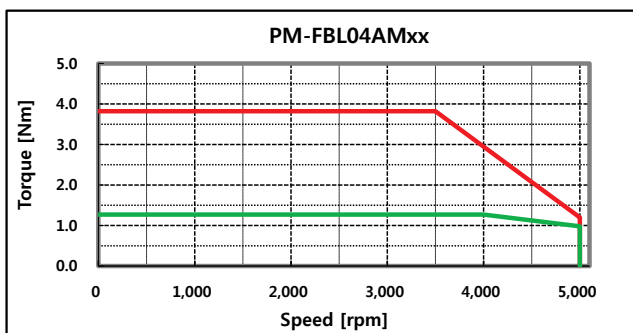
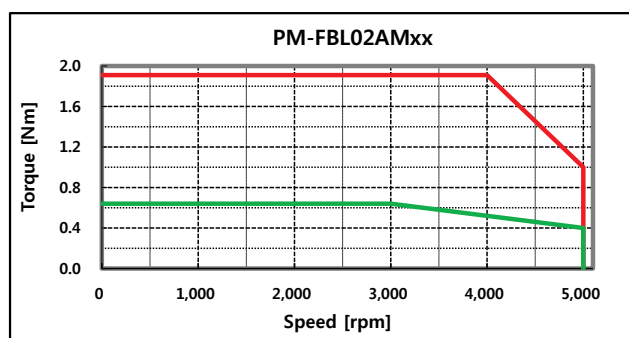
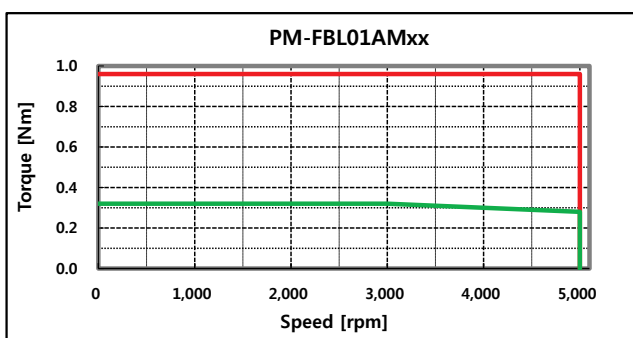

In-Position Technologies
 www.iptech1.com | (877) 478-3241 | help@iptech1.com

Dimensions

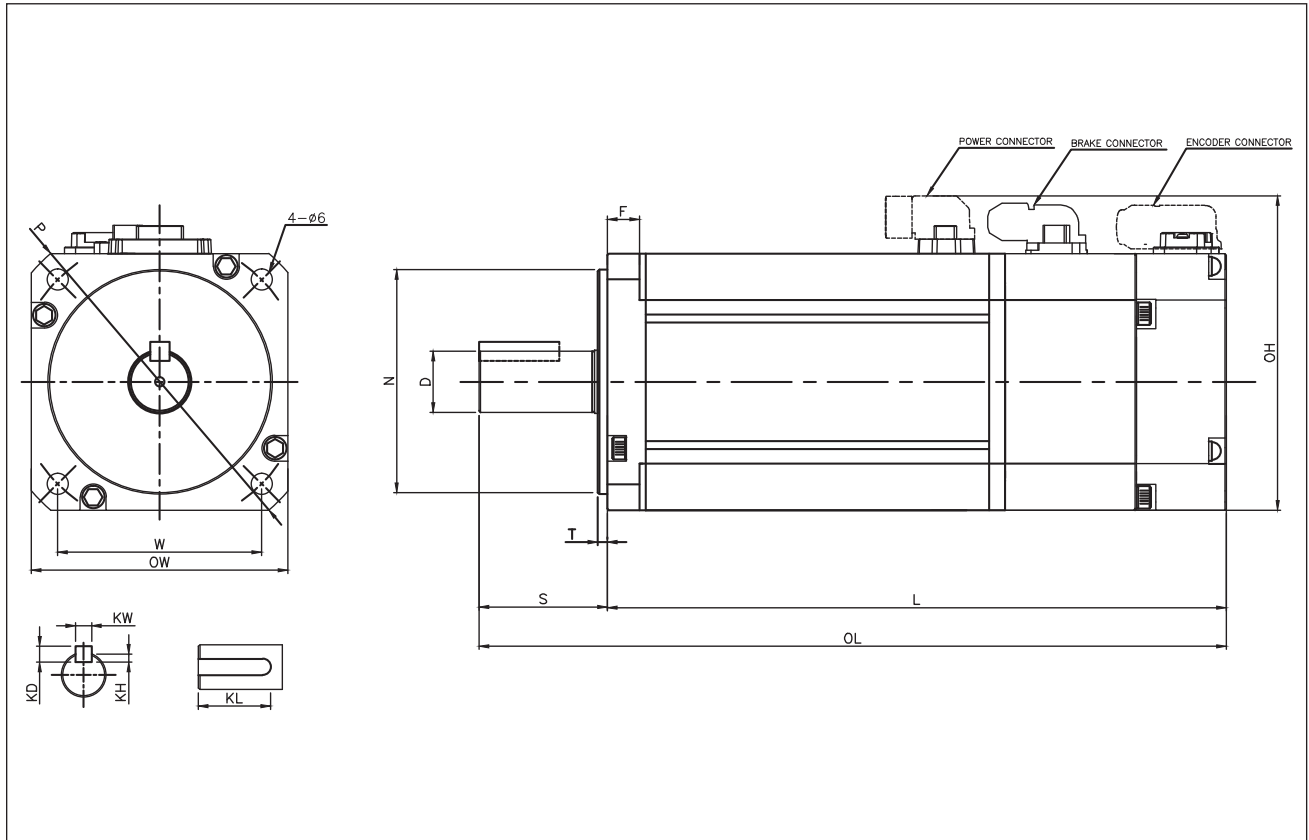

(Unit: mm)

	OW	OH	OL	L	N	W	D	F	S	T	KW	KH	KD	KL	P
PM-FBL01AMN	62	80	107.2	77.2	50	49.5	14	6	30	3	5	3	5	22.5	80
PM-FBL02AMN			118.2	88.2											
PM-FBL04AMN			138.2	108.2											
PM-FBL01AMK2			147.2	117.2											
PM-FBL02AMK2			158.2	128.2											
PM-FBL04AMK			178.2	148.2											

Note)

- Detail drawings and N-T curves are available at http://solutions.parker.com/AUG_EM
- Specification subject to change without notice.

In-Position Technologies

Servo Motor (FCL Series Motor)

Technical Data

Motor Output Power		PM-FCL04AMxx	PM-FCL06AMxx	PM-FCL08AMxx	PM-FCL10AMxx
Rated Output Power		400 Watts	600 Watts	750 Watts	1000 Watts
Motor Output Torque					
Rated Torque	N-m	1.27	1.91	2.39	3.18
	kgf-cm	13	19.5	24.36	32.5
Instantaneous Peak Torque	N-m	3.82	5.73	7.16	9.55
	kgf-cm	38.98	58.47	73.08	97.44
Motor Speed					
Rated Speed		3000 rpm			
Peak Speed		5000 rpm			
Moment of Inertia	kg-m ² x 10 ⁻⁴	0.5	0.88	1.25	1.62
	gf-cm-s ²	0.51	0.89	1.27	1.65
Available Moment of Load Inertia		Motor Inertia x 15			
Position Feedback		BiSS-C Interface – 19bit			
Weight		1.6kg	2.2kg	2.7kg	3.8kg

Standards	CE
-----------	----

Environmental				
Temperature		0 - 40 °C		
Humidity		20-80% non-condensing		
Shock / Vibration		5G (49m/s ²)		

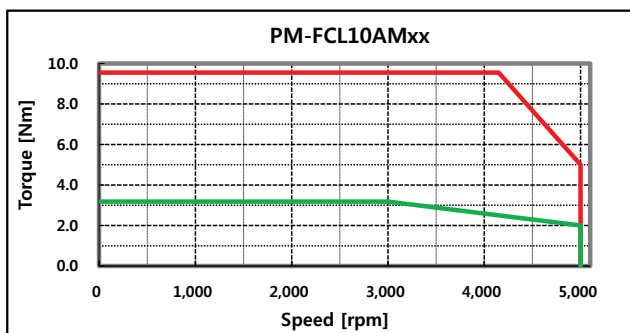
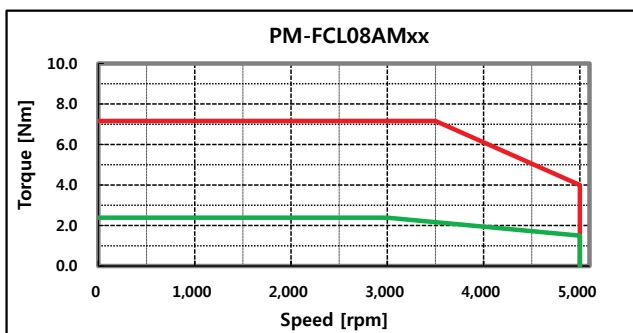
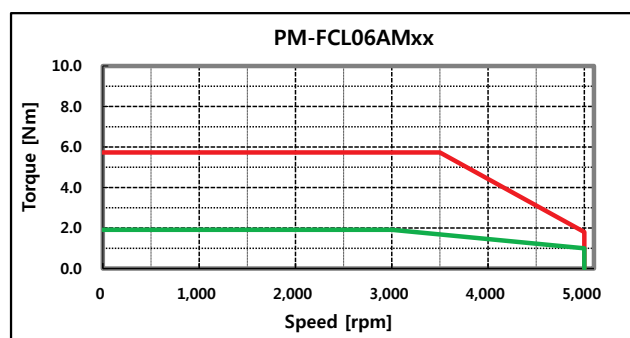
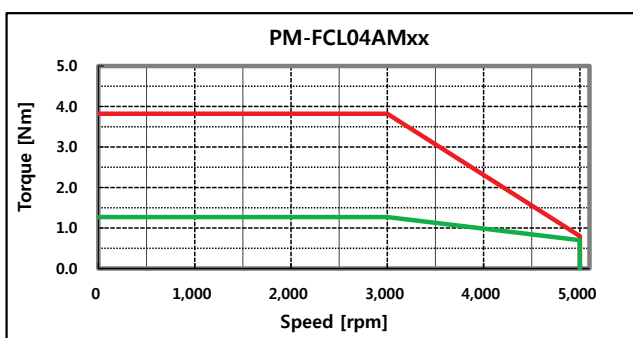

In-Position Technologies

www.iptech1.com | (877) 478-3241 | help@iptech1.com

Dimensions

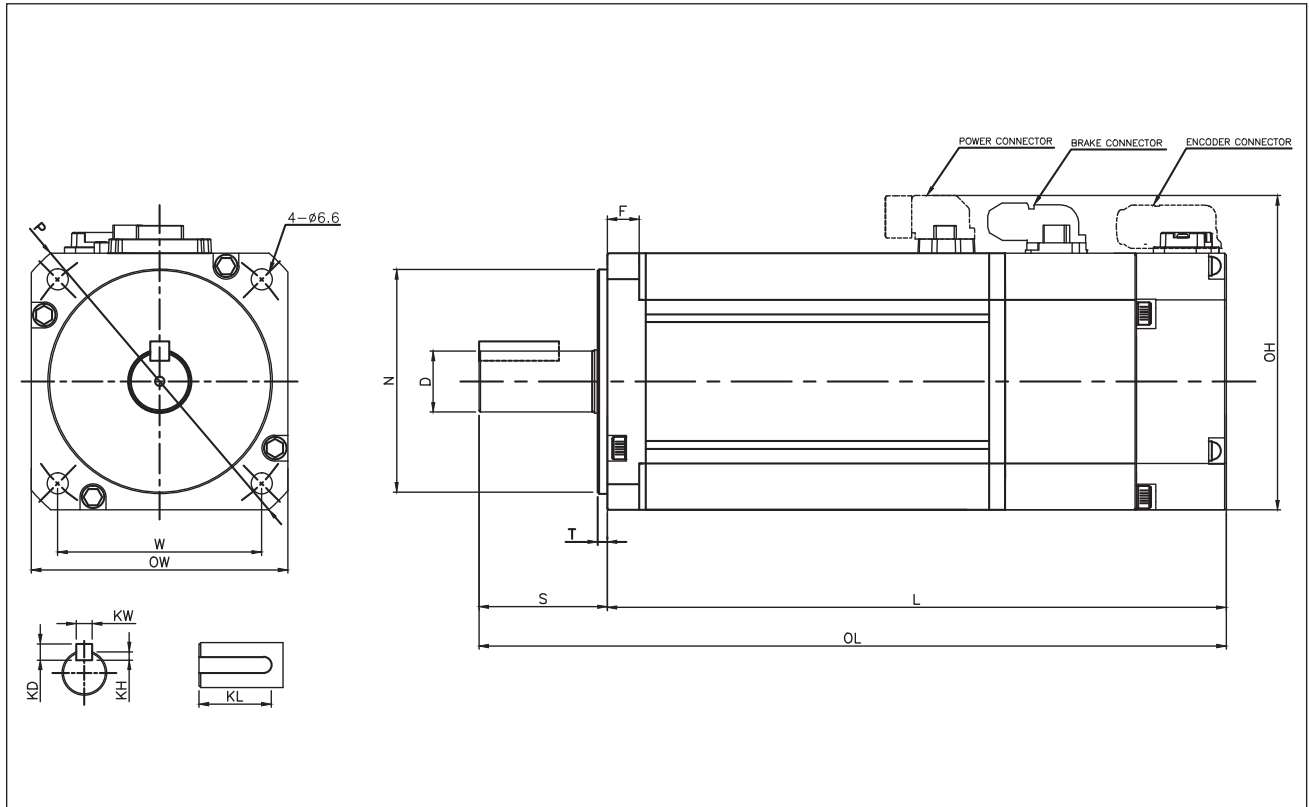

(Unit: mm)

	OW	OH	OL	L	N	W	D	F	S	T	KW	KH	KD	KL	P
PM-FCL03DMK PM-FCL04AMK	80	98	138.7	98.7	70	63.6	14	10	40	3	5	3	5	25	105
PM-FCL05DMK PM-FCL06AMK			156.7	116.7			19				6	3.5	6		
PM-FCL06DMK PM-FCL08AMK			174.7	134.7			14				5	3	5		
PM-FCL07DMK PM-FCL10AMK			192.7	152.7			19				6	3.5	6		
PM-FCL03AMK2 PM-FCL04AMK2			179	139			14				5	3	5		
PM-FCL05DMK2 PM-FCL06AMK2			197	157			19				6	3.5	6		
PM-FCL06DMK2 PM-FCL08AMK2			215	175			19				6	3.5	6		
PM-FCL07DMK2 PM-FCL10AMK2			233	193			19				6	3.5	6		

Note)

- Detail drawings and N-T curves are available at http://solutions.parker.com/AUG_EM
- Specification subject to change without notice.

Servo Motor (FE Series Motor)

Technical Data

Motor Output Power		PM-FE09AMxx	PM-FE15AMxx	PM-FE22AMxx	PM-FE30AMxx
Rated Output Power		900 Watts	1500 Watts	2200 Watts	3000 Watts
Motor Output Torque					
Rated Torque	N-m	2.86	4.77	7	9.55
	kgf-cm	29.2	48.7	71.4	97.4
Instantaneous Peak Torque	N-m	8.59	14.32	21.01	28.65
	kgf-cm	87.7	146.1	214.3	292.2
Motor Speed					
Rated Speed		3000 rpm			
Peak Speed		5000 rpm			
Moment of Inertia	kg-m ² x 10 ⁻⁴	5.66	10.18	14.62	19.04
	gf-cm-s ²	5.77	10.39	14.92	19.43
Available Moment of Load Inertia		Motor Inertia x 10			
Position Feedback		BiSS-C Interface – 19bit			
Weight		5.0kg	6.7kg	8.5kg	10.1kg

Standards	CE
-----------	----

Environmental				
Temperature		0 - 40 °C		
Humidity		20-80% non-condensing		
Shock / Vibration		5G (49m/s ²)		

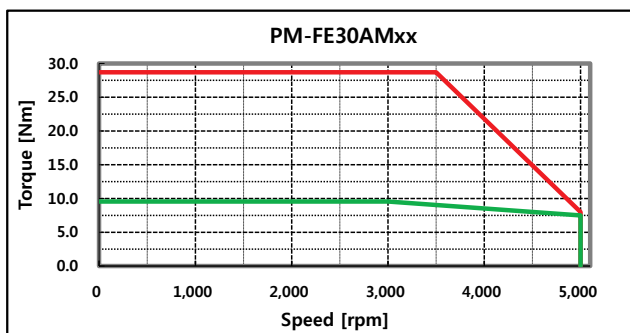
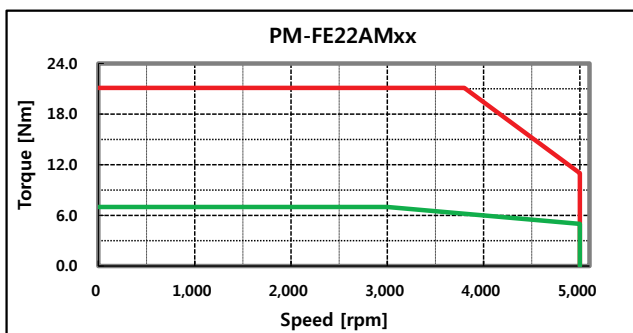
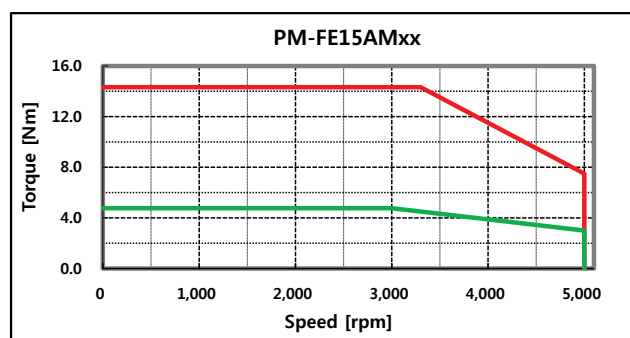
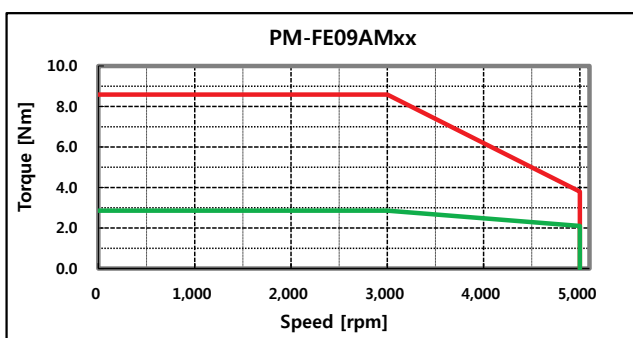

Dimensions

www.iptech1.com | (877) 478-3241 | help@iptech1.com

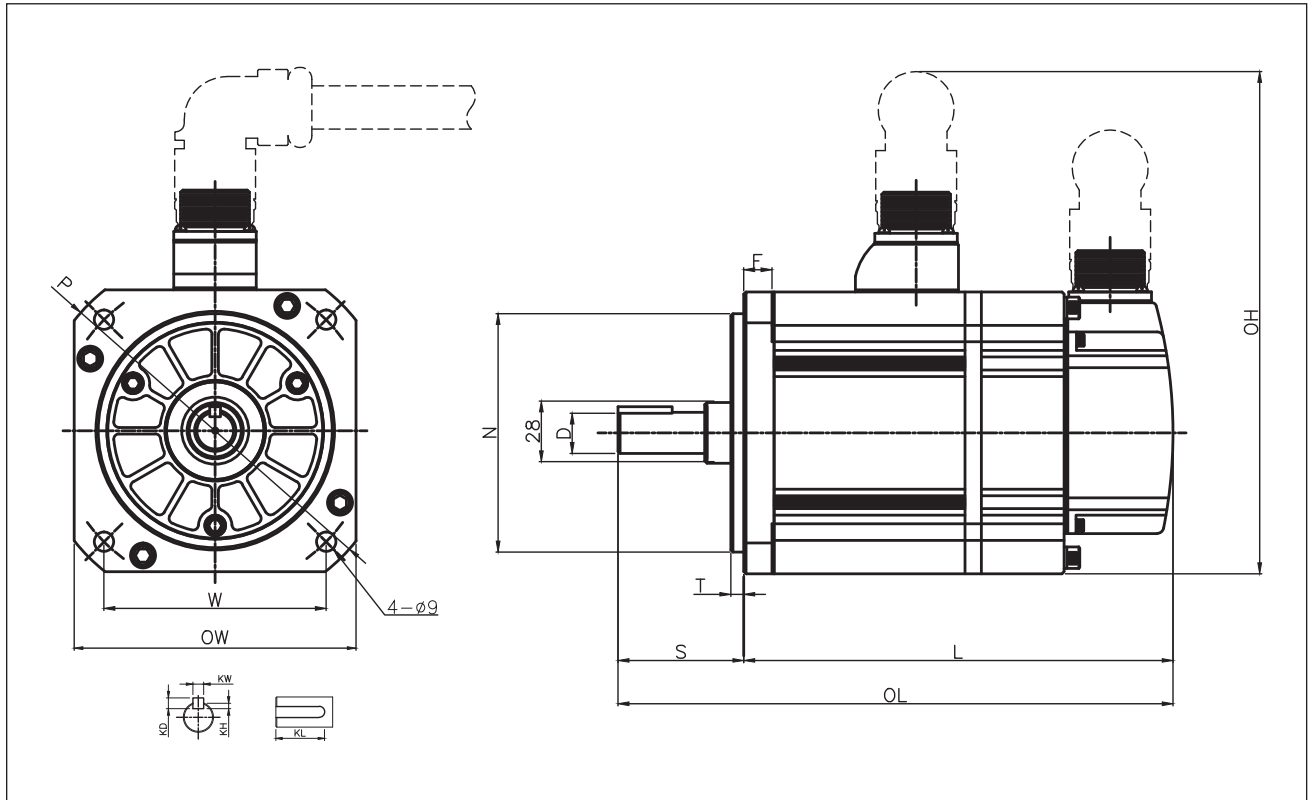

(Unit: mm)

	OW	OH	OL	L	N	W	D	F	S	T	KW	KH	KD	KL	P
PM-FE03MMK PM-FE05GMK PM-FE06DMK PM-FE09AMK	130	231.7	197.3	139.3	110	102.5	19	13	58	6	5	3	5	25	165
PM-FE06MMK PM-FE09GMK PM-FE11DMK PM-FE15AMK			217.3	159.3							6	3.5	6		
PM-FE09MMK PM-FE13GMK PM-FE16DMK PM-FE22AMK			237.3	179.3			22				4	7			
PM-FE12MMK PM-FE17GMK PM-FE22DMK PM-FE30AMK			255.3	197.3			24				8	7			
PM-FE03MMK2 PM-FE05GMK2 PM-FE06DMK2 PM-FE09AMK2			235.3	177.3			19				5	3	5		
PM-FE06MMK2 PM-FE09GMK2 PM-FE11DMK2 PM-FE15AMK2			255.3	197.3			22				6	3.5	6		
PM-FE09MMK2 PM-FE13GMK2 PM-FE16DMK2 PM-FE22AMK2			275.3	217.3			24				8	4	7		
PM-FE12MMK2 PM-FE17GMK2 PM-FE22DMK2 PM-FE30AMK2			293.3	235.3											

Note)

- Detail drawings and N-T curves are available at http://solutions.parker.com/AUG_EM
- Specification subject to change without notice.

Servo Motor (FF Series Motor)

Technical Data

Motor Output Power			PM-FF30AMxx	PM-FF35DMxx
	Rated Output Power		3000 Watts	3500 Watts
Motor Output Torque				
	Rated Torque	N-m	9.55	16.70
		kgf-cm	97.4	170.4
	Instantaneous Peak Torque	N-m	28.65	50.10
		kgf-cm	292.3	511.40
Motor Speed				
	Rated Speed		3000 rpm	2000 rpm
	Peak Speed		5000 rpm	3000 rpm
Moment of Inertia		kg-m ² x 10 ⁻⁴	27.96	46.56
		gf-cm-s ²	28.53	47.51
Available Moment of Load Inertia			Motor Inertia x 5	
Position Feedback			BiSS-C Interface – 19bit	
Weight			12.5kg	17.4kg

Standards	CE
-----------	----

Environmental		
	Temperature	0 - 40 °C
	Humidity	20-80% non-condensing
	Shock / Vibration	5G (49m/s ²)

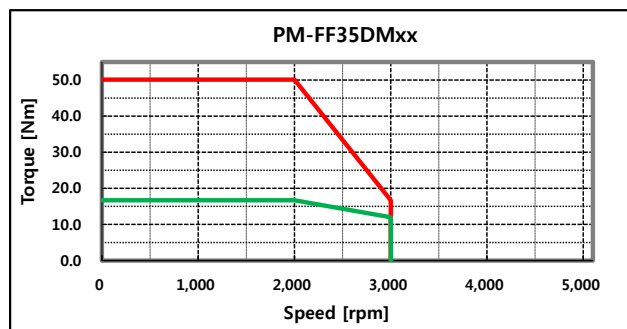
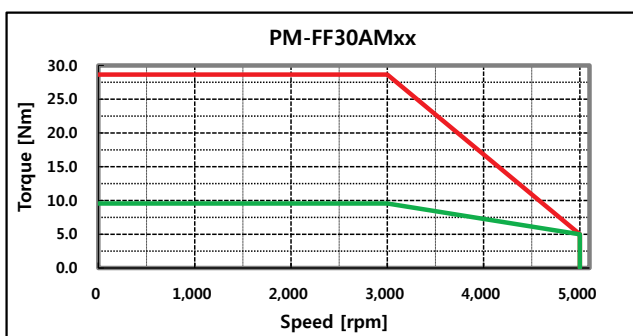

In-Position Technologies

www.iptech1.com | (877) 478-3241 | help@iptech1.com

In-Position Technologies

Dimensions

www.iptech1.com | (877) 478-3241 | help@iptech1.com

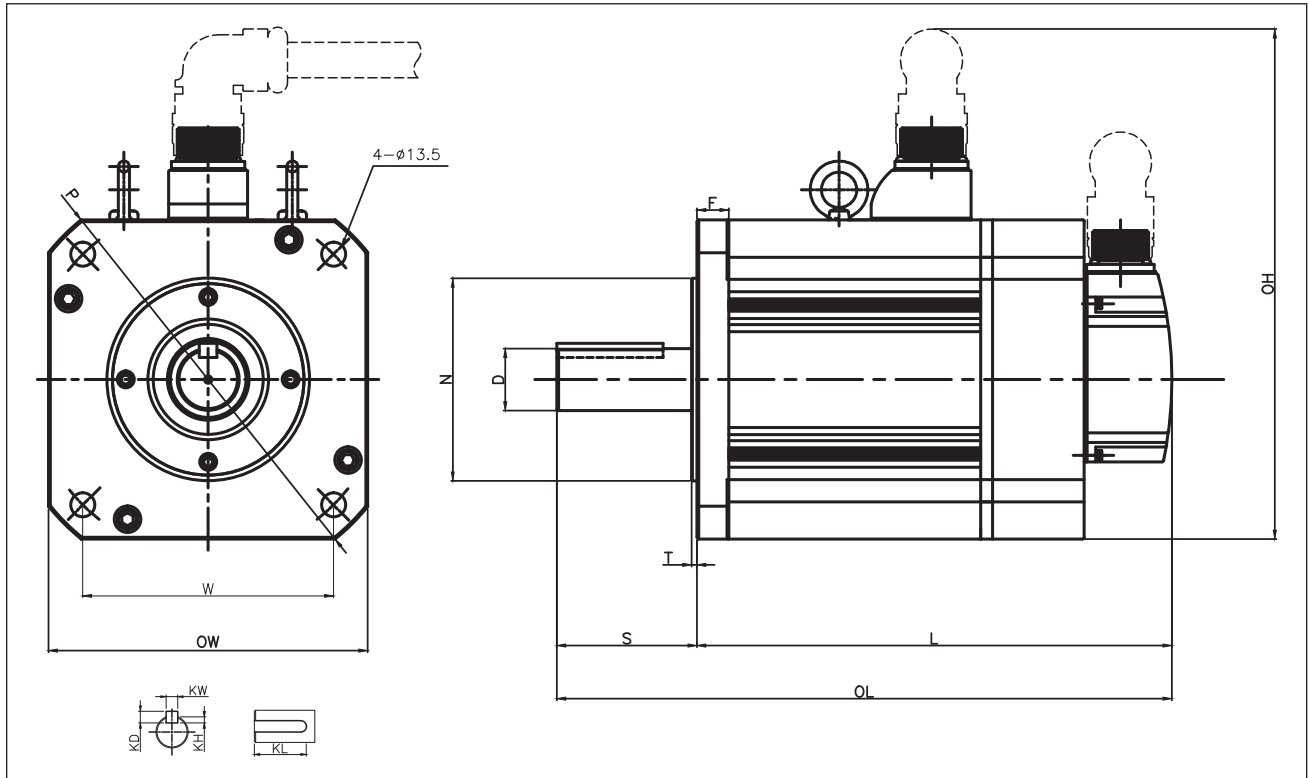

(Unit: mm)

	OW	OH	OL	L	N	W	D	F	S	T	KW	KH	KD	KL	P
PM-FF12MMK PM-FF20GMK PM-FF22DMK PM-FF30AMK	180	287.7	257.5	178.5	114.3	141.4	35	17	79	3	10	5	8	60	230
PM-FF20MMK PM-FF30GMK PM-FF35DMK			287.5	208.5											
PM-FF30MMK			331.5	252.5											
PM-FF12MMK2 PM-FF20GMK2 PM-FF22DMK2 PM-FF30AMK2			308.9	229.9											
PM-FF20MMK2 PM-FF30GMK2 PM-FF35DMK2			338.9	259.9											
PM-FF30MMK2			382.9	303.9											

Note)

- Detail drawings and N-T curves are available at http://solutions.parker.com/AUG_EM
- Specification subject to change without notice.

Ordering Code

Motor

P M-F	BL	04	A	M	K	2																																																							
<table border="1"> <thead> <tr><th colspan="2">Flange size</th></tr> </thead> <tbody> <tr><td>AL</td><td>40mm</td></tr> <tr><td>BL</td><td>62mm</td></tr> <tr><td>CL</td><td>80mm</td></tr> <tr><td>E</td><td>130mm</td></tr> <tr><td>F</td><td>180mm</td></tr> </tbody> </table>	Flange size		AL	40mm	BL	62mm	CL	80mm	E	130mm	F	180mm	<table border="1"> <thead> <tr><th colspan="2">Shaft Power</th></tr> </thead> <tbody> <tr><td>R5</td><td>50W</td></tr> <tr><td>01</td><td>100W</td></tr> <tr><td>02</td><td>200W</td></tr> <tr><td>...</td><td>....</td></tr> <tr><td>35</td><td>3,500W</td></tr> </tbody> </table>	Shaft Power		R5	50W	01	100W	02	200W	35	3,500W	<table border="1"> <thead> <tr><th colspan="2">Rated Speed (RPM)</th></tr> </thead> <tbody> <tr><td>A*</td><td>3,000rpm</td></tr> <tr><td>D</td><td>2,000rpm</td></tr> <tr><td>G</td><td>1,500rpm</td></tr> <tr><td>M</td><td>1,000rpm</td></tr> </tbody> </table>	Rated Speed (RPM)		A*	3,000rpm	D	2,000rpm	G	1,500rpm	M	1,000rpm	<table border="1"> <thead> <tr><th colspan="2">Encoder</th></tr> </thead> <tbody> <tr><td>M</td><td>BiSS-C Multi Turn</td></tr> </tbody> </table>	Encoder		M	BiSS-C Multi Turn	<table border="1"> <thead> <tr><th colspan="2">Shaft Key</th></tr> </thead> <tbody> <tr><td>N</td><td>No key</td></tr> <tr><td>K</td><td>Shaft key</td></tr> </tbody> </table>	Shaft Key		N	No key	K	Shaft key	<table border="1"> <thead> <tr><th colspan="2">Oil seal, Brake</th></tr> </thead> <tbody> <tr><td>Omit</td><td>No oil</td></tr> <tr><td colspan="2">Seal and Brake</td></tr> <tr><td>1</td><td>Oil seal</td></tr> <tr><td>2</td><td>Brake</td></tr> <tr><td>3</td><td>Both</td></tr> </tbody> </table>	Oil seal, Brake		Omit	No oil	Seal and Brake		1	Oil seal	2	Brake	3	Both
Flange size																																																													
AL	40mm																																																												
BL	62mm																																																												
CL	80mm																																																												
E	130mm																																																												
F	180mm																																																												
Shaft Power																																																													
R5	50W																																																												
01	100W																																																												
02	200W																																																												
...																																																												
35	3,500W																																																												
Rated Speed (RPM)																																																													
A*	3,000rpm																																																												
D	2,000rpm																																																												
G	1,500rpm																																																												
M	1,000rpm																																																												
Encoder																																																													
M	BiSS-C Multi Turn																																																												
Shaft Key																																																													
N	No key																																																												
K	Shaft key																																																												
Oil seal, Brake																																																													
Omit	No oil																																																												
Seal and Brake																																																													
1	Oil seal																																																												
2	Brake																																																												
3	Both																																																												

* : Standard

Drive

P D	-	04	P	-	XXX																
		<table border="1"> <thead> <tr><th colspan="2">Power</th></tr> </thead> <tbody> <tr><td>04</td><td>400W</td></tr> <tr><td>10</td><td>1,000W</td></tr> <tr><td>35</td><td>3,500W</td></tr> </tbody> </table>	Power		04	400W	10	1,000W	35	3,500W	<table border="1"> <thead> <tr><th colspan="2">Control Interface</th></tr> </thead> <tbody> <tr><td>P</td><td>Pulse type</td></tr> </tbody> </table>	Control Interface		P	Pulse type		<table border="1"> <thead> <tr><th colspan="2">Option code</th></tr> </thead> <tbody> <tr><td colspan="2">(ex. OEM customer/customized/etc.)</td></tr> </tbody> </table>	Option code		(ex. OEM customer/customized/etc.)	
Power																					
04	400W																				
10	1,000W																				
35	3,500W																				
Control Interface																					
P	Pulse type																				
Option code																					
(ex. OEM customer/customized/etc.)																					

Cable

APCS	-	P	N	03	LS																																														
		<table border="1"> <thead> <tr><th colspan="2">Cable</th></tr> </thead> <tbody> <tr><td>P</td><td>Power Cable</td></tr> <tr><td>E</td><td>Encoder Cable</td></tr> <tr><td>B</td><td>Brake Cable</td></tr> </tbody> </table>	Cable		P	Power Cable	E	Encoder Cable	B	Brake Cable	<table border="1"> <thead> <tr><th colspan="2">Cable type</th></tr> </thead> <tbody> <tr><td>F</td><td>Standard (Normal Application)</td></tr> <tr><td>N</td><td>High Flex (Robot Application)</td></tr> </tbody> </table>	Cable type		F	Standard (Normal Application)	N	High Flex (Robot Application)	<table border="1"> <thead> <tr><th colspan="2">Cable length</th></tr> </thead> <tbody> <tr><td>03</td><td>3m</td></tr> <tr><td>05</td><td>5m</td></tr> <tr><td>10</td><td>10m</td></tr> <tr><td>20</td><td>20m</td></tr> </tbody> </table>	Cable length		03	3m	05	5m	10	10m	20	20m	<table border="1"> <thead> <tr><th colspan="2">Option code</th></tr> </thead> <tbody> <tr><td>BxxxQS</td><td>FxL Series Brake Cable</td></tr> <tr><td>PxxxLS</td><td>FxL Series Power Cable</td></tr> <tr><td>PxxxHS</td><td>FE Series Power Cable</td></tr> <tr><td>PxxNB</td><td>FE Series Brake Type Power Cable</td></tr> <tr><td>PxxIS</td><td>FF Series(up to 3.5kW) Power Cable</td></tr> <tr><td>PxxPB</td><td>FF Series(up to 3.5kW) Brake Type Power Cable</td></tr> <tr><td>PxxJS</td><td>FF Series(up to 5.0kW) Power Cable</td></tr> <tr><td>PxxLB</td><td>FF Series(up to 5.0kW) Brake Type Power Cable</td></tr> <tr><td>ExxES1</td><td>FxL Series Multi-turn Encoder Cable</td></tr> <tr><td>ExxDS1</td><td>FE/FF Series Multi-turn Encoder Cable</td></tr> </tbody> </table>	Option code		BxxxQS	FxL Series Brake Cable	PxxxLS	FxL Series Power Cable	PxxxHS	FE Series Power Cable	PxxNB	FE Series Brake Type Power Cable	PxxIS	FF Series(up to 3.5kW) Power Cable	PxxPB	FF Series(up to 3.5kW) Brake Type Power Cable	PxxJS	FF Series(up to 5.0kW) Power Cable	PxxLB	FF Series(up to 5.0kW) Brake Type Power Cable	ExxES1	FxL Series Multi-turn Encoder Cable	ExxDS1	FE/FF Series Multi-turn Encoder Cable
Cable																																																			
P	Power Cable																																																		
E	Encoder Cable																																																		
B	Brake Cable																																																		
Cable type																																																			
F	Standard (Normal Application)																																																		
N	High Flex (Robot Application)																																																		
Cable length																																																			
03	3m																																																		
05	5m																																																		
10	10m																																																		
20	20m																																																		
Option code																																																			
BxxxQS	FxL Series Brake Cable																																																		
PxxxLS	FxL Series Power Cable																																																		
PxxxHS	FE Series Power Cable																																																		
PxxNB	FE Series Brake Type Power Cable																																																		
PxxIS	FF Series(up to 3.5kW) Power Cable																																																		
PxxPB	FF Series(up to 3.5kW) Brake Type Power Cable																																																		
PxxJS	FF Series(up to 5.0kW) Power Cable																																																		
PxxLB	FF Series(up to 5.0kW) Brake Type Power Cable																																																		
ExxES1	FxL Series Multi-turn Encoder Cable																																																		
ExxDS1	FE/FF Series Multi-turn Encoder Cable																																																		

OFFER OF SALE

The items described in this document and other documents and descriptions provided by Parker Hannifin Corporation, its subsidiaries and its authorized distributors ("Seller") are hereby offered for sale at prices to be established by Seller. This offer and its acceptance by any customer ("Buyer") shall be governed by all of the following Terms and Conditions. Buyer's order for any item described in its document, when communicated to Seller verbally, or in writing, shall constitute acceptance of this offer. All goods, services or work described will be referred to as "Products".

- 1. Terms and Conditions.** Seller's willingness to offer Products, or accept an order for Products, to or from Buyer is subject to these Terms and Conditions or any newer version of the terms and conditions found on-line at www.parker.com/saleterms/. Seller objects to any contrary or additional terms or conditions of Buyer's order or any other document issued by Buyer.
- 2. Price Adjustments; Payments.** Prices stated on Seller's quote or other documentation offered by Seller are valid for 30 days, and do not include any sales, use, or other taxes unless specifically stated. Unless otherwise specified by Seller, all prices are F.C.A. Seller's facility (INCOTERMS 2010). Payment is subject to credit approval and is due 30 days from the date of invoice or such other term as required by Seller's Credit Department, after which Buyer shall pay interest on any unpaid invoices at the rate of 1.5% per month or the maximum allowable rate under applicable law.
- 3. Delivery Dates;** Title and Risk; Shipment. All delivery dates are approximate and Seller shall not be responsible for any damages resulting from any delay. Regardless of the manner of shipment, title to any products and risk of loss or damage shall pass to Buyer upon placement of the products with the shipment carrier at Seller's facility. Unless otherwise stated, Seller may exercise its judgment in choosing the carrier and means of delivery. No deferment of shipment at Buyers' request beyond the respective dates indicated will be made except on terms that will indemnify, defend and hold Seller harmless against all loss and additional expense. Buyer shall be responsible for any additional shipping charges incurred by Seller due to Buyer's acts or omissions.
- 4. Warranty.** Seller warrants that the Products sold hereunder shall be free from defects in material or workmanship for a period of twelve months from the date of delivery to Buyer or 2,000 hours of normal use, whichever occurs first. The prices charged for Seller's products are based upon the exclusive limited warranty stated above, and upon the following disclaimer: DISCLAIMER OF WARRANTY: THIS WARRANTY COMPRISES THE SOLE AND ENTIRE WARRANTY PERTAINING TO PRODUCTS PROVIDED HEREUNDER. SELLER DISCLAIMS ALL OTHER WARRANTIES, EXPRESS AND IMPLIED, INCLUDING DESIGN, MERCHANTABILITY AND FITNESS FOR A PARTICULAR PURPOSE.
- 5. Claims;** Commencement of Actions. Buyer shall promptly inspect all Products upon delivery. No claims for shortages will be allowed unless reported to the Seller within 10 days of delivery. No other claims against Seller will be allowed unless asserted in writing within 30 days after delivery. Buyer shall notify Seller of any alleged breach of warranty within 30 days after the date the defect is or should have been discovered by Buyer. Any action based upon breach of this agreement or upon any other claim arising out of this sale (other than an action by Seller for an amount due on any invoice) must be commenced within 12 months from the date of the breach without regard to the date breach is discovered.
- 6. LIMITATION OF LIABILITY.** UPON NOTIFICATION, SELLER WILL, AT ITS OPTION, REPAIR OR REPLACE A DEFECTIVE PRODUCT, OR REFUND THE PURCHASE PRICE. IN NO EVENT SHALL SELLER BE LIABLE TO BUYER FOR ANY SPECIAL, INDIRECT, INCIDENTAL OR CONSEQUENTIAL DAMAGES ARISING OUT OF, OR AS THE RESULT OF, THE SALE, DELIVERY, NON-DELIVERY, SERVICING, USE OR LOSS OF USE OF THE PRODUCTS OR ANY PART THEREOF, OR FOR ANY CHARGES OR EXPENSES OF ANY NATURE INCURRED WITHOUT SELLER'S WRITTEN CONSENT, EVEN IF SELLER HAS BEEN NEGLIGENT, WHETHER IN CONTRACT, TORT OR OTHER LEGAL THEORY. IN NO EVENT SHALL SELLER'S LIABILITY UNDER ANY CLAIM MADE BY BUYER EXCEED THE PURCHASE PRICE OF THE PRODUCTS.
- 7. User Responsibility.** The user, through its own analysis and testing, is solely responsible for making the final selection of the system and Product and assuring that all performance, endurance, maintenance, safety and warning requirements of the application are met. The user must analyze all aspects of the application and follow applicable industry standards and Product information. If Seller provides Product or system options, the user is responsible for determining that such data and specifications are suitable and sufficient for all applications and reasonably foreseeable uses of the Products or systems.
- 8. Loss to Buyer's Property.** Any designs, tools, patterns, materials, drawings, confidential information or equipment furnished by Buyer or any other items which become Buyer's property, will be considered obsolete and may be destroyed by Seller after two consecutive years have elapsed without Buyer ordering the items manufactured using such property. Seller shall not be responsible for any loss or damage to such property while it is in Seller's possession or control.
- 9. Special Tooling.** A tooling charge may be imposed for any special tooling, including without limitation, dies, fixtures, molds and patterns, acquired to manufacture Products. Such special tooling shall be and remain Seller's property notwithstanding payment of any charges by Buyer. In no event will Buyer acquire any interest in apparatus belonging to Seller which is utilized in the manufacture of the Products, even if such apparatus has been specially converted or adapted for such manufacture and notwithstanding any charges paid by Buyer. Unless otherwise agreed, Seller shall have the right to alter, discard or otherwise dispose of any special tooling or other property in its sole discretion at any time.
- 10. Buyer's Obligation;** Rights of Seller. To secure payment of all sums due or otherwise, Seller shall retain a security interest in the goods delivered and this agreement shall be deemed a Security Agreement under the Uniform Commercial Code. Buyer authorizes Seller as its attorney to execute and file on Buyer's behalf all documents Seller deems necessary to perfect its security interest.
- 11. Improper use and Indemnity.** Buyer shall indemnify, defend, and hold Seller harmless from any claim, liability, damages, lawsuits, and costs (including attorney fees), whether for personal injury, property damage, patent, trademark or copyright infringement or any other claim, brought by or incurred by Buyer, Buyer's employees, or any other person, arising out of: (a) improper selection, improper application or other misuse of Products purchased by Buyer from Seller; (b) any act or omission, negligent or otherwise, of Buyer; (c) Seller's use of patterns, plans, drawings, or specifications furnished by Buyer to manufacture Product; or (d) Buyer's failure to comply with these terms and conditions. Seller shall not indemnify Buyer under any circumstance except as otherwise provided.
- 12. Cancellations and Changes.** Orders shall not be subject to cancellation or change by Buyer for any reason, except with Seller's written consent and upon terms that will indemnify, defend and hold Seller harmless against all direct, incidental and consequential loss or damage. Seller may change product features, specifications, designs and availability with notice to Buyer.
- 13. Limitation on Assignment.** Buyer may not assign its rights or obligations under this agreement without the prior written consent of Seller.
- 14. Force Majeure.** Seller does not assume the risk and shall not be liable for delay or failure to perform any of Seller's obligations by reason of circumstances beyond the reasonable control of Seller (hereinafter "Events of Force Majeure"). Events of Force Majeure shall include without limitation: accidents, strikes or labor disputes, acts of any government or government agency, acts of nature, delays or failures in delivery from carriers or suppliers, shortages of materials, or any other cause beyond Seller's reasonable control.
- 15. Waiver and Severability.** Failure to enforce any provision of this agreement will not waive that provision nor will any such failure prejudice Seller's right to enforce that provision in the future. Invalidation of any provision of this agreement by legislation or other rule of law shall not invalidate any other provision herein. The remaining provisions of this agreement will remain in full force and effect.
- 16. Termination.** Seller may terminate this agreement for any reason and at any time by giving Buyer thirty (30) days written notice of termination. Seller may immediately terminate this agreement, in writing, if Buyer: (a) commits a breach of any provision of this agreement (b) appoints a trustee, receiver or custodian for all or any part of Buyer's property (c) files a petition for relief in bankruptcy on its own behalf, or by a third party (d) makes an assignment for the benefit of creditors, or (e) dissolves or liquidates all or a majority of its assets.
- 17. Governing Law.** This agreement and the sale and delivery of all Products hereunder shall be deemed to have taken place in and shall be governed and construed in accordance with the laws of the State of Ohio, as applicable to contracts executed and wholly performed therein and without regard to conflicts of laws principles. Buyer irrevocably agrees and consents to the exclusive jurisdiction and venue of the courts of Cuyahoga County, Ohio with respect to any dispute, controversy or claim arising out of or relating to this agreement.
- 18. Indemnity for Infringement of Intellectual Property Rights.** Seller shall have no liability for infringement of any patents, trademarks, copyrights, trade dress, trade secrets or similar rights except as provided in this Section. Seller will defend and indemnify Buyer against allegations of infringement of U.S. patents, U.S. trademarks, copyrights, trade dress and trade secrets ("Intellectual Property Rights"). Seller will defend at its expense and will pay the cost of any settlement or damages awarded in an action brought against Buyer based on an allegation that a Product sold pursuant to this Agreement infringes the Intellectual Property Rights of a third party. Seller's obligation to defend and indemnify Buyer is contingent on Buyer notifying Seller within ten (10) days after Buyer becomes aware of such allegations of infringement, and Seller having sole control over the defense of any allegations or actions including all negotiations for settlement or compromise. If a Product is subject to a claim that it infringes the Intellectual Property Rights of a third party, Seller may, at its sole expense and option, procure for Buyer the right to continue using the Product, replace or modify the Product so as to make it noninfringing, or offer to accept return of the Product and return the purchase price less a reasonable allowance for depreciation. Notwithstanding the foregoing, Seller shall have no liability for claims of infringement based on information provided by Buyer, or directed to Products delivered hereunder for which the designs are specified in whole or part by Buyer, or infringements resulting from the modification, combination or use in a system of any Product sold hereunder. The foregoing provisions of this Section shall constitute Seller's sole and exclusive liability and Buyer's sole and exclusive remedy for infringement of Intellectual Property Rights.
- 19. Entire Agreement.** This agreement contains the entire agreement between the Buyer and Seller and constitutes the final, complete and exclusive expression of the terms of sale. All prior or contemporaneous written or oral agreements or negotiations with respect to the subject matter are herein merged.
- 20. Compliance with Law, U. K. Bribery Act and U.S. Foreign Corrupt Practices Act.** Buyer agrees to comply with all applicable laws and regulations, including both those of the United Kingdom and the United States of America, and of the country or countries of the Territory in which Buyer may operate, including without limitation the U. K. Bribery Act, the U.S. Foreign Corrupt Practices Act ("FCPA") and the U.S. Anti-Kickback Act (the "Anti-Kickback Act"), and agrees to indemnify and hold harmless Seller from the consequences of any violation of such provisions by Buyer, its employees or agents. Buyer acknowledges that they are familiar with the provisions of the U. K. Bribery Act, the FCPA and the Anti-Kickback Act, and certifies that Buyer will adhere to the requirements thereof. In particular, Buyer represents and agrees that Buyer shall not make any payment or give anything of value, directly or indirectly to any governmental official, any foreign political party or official thereof, any candidate for foreign political office, or any commercial entity or person, for the purpose of influencing such person to purchase products or otherwise benefit the business of Seller.

Parker Asia Pacific

China

Sales Office

Shanghai office, 86-21-28995000
Parker Hannifin Motion&Control Co. Ltd.
280 Yunqiao Road, Jin Qiao Export Processing Zone,
Shanghai 201206, China

Sales Office

Guangzhou Office, 86 20 3878 1583
Parker Hannifin Motion&Control Co. Ltd.
Room 1706, Goldlion Tower, No. 138, Ti Yu East Road,
Guangzhou, 510620, China

Sales Office

Beijing office, 86-10-6561-0520
Parker Hannifin Motion&Control Co. Ltd.
Suite B2109, 21st Floor, Hanwei Plaza, 7 Guanghua
Road, Chaoyang District, Beijing, 100004, China

Automation Division

WUXI plant, 86-510-8116-7000
Parker Hannifin Motion and Control (Wuxi) Company Ltd.
No.200, Furong Zhong Si Lu, Xishan Economic
Development Zone, Wuxi 214101, Jiangsu, China

Japan

Sales Office

Totsuka Office, 81-45-870-1510
Parker Hannifin Japan Ltd.
626 Totsuka-cho, Totsuka-ku, Yokohama-shi,
Kanagawa, 244-0003 Japan

Automation Division

Asahi Plant, 81-479-64-2282
Kuroda Pneumatics Ltd.
10243 Kamakazu, Asahi-shi, Chiba 289-2505 Japan

Korea

Sales Office

Ga San Office, 822-6344-0100
Parker Hannifin Korea Automation Office
13F Jei Platz B/D , 459-11 Gasan-dong, Geumcheon-
gu, Seoul

Automation Division

Jang An Plant, 82 31-359-0700
Parker Korea Ltd.
759-10 Geumui-ri, Jangan-myeon, Hwaseong-si,
Gyeonggi-do, 445-941, Korea

India

Sales Office

PHI Chennai Sales office, 91-44-43910799
Parker Hannifin India Private. Limited,
Plot no. P41/2, Eight Avenue, Domestic Tariff Area,
Mahindra world city, Chengalpattu, Kanchipuram District,
Pin : 603002, Tamil Nadu, India

Automation Division

PHI Chennai MWC Plant, 91-44-43910703
Parker Hannifin India Private. Limited,
Plot no. P41/2, Eight Avenue, Domestic Tariff Area,
Mahindra world city, Chengalpattu, Kanchipuram District,
Pin : 603002, Tamil Nadu, India

Taiwan

Sales Office

Taipei Office, 886-2-22988987
Parker Hannifin Taiwan Co., Ltd.
No.19, Wu Chiuan 2nd Road, Wuku Industrial Park, New Taipei
City, Taiwan 248

Thailand

Sales Office

Bangkok Office, 66-2-186-7000
Parker Hannifin (Thailand) Co., Ltd.
1265 Rama9 Road, Suanluang, Bangkok 10250

Singapore

Sales Office

65-6887-6300
Parker Hannifin Singapore Pte Ltd.
No.11, Fourth Chin Bee Road, Singapore 619702

Malaysia

Sales Office

Selangor Office, 603-7849-0800
Parker Hannifin Industrial (M) Sdn Bhd
No. 11, Persiaran Pasak bumi, Seksyen U8, Bukit Jelutong
Industrial Park, 40150 Shah Alam, Selangor

Indonesia

Sales Office

62-21-7588-1906
Parker Hannifin (Indonesia Rep Office)
Techno Park Block G3/16 BSD (Bumi Serpong Damai)
Tangerang, 15314 Indonesia

Vietnam

Sales Office

84 8 377 546 51
Parker Hannifin Vietnam Co., Ltd.
7-9 Road 65, Tan Quy Dong Residential Area, Tan Phong Ward,
District 7, Ho Chi Minh City, Vietnam

Australia

Sales Office

61-(0)2-9634-7777
Parker Hannifin (Australia) Pty Limited
9 Carrington Road, Castle Hill, NSW 2154

This catalogue is offered to you by;

In-Position Technologies

www.iptech1.com | (877) 478-3241 | help@iptech1.com



Parker Korea Ltd.

23, Jangangongdan 1-gil Jangan-myeon,
Hwaseong-si Gyeonggi-do, 445-941, Korea
Tel.: +82-31-359-0700
Fax: +82-31-359-0780
www.parker.com