

DATAVS2

 **DATALOGIC**



The DataVS2 vision sensor series presents all the characteristics to solve machine vision applications in a flexible and intuitive way.

DataVS2 is a completely embedded device: the optic, the LED illuminator and the electronics are included in an extremely compact housing. The sensor is configured via PC through Ethernet communication. The configuration software is supplied with the product and it has been developed in order to lead the customer through the configuration process step by step.

DataVS2 is available in four different versions according to the installed control tools: Object Recognition (OBJ), Advanced Object Recognition (AOR), Identification (ID) and Professional (PRO).

Many different control typologies are available: brightness, contrast, position, width, count, pattern match, contour match, 360° pattern match, barcode and datamatrix reader, OCV, 360° contour match & counter, 360° defect finder.

HIGHLIGHTS

- Flexible and intuitive setup via PC through Ethernet
- Memorisation of 20 inspections
- 14 different controls
- 360° Contour Match for Professional models
- Logical operators: AND, OR, NOT, NAND, NOR, ecc.
- TURBO mode to double elaboration speed
- VSM compatibility
- Inspection & Identification functionalities together available on Professional models

APPLICATION

DataVS2 is ideal for the control of text presence in overprinting, product completeness before packaging, logo position on cosmetic bottles, correct stamp on post envelopes, liquid level inside a plastic bottle, correct product orientation on a conveyor belt, barcode and datamatrix reading.

Stamp control



Part orientation



Overprinting

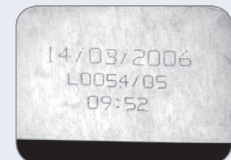

Level control

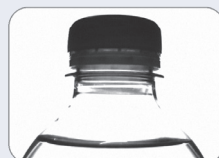

Logo control



Barcode & Datamatrix



**In-Position
Technologies**

www.iptech1.com | (877) 478-3241 | help@iptech1.com

DIMENSIONS



The extremely compact size of the DATAVS sensors is not an obstacle for the full integration of all the elements for a reliable image-based control.

- Compact housing
- Red or Infrared LED illuminator
- Selectable lenses
- Focus knob
- Standard M12 connectors
- Ethernet communication
- 3+1 PNP outputs
- 4 signalling LEDs: output1, output2, power supply, communication
- Teach push-button
- 640x480 pixel greyscale CMOS image sensor

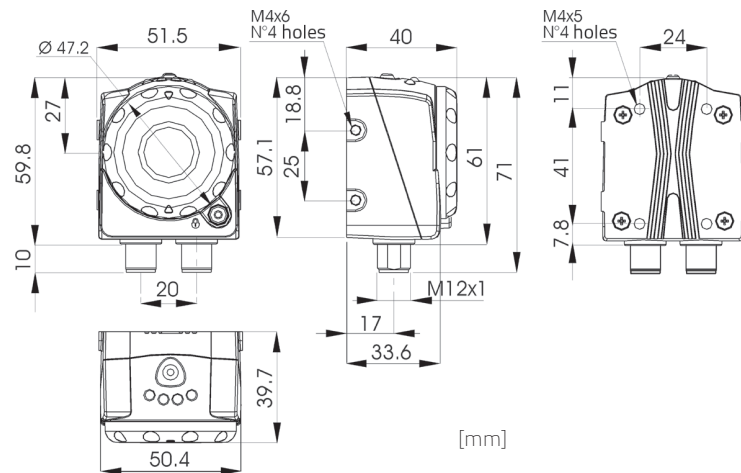

INDICATORS AND SETTINGS

Teach push-button with double function:

- reference image update
- recovery mode



- A** Power supply, green
- B** Digital output 1, orange
- C** Digital output 2, orange
- D** Network connection, green

CONNECTIONS



M12 4-pole Ethernet

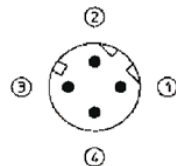

- 1 = white/orange = RX+
- 2 = white/green = TX+
- 3 = orange = RX-
- 4 = green = TX-

M12 8-pole (power supply and I/O)

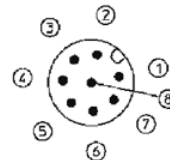

OBJ and AOR models

- 1 = white = digital input 1
- 2 = brown = 24 Vdc
- 3 = green = configurable output
- 4 = yellow = output 1
- 5 = grey = output 2
- 6 = pink = output 3
- 7 = blue = GND
- 8 = red = external trigger

ID and PRO models

- 1 = white = RS232 RX
- 2 = brown = 24 Vdc
- 3 = green = configurable output
- 4 = yellow = output 1
- 5 = grey = output 2
- 6 = pink = RS232 TX
- 7 = blue = GND
- 8 = red = external trigger

TECHNICAL DATA

Power supply:	24 Vdc ±10 %
Ripple:	1 Vpp max with illuminator 2 Vpp without illuminator
Consumption:	100 mA at 24 Vdc (without illuminator)
Output type:	3+1 PNP
Output current:	100 mA max
Saturation voltage:	< 2 V
Network interface:	M12 4-pole Ethernet 10/100 Mbs
Serial interface:	RS232 (only ID and PRO models)
External illuminator interface:	Strobe signal (24 V PNP N.O.)
Frame rate:	60 fps
Optics:	integrated (6 mm / 8 mm / 12 mm / 16 mm)
Illuminator:	Red or Infrared
Setting:	TEACH push-button
Indicators:	4 LED
Connections:	M12 8 pole A-code M12 4 pole D-code
Mechanical protection:	IP50
Protection devices:	A, B
Housing material:	aluminium alloy / ABS
Weight:	125 g
Operating temperature:	-10 ... +50°C
Storage temperature:	-25 ... +70°C



FIELD OF VIEW

OPERATING DISTANCE (MM)	FIELD OF VIEW (WIDTH X HEIGHT) IN MM			
	DATAVS2-06-XX-XXX	DATAVS2-08-XX-XXX	DATAVS2-12-XX-XXX	DATAVS2-16-XX-XXX
50	42 x 30	25 x 20	17 x 12	-
80	60 x 41	40 x 30	25 x 20	-
110	80 x 55	55 x 40	33 x 25	-
140	98 x 69	70 x 50	45 x 35	31 x 24
170	118 x 83	85 x 60	53 x 38	39 x 29
200	138 x 92	100 x 70	60 x 50	46 x 34
300	201 x 140	145 x 103	90 x 65	70 x 53
400	265 x 189	186 x 132	121 x 82	94 x 71
500	330 x 232	236 x 167	150 x 110	118 x 89
600	385 x 270	282 x 232	185 x 130	143 x 107

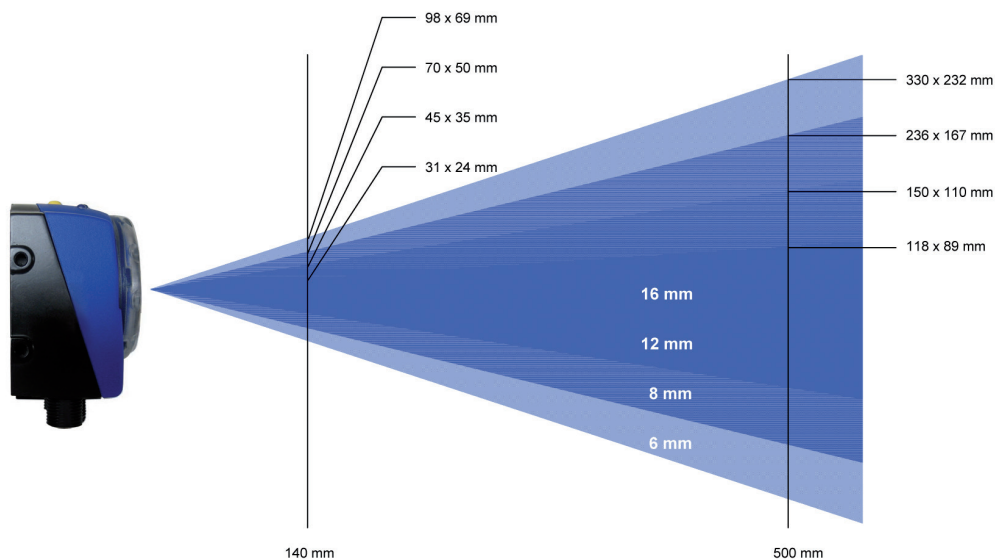

SOFTWARE PC



STEP 1: IMAGE SETUP

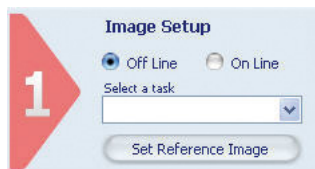

The first step consists in connecting the sensor and configuring the image quality parameters. When the desired results are obtained, the user can memorise the image that will be used as a template during sensor functioning.

STEP 2: TEACH



The second step establishes the acceptance criteria to distinguish objects from wastes. One or more controls can be selected according to the task to carry-out.

STEP 3: RUN

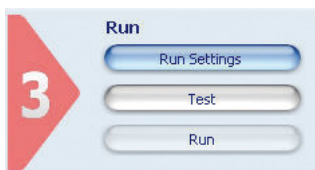

The third step configures the sensor digital outputs, simulates sensor functioning on the PC to verify the controls chosen and activates the operating phase on the sensor using the PC only to control the diagnostics.

MAXIMUM SIMPLICITY

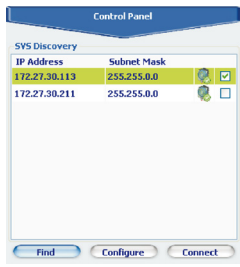

Discovery
The Discovery function finds all the sensors connected to the network.

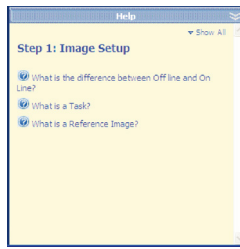

Help
A Help is available for each step, supplying useful suggestions on the options available.

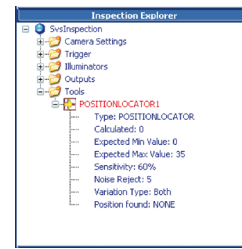

Inspection explorer
All the parameters connected to the inspection are grouped together and can be easily reached by the user.

Statistics

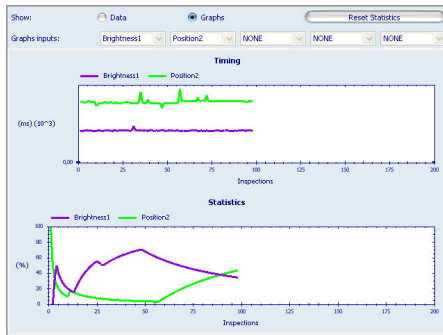

Operator	Execution Time	Total PASSED	Total FAILED	Executed
Image acquisition time	16,42 ms			
Brightness1	0,11 ms	215 (100%)	0 (0%)	215
Contrast3	0,83 ms	215 (100%)	0 (0%)	215
Position4	0,79 ms	0 (0%)	215 (100%)	215
Output delay time:	0,00 ms			
Output duration time:	0,00 ms			
Total execution time:	18,16 ms	0 (0%)	215 (100%)	215
Insp. per second:				55,06 Inspe...

The statistics panel displays all the information about inspection results and execution time. Data can be shown also in a graph.

Image saving

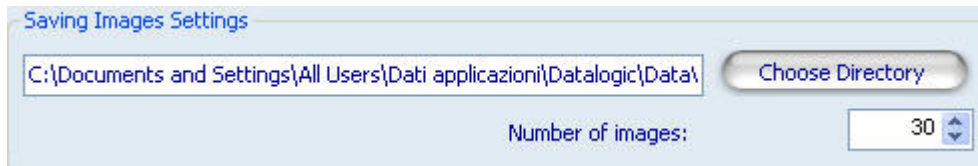

The image saving panel allows to set a folder where the acquired pictures are stored. An image saving condition can be also specified through a dedicated panel.

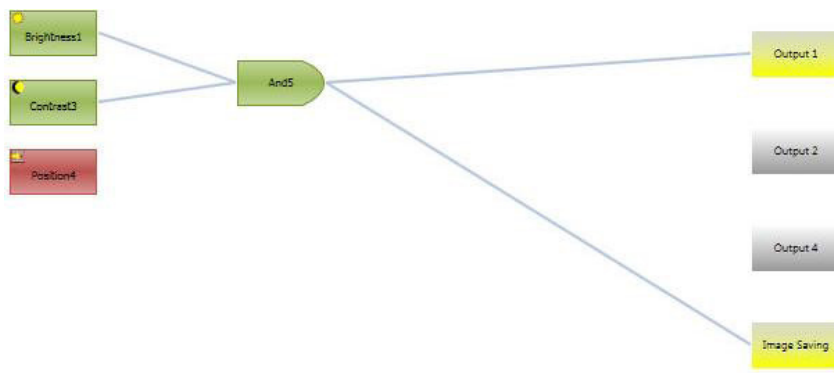

EXCELLENT FLEXIBILITY

Inspection selection

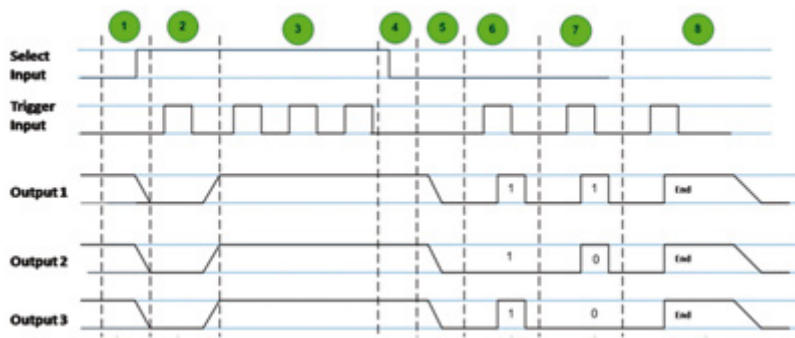

Each inspection is composed of a template and parameters. The user can store up to 20 different inspections on the sensor memory in order to manage different items on the same production line.

The different inspections can be recalled in several different ways:

- (1) using digital pulses on OBJ and AOR models
- (2) through an Ethernet command on AOR, ID and PRO models
- (3) through a Serial command on ID and PRO models







VSM COMPATIBILITY

All DataVS2 models (i.e. OBJ, AOR, ID and PRO) are compatible with VSM, the monitoring device that allows to display elaborated images together with inspection results. The unit also offers the possibility to change the running inspection as well as to fine-tune the vision sensor functioning parameters on-the-fly.

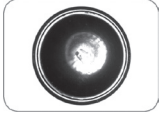
The device integrates a 3.5" LCD color display and 8 push buttons. It features a standard TCP/IP Ethernet interface thus it can be connected either directly to a specific vision sensor or to a Local Area Network (LAN) where more DataVS2 have been previously installed.



CONTROL TABLE

OBJECT RECOGNITION			
Seven different controls able to cover the most varied applications.			
Control	Functioning	Applications	Image
Pattern Match	Searches a sample inside a specific area	<ul style="list-style-type: none"> • Packaging: logo check • Assembling: product orientation • Post automation: stamp check 	
Contour Match	Shape control	<ul style="list-style-type: none"> • Metal working: integrity control • Food: coffee waffle shape control 	
Position	Check of object border position	<ul style="list-style-type: none"> • Bottling: liquid level control • Food: label position control 	
Width	Measures object width	<ul style="list-style-type: none"> • Assembling: plastic part control • Wood industry: branch thickness measurement 	
Counting	Counts the objects along a line	<ul style="list-style-type: none"> • Electronics: component counting • Pharmaceutical: blister stack counting 	
Contrast	Contrast calculation	<ul style="list-style-type: none"> • Food: date and lot presence control • Metal working: laser marking control 	
Brightness	Brightness calculation	<ul style="list-style-type: none"> • Bottling: cap presence control • Packaging: object counting 	

ADVANCED MODELS (AOR)

The Advanced Object Recognition (AOR) models integrate new important functionalities, including:



360° Pattern Match Locator

Object detection independent from rototranslations.



Logical tools

Possibility to combine the results of the single tools through boolean operator (AND, OR, NOT, etc.)

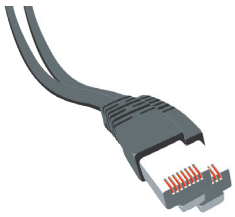

Advanced Ethernet

Current inspection results available also on Ethernet communication.





Speed-up

High execution speed thanks to the management of reduced resolution and TURBO mode.

360° Pattern match

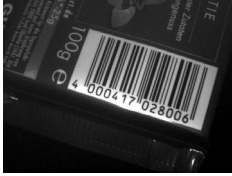
IDENTIFICATION MODELS (ID)

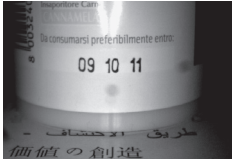

CONTROL	FUNCTIONING	IMAGE
Barcode reader	<p>Decode: read and decode one (or more) barcode in the Region Of Interest.</p> <p>String match: read and decode one (or more) barcode and compare it with a set of reference strings.</p> <p>Counter: count the number of barcodes in the Region Of Interest.</p>	
Datamatrix reader	<p>Decode: read and decode one (or more) datamatrix in the Region Of Interest.</p> <p>String match: read and decode one (or more) datamatrix and compare it with a set of reference strings.</p> <p>Counter: count the number of datamatrix in the Region Of Interest.</p>	
QR Code reader	<p>Decode: read and decode one (or more) QR Code in the Region Of Interest.</p> <p>String match: read and decode one (or more) QR Code and compare it with a set of reference strings.</p> <p>Counter: count the number of QR Code in the Region Of Interest.</p>	
ocv	<p>Verify the readability of printed characters.</p>	

Symbologies

	Codabar		PDF417
	Code 39		Pharmacode
	Code 128		Postnet
	EAN-8 EAN-13 EAN-128		IMB
	Interleaved 2 of 5		ECC200
	UPC-A		QR
	UPC-E		Micro QR

PROFESSIONAL MODELS (PRO)

The professional model includes in the same software all the functionalities already available on Advanced and Identification versions. Moreover it features 6 new software tools: 4 locators and 2 controls.

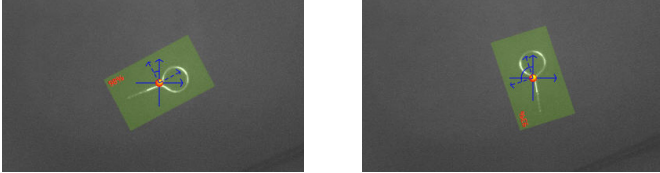
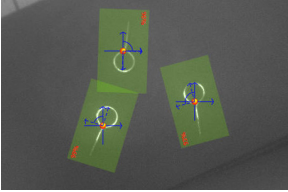
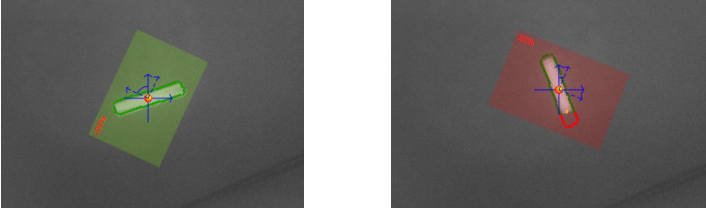
LOCATORS	FUNCTIONING
<p>Barcode</p>	<p>Finds a barcode in the Region Of Interest and re-locates all controls accordingly.</p> 
<p>Datamatrix</p>	<p>Finds a datamatrix code in the Region Of Interest and re-locates all controls accordingly.</p> 
<p>QR Code</p>	<p>Finds a QR Code in the Region Of Interest and re-locates all controls accordingly</p> 
<p>360° Contour Match</p>	<p>Finds a reference template in the Region Of Interest and re-locates controls accordingly.</p> 
CONTROLS	FUNCTIONING
<p>360° Contour Counter</p>	<p>Counts how many times a reference contour is present in the Region Of Interest.</p> 
<p>360° Defect Finder</p>	<p>Detects even smallest defects on a part.</p> 

ACCESSORIES

ST-5066

U-shaped fixing bracket for angle adjustment

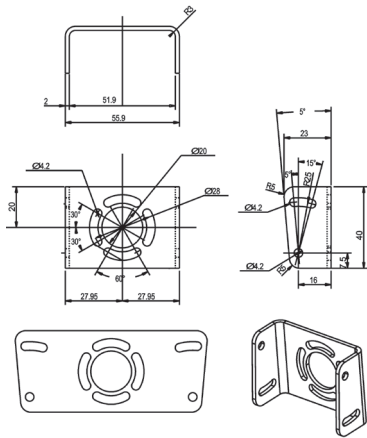

ST-5068

L-shaped fixing bracket for 90° mounting

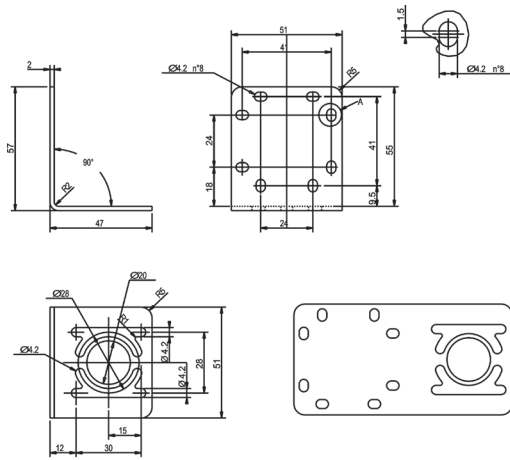

Mounting kit

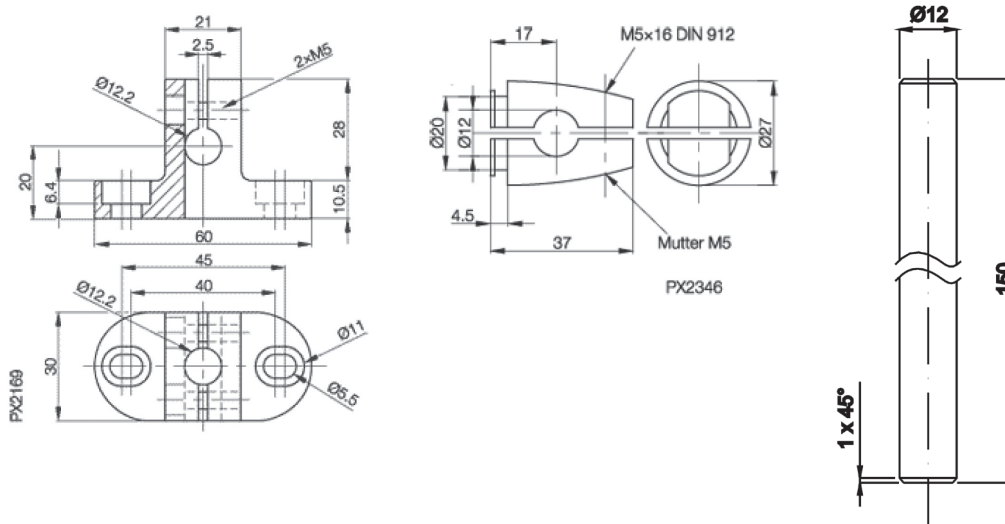

MODEL SELECTION TABLE

MODEL	OPTIC	ILLUMINATOR	I/O	RS232	SOFTWARE	LOGICAL TOOLS	ORDER N°
DataVS2-06-DE-OBJ	6mm	Red	4 outputs - 2 inputs		Basic		959951050
DataVS2-08-DE-OBJ	8mm	Red	4 outputs - 2 inputs		Basic		959951060
DataVS2-12-DE-OBJ	12mm	Red	4 outputs - 2 inputs		Basic		959951070
DataVS2-16-DE-OBJ	16mm	Red	4 outputs - 2 inputs		Basic		959951030
DataVS2-06-DE-AOR	6mm	Red	4 outputs - 2 inputs		Advanced	•	959951000
DataVS2-08-DE-AOR	8mm	Red	4 outputs - 2 inputs		Advanced	•	959951010
DataVS2-12-DE-AOR	12mm	Red	4 outputs - 2 inputs		Advanced	•	959951020
DataVS2-16-DE-AOR	16mm	Red	4 outputs - 2 inputs		Advanced	•	959951040
DataVS2-06-RE-ID	6mm	Red	3 outputs - 1 input	•	Identification	•	959951130
DataVS2-08-RE-ID	8mm	Red	3 outputs - 1 input	•	Identification	•	959951140
DataVS2-12-RE-ID	12mm	Red	3 outputs - 1 input	•	Identification	•	959951120
DataVS2-16-RE-ID	16mm	Red	3 outputs - 1 input	•	Identification	•	959951190
DataVS2-06-RE-PRO	6mm	Red	3 outputs - 1 input	•	Professional	•	959951220
DataVS2-08-RE-PRO	8mm	Red	3 outputs - 1 input	•	Professional	•	959951230
DataVS2-12-RE-PRO	12mm	Red	3 outputs - 1 input	•	Professional	•	959951240
DataVS2-16-RE-PRO	16mm	Red	3 outputs - 1 input	•	Professional	•	959951250
DataVS2-06-DE-AOR-I	6mm	Infrared	4 outputs - 2 inputs		Advanced	•	959951300
DataVS2-08-DE-AOR-I	8mm	Infrared	4 outputs - 2 inputs		Advanced	•	959951310
DataVS2-12-DE-AOR-I	12mm	Infrared	4 outputs - 2 inputs		Advanced	•	959951320
DataVS2-16-DE-AOR-I	16mm	Infrared	4 outputs - 2 inputs		Advanced	•	959951330
DataVS2-06-RE-PRO-I	6mm	Infrared	3 outputs - 1 input	•	Professional	•	959951260
DataVS2-08-RE-PRO-I	8mm	Infrared	3 outputs - 1 input	•	Professional	•	959951270
DataVS2-12-RE-PRO-I	12mm	Infrared	3 outputs - 1 input	•	Professional	•	959951280
DataVS2-16-RE-PRO-I	16mm	Infrared	3 outputs - 1 input	•	Professional	•	959951290

ACCESSORY SELECTION AND ORDER INFORMATION

MODEL	DESCRIPTION	ORDER N°
CV-A1-36-B-03	M12 8-pin shielded cable 3m	95A255430
CV-A1-36-B-05	M12 8-pin shielded cable 5m	95A255440
CV-A1-36-B-10	M12 8-pin shielded cable 10m	95A255450
DATAVS-ST-5068	L-shaped fixing bracket for 90° mounting	95A901320
DATAVS-ST-5066	U-shaped fixing bracket for angle adjustment	95A901330
DATAVS-CV-RJ45C-03	3 m crossed Ethernet cable	95A901340
DATAVS-CV-RJ45D-03	3 m direct Ethernet cable	95A901350
DATAVS-MK-01	Mounting kit	95A901380