

SC5000 Industrial Controller



SC5000 is a high performance industrial controller for omnidirectional and multi-side reading tunnels.

At a glance it's a compact box that consists of a front panel with a multiline display, visual indicators, buttons and network connectors, over a body with further connectivity options.

The front panel hides underneath the mother board, a removable compact flash for parameters system backup and controller replacement, and the field bus board.

SC5000 enables easy installation of complex tunnels with the ability to integrate laser devices, imagers and dimensioners. Installation and setup are pretty smooth processes thanks to enhanced internal connectivity for device synchronization EBC. Specialized connectors helps to avoid any human mistake about cabling the system and e-GENIUS, the web-based user interface, enables users to manage the configuration by all the popular web-browsers and OS. The controller provides all the needed tools for a quick maintenance of a reading tunnel, monitoring performance and system health in real-time.

SC5000 architecture is fully redundant to avoid single point of failure, this scenario usually consists of two SC5000 connected in a closed ring along with more than one laser device.

HIGHLIGHTS

- Industrial controller for multi-side reading stations
- e-GENIUS™ web-based user interface
- Display and 5-key keypad for diagnostics and statistics
- Rugged industrial housing
- Ultralight and compact design
- Built-in Ethernet, Ethernet/IP and native Profibus and Profinet models
- Enables management of systems redundancy and fast scanner replacement in cases of failure
- Ethernet Bus Connections (EBC) for high speed data transmission and real time synchronization

APPLICATION

- Sorting for Transportation & Logistics (Express Couriers, Postal applications)
- Sorting for Distribution (large Logistic/Distribution Centers)
- Sorting for Baggage Handling Systems

ADVANTAGES

- Increased overall product reliability and easy replacement by means of Compact-Flash memory
 - Easy and simple configuration thanks to Datalogic e-GENIUS, web-based user interface
 - Compatible with DS8110 and DX8210 devices, DM3610 dimensioners and hybrid integration with AV7000/NVS9000
- No single point of failure thanks to the redundant architecture (double controller, tachometer, photo-eye and closed EBC loop)

**In-Position
Technologies**

www.iptech1.com | (877) 478-3241 | help@iptech1.com

TECHNICAL DATA

ELECTRICAL FEATURES		
Supply Voltage	10 to 30 Vdc (typ. 24 Vdc)	
Power Consumption	0.5 A Max.	
Communication Interfaces		
Serial Main (isolated)		
- RS232	1200 to 115200 bits/s	
- RS422 full-duplex	1200 to 115200 bits/s	
Serial Aux		
- RS232	1200 to 115200 bits/s	
Ethernet (x2) TCP/IP	100 Mbit/s	
EBC Internal Network	100 Mbit/s	
Fieldbus		
- Profibus (only SC5000-1100 model)	PROFIBUS DP application protocol; up to 12 Mb/s	
- Profinet (only SC5000-1200 model)	PROFINET-IO application protocol; 100 Mb/s	
- All models	Embedded EtherNet/IP; 100 Mb/s	
Inputs	3 polarity insensitive optocoupled inputs: Trigger, Encoder/Tachometer, IN3,	
Outputs	3 optocoupled outputs	
Input/Output	1 configurable Input/Output (PNP or NPN polarity insensitive optocoupled input, or optocoupled output)	
USER INTERFACE		
LCD Display	4 lines by 20 characters LCD	
Keypad	5 keys	
LED Indicators	POWER	STATUS
	TRIG	EBC
	SW-TRIG	OUT1
	ENC	OUT2
	IN3	OUT3
	IN4	OUT4
SOFTWARE FEATURES		
Configuration Modes	e-Genius	
Parameter Storage	Non-volatile extractable SD-card	
ENVIRONMENTAL FEATURES		
Operating Temperature	0° to +50 °C (+32° to +122 °F)	
Storage Temperature	-20° to +70 °C (-4° to +158 °F)	
Humidity	90% non condensing	
Vibration Resistance EN 60068-2-6	14 mm @ 2 to 10 Hz; 1.5 mm @ 13 to 55 Hz; 2 g @ 70-500 Hz; 2 hours on each axis	
Shock Resistance EN 60068-2-27	30 g; 11 ms; 3 shocks on each axis	
Protection Class EN 60529	IP65*	
PHYSICAL FEATURES		
Mechanical Dimensions	192 x 157 x 74 mm (7.57 x 6.18 x 2.91 in)	
Weight	1.5 kg (3.31 lb)	

* Sealed connectors required

MECHANICAL DRAWINGS

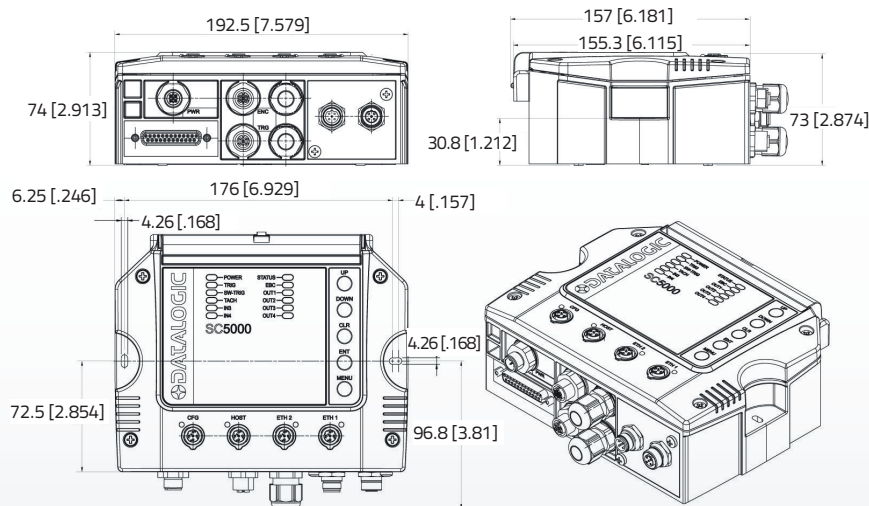

MODELS

DESCRIPTION	PART NUMBER
SC5000-1000 CONTROLLER	935750001
SC5000-1100 CONTROLLER PROFIBUS INTERFACE	935750002
SC5000-1200 CONTROLLER PROFINET INTERFACE	935750003

Rev. 02, 11/2014



The company endeavours to continuously improve and renew its products; for this reason the technical data and contents of this catalogue may undergo variations without prior notice. For correct installation and use, the company can guarantee only the data indicated in the instruction manual supplied with the products. Product and Company names and logos referenced may be either trademarks or registered trademarks of their respective companies. We reserve the right to make modifications and improvements.